

231 SERIES VPR



Flat Valve which avoids fluid leakages during the connection and disconnection.

• Materials

Carbon Steel *EN -10277-3 / AISI 316L*

Seals: **NBR. Viton or EPDM**

Back-up-ring: **PTFE**

Balls: *AISI 1010/1015*

Springs: *Carbon Steel DIN 17233/84(B)*

• **Applications:** Designed for Oil hydraulic Applications according to European Directive 97.23.EC

• Equivalence

Stucchi VEP

• Working temperature (Seals)

	NBR	Viton	EPDM
+	+100°C	+200°C	+150°C
-	-30°C	-10°C	-40°C

• **Sectors:** Industrial, Building Machinery



MODEL STRUCTURE

Example:

231.12313 AD

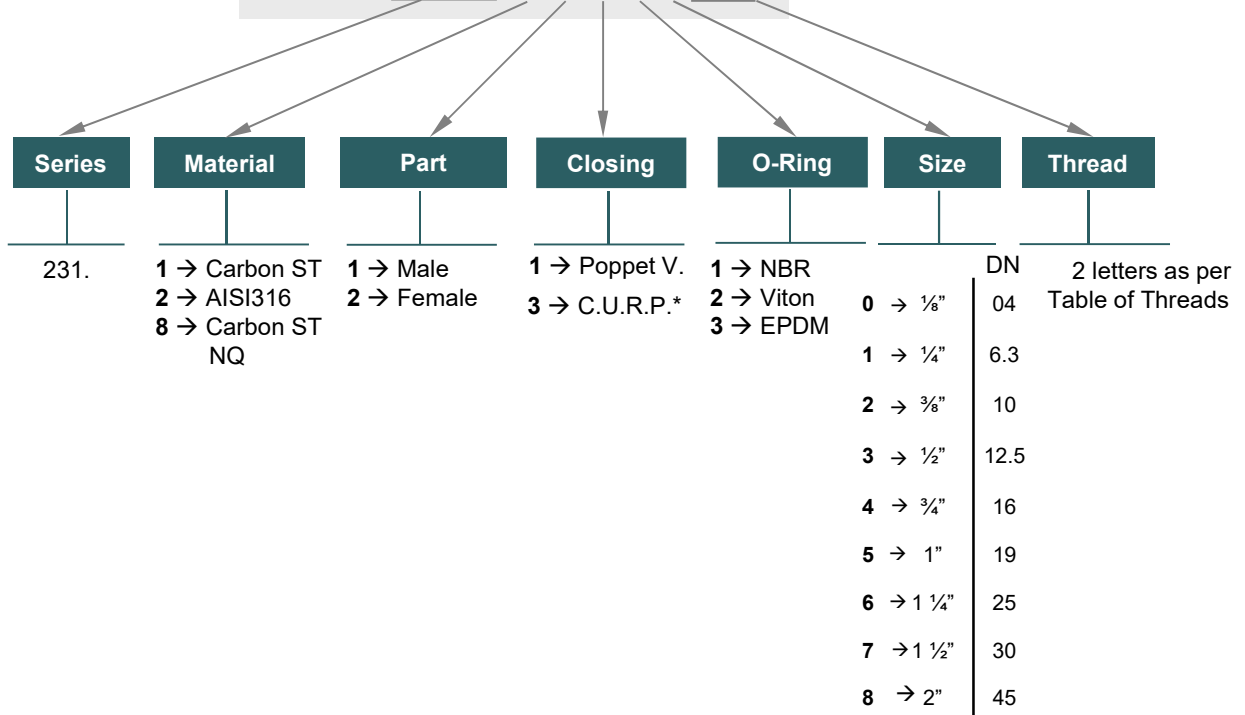

* C.U.R.P. IS AVAILABLE IN MALE PART ONLY

231-1



231 SERIES VPR



MALE

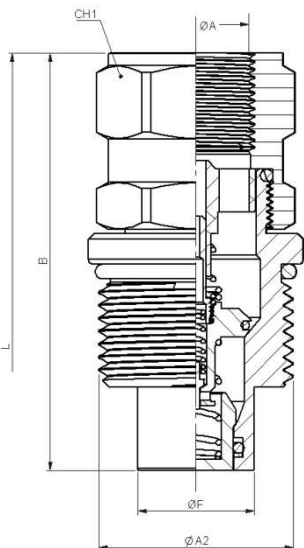

DN	CH1	B	ØA	ØA2	ØF	L
04	19	70	1/8" BSP	M20x2	11,65	90
6.3	22	75	1/4" BSP	M30x2	12,20	110
10	30	73	3/8" BSP	M33x2	19,80	129
12.5	36	85,25	1/2" BSP	M40x3	24,50	155
16	41	97	3/4" BSP	M45x3	27,05	165
19	41	110	1" BSP	M50x3	30,00	188
25	55	133	1 1/4" BSP	M58x3	36,00	230
30	65	135	1 1/2" BSP	M80x4	57,00	255
45	90	220	2" BSP	M130x6	72,95	385

STANDARD MODELS

DN	ØA	MACHO	HEMBRA	
04	1/8" BSP	231.11110AA	231.12110AA	600Bar
		231.11110BA	231.12110BA	
6.3	1/4" BSP	231.11111AB	231.12111AB	600Bar
		231.11111BB	231.12111BB	
	3/8" BSP	231.11312AC	231.12112AC	
		231.11312BC	231.12112BC	
10	1/2" BSP	231.11312AD	231.12112AD	550Bar
		231.11312BD	231.12112BD	
	3/4" NPTF	231.11312GF	231.12112GF	
		231.11312GH	231.12112GH	
12.5	1/2" BSP	231.11313AD	231.12113AD	550Bar
		231.11313BD	231.12113BD	
	3/4" BSP	231.11313AE	231.12113AE	
		231.11313BE	231.12113BE	
16	3/4" NPTF	231.11313GH	231.12113GH	550Bar
		231.11313GK	231.12113GK	
	1 1/16" 12ORB	231.11314AE	231.12114AE	
		231.11314BE	231.12114BE	
19	1 1/16" -12ORB	231.11314GK	231.12114GK	500Bar
		231.11315AF	231.12115AF	
	1" BSP	231.11315BF	231.12115BF	
		231.11315GO	231.12115GO	
25	1 1/4" BSP	231.11316AG	231.12116AG	470Bar
		231.11316BG	231.12116BG	
	1 1/2" BSP	231.11317AH	231.12117AH	
		231.11317BH	231.12117BH	
45	2" BSP	231.11318AI	231.12118AI	350Bar

FEMALE

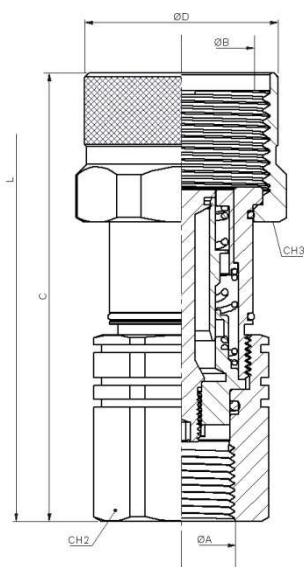

DN	C	CH2	CH3	ØA	ØB	ØD	L
04	50	17	30	1/8" BSP	M20x2	29,5	90
6.3	55	27	36	1/4" BSP	M30x2	26,5	110
10	96	30	38	3/8" BSP	M33x2	37,50	129
12.5	109	41	46	1/2" BSP	M40x3	45,50	155
16	116	41	50	3/4" BSP	M45x3	49,75	165
19	133	46	55	1" BSP	M50x3	54,50	188
25	159	55	65	1 1/4" BSP	M58x3	64	230
30	160	65	85	1 1/2" BSP	M80x4	84	255
45	225	90	-	2" BSP	M130x6	149	385

231 SERIES

VPR

DIN2353



STANDARD MODELS (MALE)

DN	ØA	ØT	REF.		CH1	B	ØF	E	L
6.3	M12x1,5	6L	231.11111JB	600Bar	22	55	16,2	12	106,2
	M14x1,5	8L	231.11111JC			54		11	104,2
	3/8" BSP M.	*	231.11312AN			62,5		12	124,4
10	M14x1,5	8L	231.11312JC	550Bar	30	61,5	19,79	11	122,2
	M16x1,5	10L	231.11312JD			62,5		12	124,4
	M16x1,5	8S	231.11312KD			61,5		11	122,2
	M18x1,5	10S	231.11312KE			62,5		12	124,4
	M20x1,5	12S	231.11312KF			73		11	134,9
	M14x1,5	8L	231.11313JC			73		11	134,9
	M16x1,5	10L	231.11313JD			73		11	134,9
12.5	M18x1,5	12L	231.11313JE	550Bar	36	74	24,58	12	136,9
	M22x1,5	15L	231.11313JG			74		12	139,5
	M26x1,5	18L	231.11313JI			74		12	139,5
	M18x1,5	10S	231.11313KE			80		18	151,5
	M20x1,5	12S	231.11313KF			80		18	151,5
	M22x1,5	14S	231.11313KG			82		12	152,2
	M24x1,5	16S	231.11313KH			88		18	164,2
16	M18x1,5	12I	231.11314JE	550Bar	41	80	27,08	18	151,5
	M22x1,5	15L	231.11314JG			74		12	139,5
	M26x1,5	18L	231.11314JI			74		12	139,5
	M30x2	22L	231.11314JJ			80		18	151,5
	M22x1,5	14S	231.11314KG			82		12	152,2
	M24x1,5	16S	231.11314KH			88		18	164,2
	M30x2	20S	231.11314KJ			81		16	151,2
19	M26x1,5	18L	231.11315JI	500Bar	41	86	30	18	163,2
	M30x2	22L	231.11315JJ			81		16	151,2
	M36x2	28L	231.11315JK			86		18	163,2
	M45x2	35L	231.11315JM			86		18	163,2
	M30x2	20S	231.11315KJ			81		16	151,2
	M36x2	25S	231.11315KK			86		18	163,2
	M42x2	30S	231.11315KL			81		20	153,2
M52x2	38S	231.11315KN	81	20	153,2				

STANDARD MODELS (FEMALE)

DN	ØA	ØT	REF.		CH2	C	ØD	E	L
6.3	M12x1,5	6L	231.12111JB	600Bar	27	62	27,5	12	106,2
	M14x1,5	8L	231.12111JC			63		11	104,2
	3/8" BSP M.	*	231.12112AN			77,5		12	124,4
10	M14x1,5	8L	231.12112JC	550Bar	30	76,5	33	11	122,2
	M16x1,5	10L	231.12112JD			77,5		12	124,4
	M16x1,5	8S	231.12112KD			76,5		11	122,2
	M18x1,5	10S	231.12112KE			77,5		12	124,4
	M20x1,5	12S	231.12112KF			79,5		11	134,9
	M14x1,5	8L	231.12113JC			79,5		11	134,9
	M16x1,5	10L	231.12113JD			79,5		11	134,9
12.5	M18x1,5	12L	231.12113JE	550Bar	41	80,5	38,5	12	136,9
	M22x1,5	15L	231.12113JG			80,5		12	136,9
	M26x1,5	18L	231.12113JI			80,5		12	136,9
	M18x1,5	10S	231.12113KE			83,1		12	139,5
	M20x1,5	12S	231.12113KF			83,1		12	139,5
	M22x1,5	14S	231.12113KG			89,1		18	151,5
	M24x1,5	16S	231.12113KH			89,1		18	151,5
16	M18x1,5	12I	231.12114JE	550Bar	41	89,1	42	12	139,5
	M22x1,5	15L	231.12114JG			89,1		18	151,5
	M26x1,5	18L	231.12114JI			89,1		18	151,5
	M30x2	22L	231.12114JJ			92		12	152,2
	M22x1,5	14S	231.12114KG			92		12	152,2
	M24x1,5	16S	231.12114KH			98		18	164,2
	M30x2	20S	231.12114KJ			98		18	164,2
19	M26x1,5	18L	231.12115JI	500Bar	46	92	30	16	151,2
	M30x2	22L	231.12115JJ			92		16	151,2
	M36x2	28L	231.12115JK			99		18	163,2
	M45x2	35L	231.12115JM			92		16	151,2
	M30x2	20S	231.12115KJ			99		18	163,2
	M36x2	25S	231.12115KK			96		18	163,2
	M42x2	30S	231.12115KL			96		20	153,2
M52x2	38S	231.12115KN	94	20	153,2				

231-3





231 SERIES VPR



TECHNICAL DATA Carbon Steel and Stainless Steel AISI316

DN	Flow Rate	Min. Burst Pressure (Bar)			Max. Working Pressure			Spillage
		Male	Female	Couple d	Male	Female	Coupled	Max.
04	5 l/m	1500	1300	1500	600	430	600	0,011
6.3	25 l/m	1500	1260	1500	600	420	600	0,012
10	45 l/m	1400	1000	1400	550	330	550	0,040
12.5	90 l/m	1400	1000	1400	550	330	550	0,025
16	150 l/m	1400	1000	1400	550	330	550	0,033
19	200 l/m	1250	1000	1250	500	330	500	0,018
25	350 l/m	1200	800	1200	470	300	470	0,060
30	750 l/m	1100	800	1100	400	270	400	0,200
45	1000 l/m	1100	800	1100	350	270	350	0,350

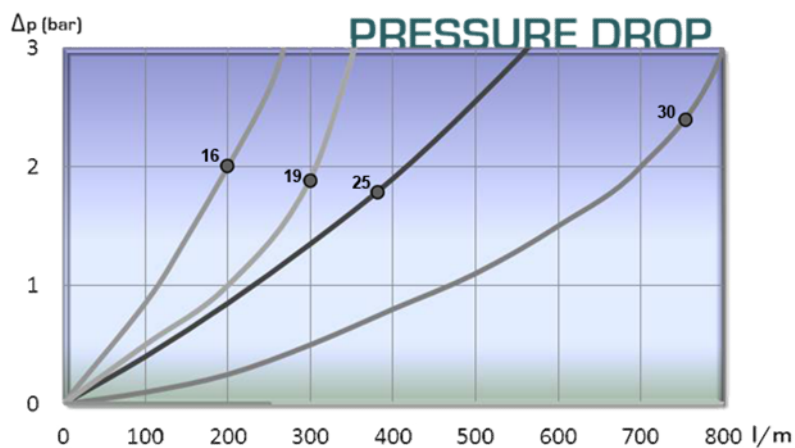
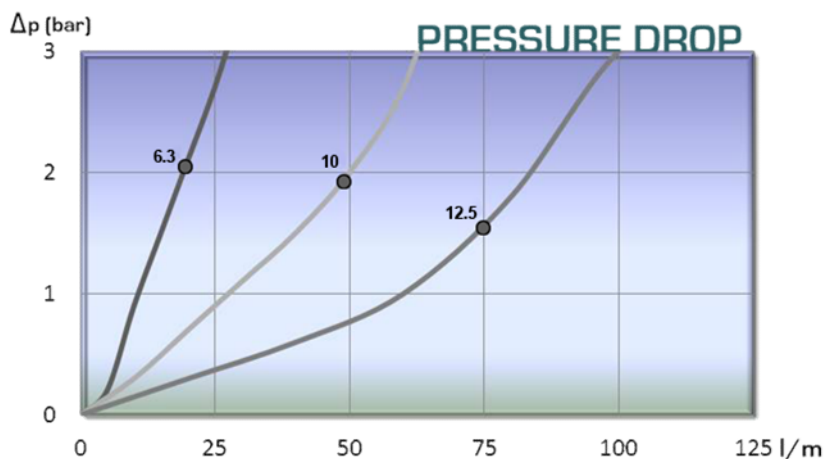



231 SERIES VPR

PLUGS
& CAPS



VPR 231SERIES PLUGS/ CAPS have been designed to protect FEMALE (coupler) or MALE (nipple) parts while they are disconnected.

• **Materials**

Cuerpo: aluminum/ AISI 316L

• **Sectors:** Industrial, Building Machinery.



MODEL STRUCTURE

Example:

231.6301AA

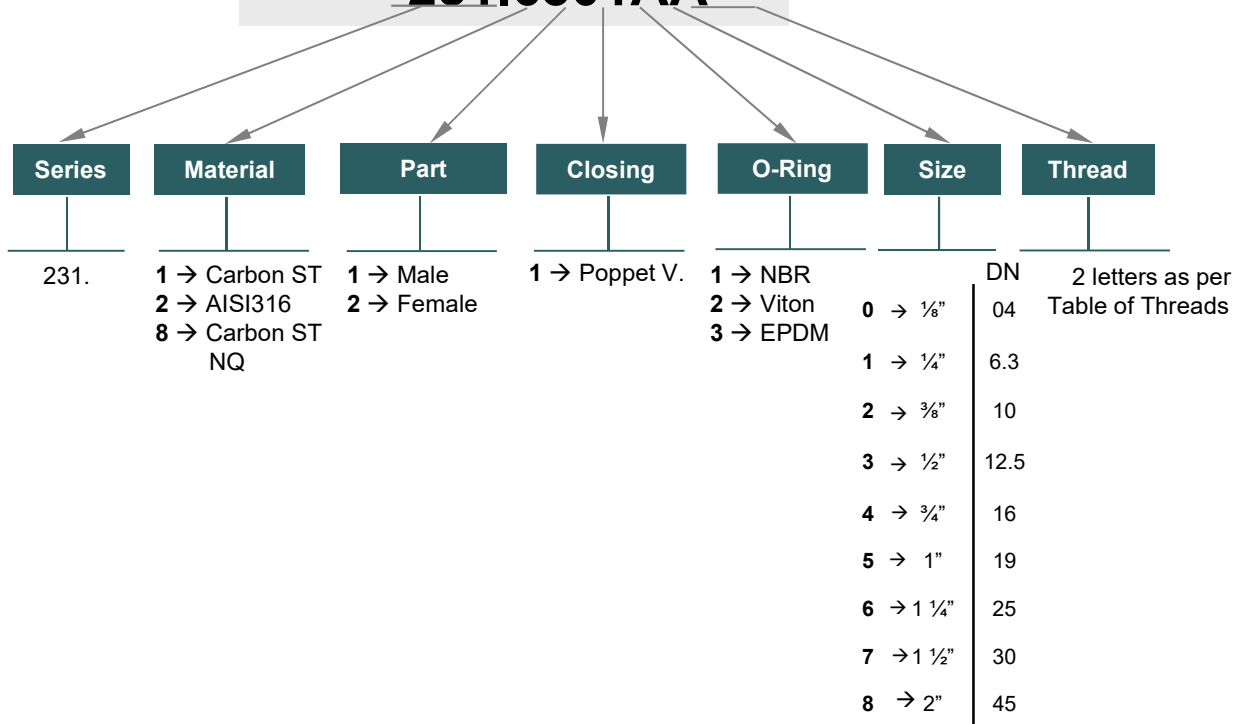



231 SERIES VPR

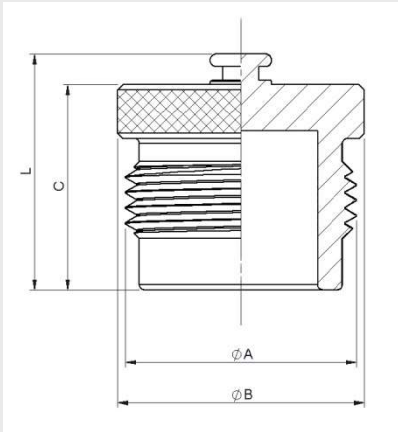

PLUG					
DN	REF.	ØA	ØB	C	L
04	231.6300AA	M20x2	25	28	34
6.3	231.6301AA	M30x2	35	30	36
10	231.6302AA	M33x2	38	32	38
12.5	231.6303AA	M40x3	46	35	41
16	231.6304AA	M45x3	50	39	45
19	231.6305AA	M50x3	55	50	56
25	231.6306AA	M58x3	65	55	61
30	231.6307AA	M80x4	90	65	71
45	231.6308AA	M130x6	145	85	91

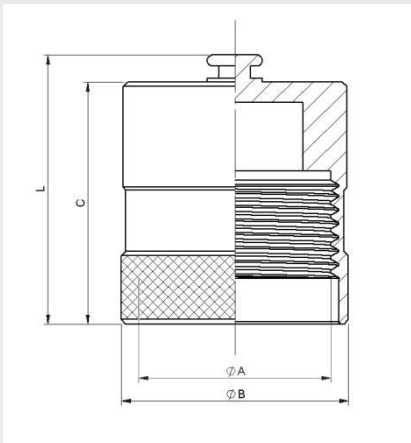

CAP					
DN	REF.	ØA	ØB	C	L
04	231.6400AA	M20x2	25	34	40
6.3	231.6401AA	M30x2	35	45	61
10	231.6402AA	M33x2	38	50	56
12.5	231.6403AA	M40x3	46	52	58
16	231.6404AA	M45x3	50	55	61
19	231.6405AA	M50x3	55	65	71
25	231.6406AA	M58x3	65	65	71
30	231.6407AA	M80x4	90	80	86
45	231.6408AA	M130x6	145	130	136