

# Axial piston fixed pump A17FNO Series 10

**RE 91510**

Issue: 11.2015

Replaces: 06.2012

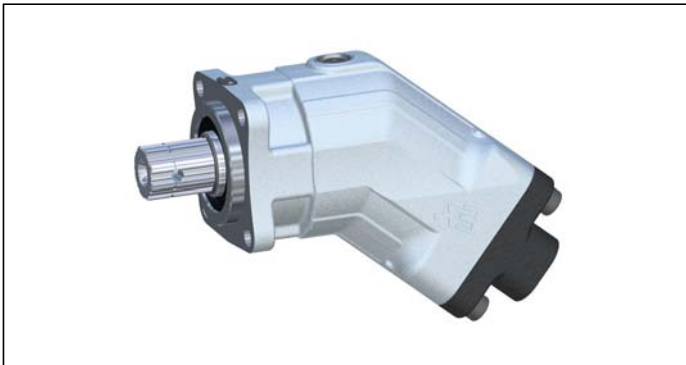

- ▶ Designed for use in commercial vehicles with standard pressure requirements
- ▶ Size 125
- ▶ Nominal pressure/maximum pressure 250/300 bar
- ▶ Bent-axis design
- ▶ Open circuit

**Features**

- ▶ Flange and shaft designed for direct mounting on the power take-off of commercial vehicles
- ▶ Weight-optimized thanks to diecast aluminum housing.
- ▶ No case drain line necessary
- ▶ Reduced noise
- ▶ Straightforward adjustment of direction of drive
- ▶ Excellent suction performance
- ▶ High total efficiency
- ▶ Long service life

**Contents**

Ordering code	2
Hydraulic fluid	3
Operating pressure range	4
Technical Data	5
Direction of rotation	7
Dimensions, size 125	8
Accessories	9
Installation instructions	11
Other related documents	11
Project planning notes	12
Safety instructions	12

## Ordering code

01	02	03	04	05	06	07	08	09	10	11	
<b>A17FN</b>	<b>O</b>		<b>/</b>	<b>10</b>	<b>N</b>	<b>L</b>	<b>W</b>	<b>K0</b>	<b>E8</b>	<b>1</b>	<b>-</b>

### Axial piston unit

01	Bent-axis design, fixed, nominal pressure 250 bar, maximum pressure 300 bar, for commercial vehicles (truck)	<b>A17FN</b>
----	--	--------------

### Operating mode

02	Pump, open circuit	<b>O</b>
----	--------------------	----------

### Sizes (NG)

03	Geometric displacement, see table of values on page 5	<b>125</b>
----	---	------------

### Series

04	Series 1, index 0	<b>10</b>
----	-------------------	-----------

### Configuration of port and fastening threads

05	Metric, port threads with profiled sealing ring according to DIN 3852	<b>N</b>
----	---	----------

### Direction of rotation<sup>1)</sup>

06	Viewed on drive shaft	counter-clockwise	<b>L</b>
----	-----------------------	-------------------	----------

### Sealing material

07	FKM (fluor-caoutchouc) including the 2 shaft seal rings in FKM	<b>W</b>
----	--	----------

### Mounting flange

08	Special flange ISO 7653-1985 (for trucks)	<b>K0</b>
----	---	-----------

### Drive shaft

09	Splined shaft similar to DIN ISO 14 (for trucks)	<b>E8</b>
----	--	-----------

### Service line port

10	Threaded ports <b>A</b> and <b>S</b> at rear	<b>1</b>
----	--	----------

### Standard / special version

11	Standard version	<b>0</b>
	Special version	<b>S</b>

### Note

Note the project planning notes on page 12.

<sup>1)</sup> Changing the direction of rotation see instruction manual 91520-01-B, chapter 6.4.2

## Hydraulic fluid

The A17FNO fixed pump is designed for operation with HLP mineral oil according to DIN 51524.

Application instructions and requirements for hydraulic fluids should be taken from the following data sheets before the start of project planning:

- ▶ 90220: Hydraulic fluids based on mineral oils and related hydrocarbons
- ▶ 90221: Environmentally acceptable hydraulic fluids
- ▶ 90222: Fire-resistant, water-free hydraulic fluids (HFDR/HFDU)

The axial piston unit is not suitable for operation with water-containing HF hydraulic fluid.

### Notes on selection of hydraulic fluid

The hydraulic fluid should be selected such that the operating viscosity in the operating temperature range is within the optimum range ( $v_{opt}$  see selection diagram).

#### Note

At no point of the component may the temperature be higher than 115 °C. The temperature difference specified in the table is to be taken into account when determining the viscosity in the bearing.

Please contact us if the above conditions cannot be met due to extreme operating parameters.

### Viscosity and temperature of hydraulic fluids

	Viscosity	Temperature	Comment
Cold start	$v_{max} \leq 1600 \text{ mm}^2/\text{s}$	$\theta_{St} \geq -25^\circ\text{C}^{1)}$	$t \leq 3 \text{ min}$ , without load ( $p \leq 50 \text{ bar}$ ), $n \leq 1000 \text{ rpm}$
	Permissible temperature difference	$\Delta T \leq 25 \text{ K}$	between axial piston unit and hydraulic fluid in the system
Warm-up phase	$v < 1600 \text{ to } 400 \text{ mm}^2/\text{s}$		at $p \leq 0.7 \times p_{nom}$ , $n \leq 0.5 \times n_{nom}$ and $t \leq 15 \text{ min}$
Continuous operation	$v = 400 \text{ to } 10 \text{ mm}^2/\text{s}$		this corresponds, for VG 46 for example, to a temperature range of +5 °C to +85 °C (see selection diagram)
		$\theta = -25^\circ\text{C} \text{ to } +103^\circ\text{C}$	measured at air bleed port <b>R</b> observe permissible temperature range of the shaft seal ring <sup>1)</sup> ( $\Delta T = \text{approx. } 12 \text{ K}$ between bearing/shaft seal and port <b>R</b> )
	$v_{opt} = 36 \text{ to } 16 \text{ mm}^2/\text{s}$		range of optimum operating viscosity and efficiency
Short-term operation	$v_{min} \geq 7 \text{ mm}^2/\text{s}$		$t < 3 \text{ min}$ , $p < 0.3 \times p_{nom}$

#### ▼ Selection diagram

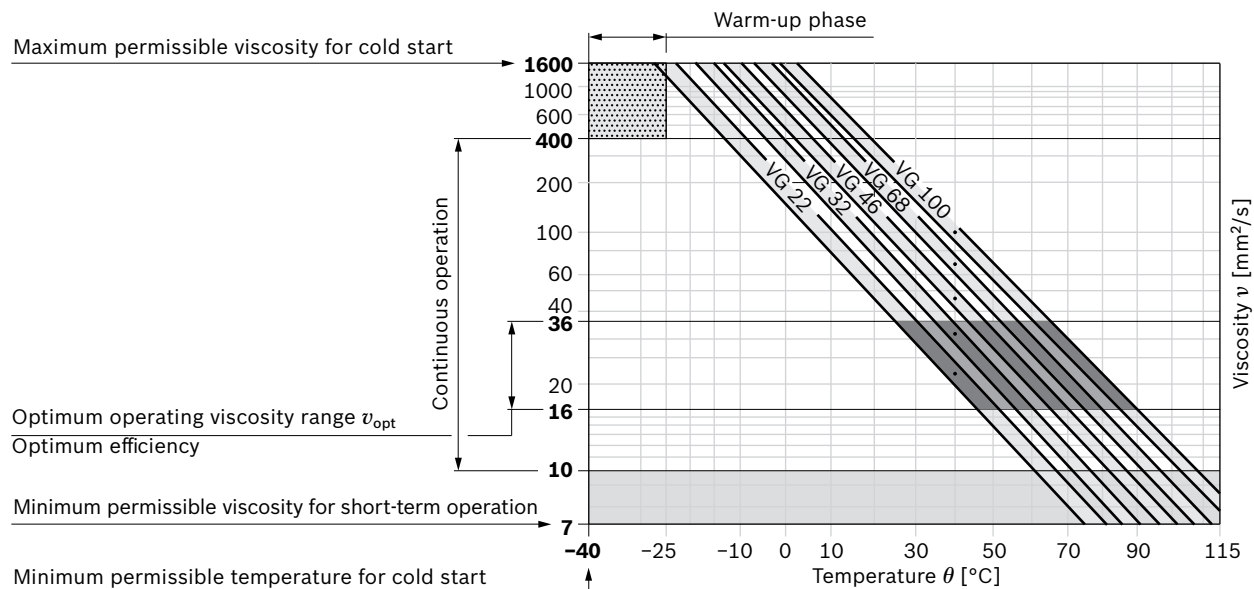

1) The FKM shaft seal is permissible for temperatures of -25 °C to +115 °C, please contact us for temperatures below -25 °C.

### Filtration of the hydraulic fluid

Finer filtration improves the cleanliness level of the hydraulic fluid, which increases the service life of the axial piston unit.

A cleanliness level of at least 20/18/15 is to be maintained according to ISO 4406.

At very high hydraulic fluid temperatures (90 °C to maximum 103 °C, measured at air bleed port **R**), a cleanliness level of at least 19/17/14 according to ISO 4406 is necessary.

### Operating pressure range

Pressure at service line port A (high-pressure side)		Definition
Nominal pressure $p_{nom}$	250 bar absolute	The nominal pressure corresponds to the maximum design pressure.
Maximum pressure $p_{max}$	300 bar absolute	The maximum pressure corresponds to the maximum operating pressure within the single operating period. The sum of the single operating periods must not exceed the total operating period.
Single operating period	5 s	
Total operating period	50 h	
Minimum pressure (high-pressure side)	10 bar absolute	Minimum pressure at the high-pressure side ( <b>A</b> ) which is required in order to prevent damage to the axial piston unit.
Rate of pressure change $R_{A\ max}$	9000 bar/s	Maximum permissible rate of pressure rise and reduction during a pressure change over the entire pressure range.
Pressure at suction port S (inlet)		Definition
Minimum pressure $p_{S\ min}$	0.8 bar absolute	Minimum pressure at suction port <b>S</b> (inlet) which is required in order to prevent damage to the axial piston unit. The minimum pressure is dependent on the speed of the axial piston unit.
Maximum pressure $p_{S\ max}$	2 bar absolute	

#### ▼ Rate of pressure change $R_{A\ max}$

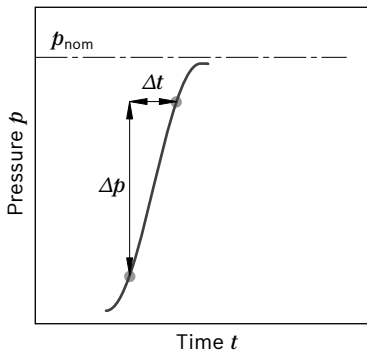

#### ▼ Pressure definition

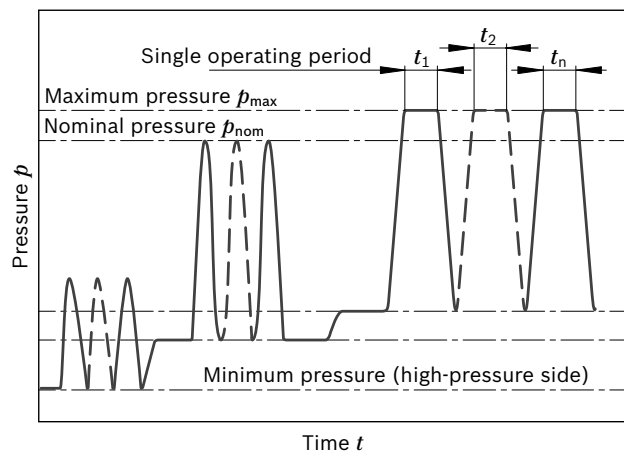

$$\text{Total operating period} = t_1 + t_2 + \dots + t_n$$

#### Note

Operating pressure range valid when using hydraulic fluids based on mineral oils. Values for other hydraulic fluids, please contact us.

## Technical Data

Size		NG	125
Displacement, geometric, per revolution		$V_g$	cm <sup>3</sup> 125
Speed maximum <sup>1)</sup>		$n_{nom}$ <sup>2)</sup>	rpm 1750
		$n_{max}$ <sup>3)</sup>	rpm 2500
Flow	at $n_{nom}$	$q_v$	l/min 219
Power	at $n_{nom}$ and $\Delta p = 350$ bar	$P$	kW 91
Torque	at $\Delta p = 350$ bar	$T$	Nm 497
Rotary stiffness		$c$	kNm/rad 11.9
Moment of inertia for rotary group		$J_{TW}$	kgm <sup>2</sup> 0.0016
Maximum angular acceleration		$\alpha$	rad/s <sup>2</sup> 4500
Case volume		$V$	l 0.83
Mass moment		$T_G$	Nm 20
Mass (approx.)		$m$	kg 15.0

### ▼ Maximum speed (limiting speed)

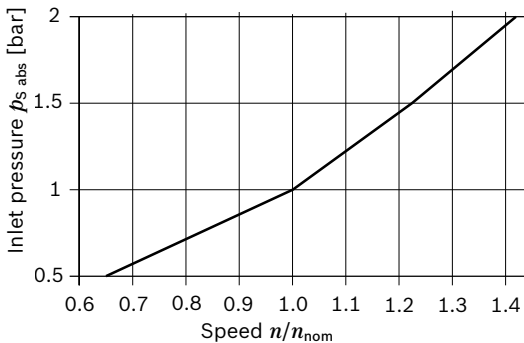

### Determining the operating characteristics

Flow	$q_v = \frac{V_g \times n \times \eta_v}{1000}$	[l/min]
Torque	$T = \frac{V_g \times \Delta p}{20 \times \pi \times \eta_{hm}}$	[Nm]
Power	$P = \frac{2 \pi \times T \times n}{60000} = \frac{q_v \times \Delta p}{600 \times \eta_t}$	[kW]

### Key

$V_g$	Displacement per revolution [cm <sup>3</sup> ]
$\Delta p$	Differential pressure [bar]
$n$	Speed [rpm]
$\eta_v$	Volumetric efficiency
$\eta_{hm}$	Hydraulic-mechanical efficiency
$\eta_t$	Total efficiency ( $\eta_t = \eta_v \times \eta_{hm}$ )

### Note

- ▶ Theoretical values, without efficiency and tolerances; values rounded.
- ▶ Operation above the maximum values or below the minimum values may result in a loss of function, a reduced service life or in the destruction of the axial piston unit. Other permissible limit values, such as speed variation, reduced angular acceleration as a function of the frequency and the permissible angular acceleration at start (lower than the maximum angular acceleration) can be found in data sheet 90261.

1) The values are applicable:

- for the optimum viscosity range from  $\nu_{opt} = 36$  bis  $16$  mm<sup>2</sup>/s
- for hydraulic fluids based on mineral oils.

2) The values apply at absolute pressure  $p_{abs} = 1$  bar at suction port **S**

3) Maximum speed (speed limit) with increased inlet pressure  $p_{abs}$  at suction port **S** (see diagram).

**Permissible axial forces of the drive shaft**

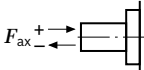
Size		NG	125
Maximum axial force, at standstill or pressure-free operation		+ $F_{ax\ max}$	0
		- $F_{ax\ max}$	77

**Note**

- ▶ The values given are maximum values and do not apply to continuous operation.
- ▶ The permissible axial force in direction  $-F_{ax}$  is to be avoided as the lifetime of the bearing is reduced.
- ▶ Radial forces are not permissible.

## Direction of rotation

The direction of rotation of the axial piston unit is defined by means of a pressure connection screwed into the service line port and can easily be changed.

By changing the pressure connection, the service line port and the suction port are exchanged. As a result, the permissible drive direction is changed. This is necessary when mounting on a power take-off with counter-clockwise rotation, for example. The procedure for conversion of the pressure nipple can be found in the instruction manual (91520-01-B, chapter 6.4.2 “Direction of rotation and change of direction of rotation”).

### Direction of rotation on delivery

On delivery, the pressure connection (1) is pre-assembled in the right-hand service line port of the axial piston unit. The permissible drive direction of the pump looking at the drive shaft: counter-clockwise. The power take-off turns clockwise.

#### Note

The pressure connection is pre-installed upon delivery and must be tightened with the torque stipulated for the appropriate thread size prior to installation (see instruction manual).

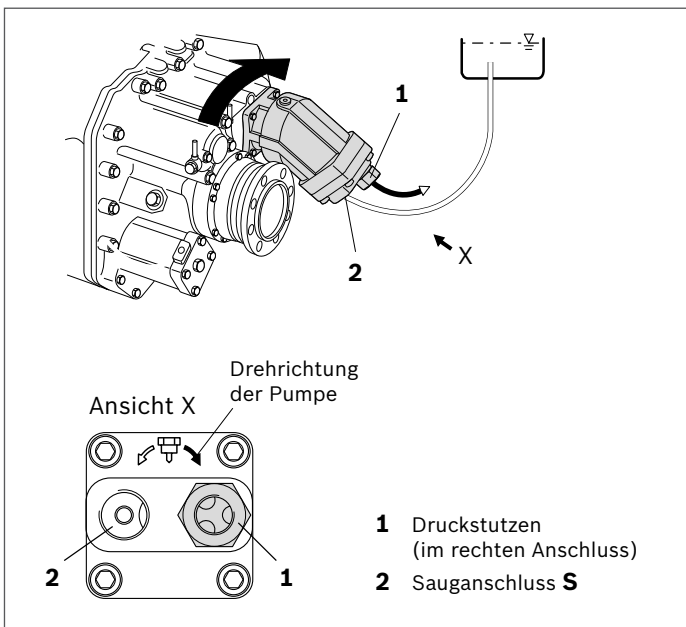





## Accessories

### Suction stud

▼ **Dimensions**

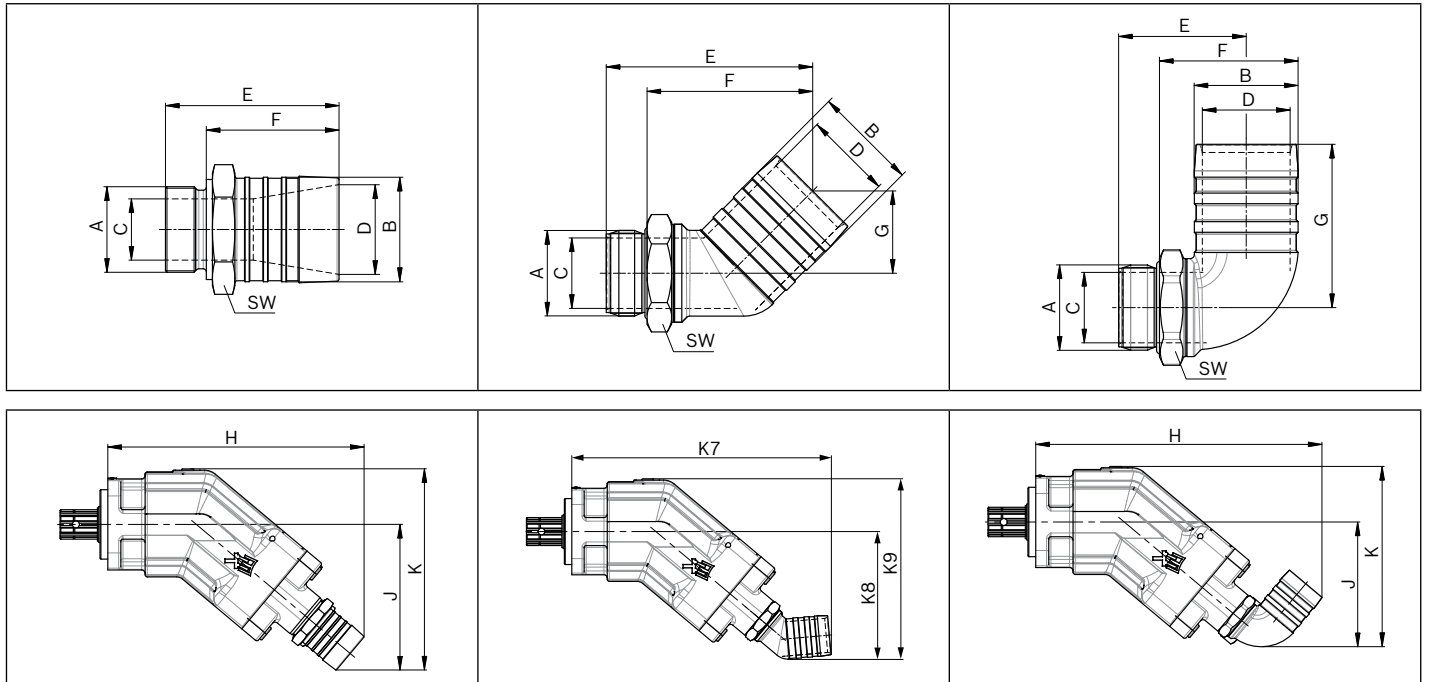

Version	Pump size	Hose nominal width	Material number	Thread K0	K1	K2	K3	K4	K5	K6	K7	K8	K9	SW
Straight	125	2"	R902600252	G1 1/4	51	30	44	85	65	–	306	177	245	55
		2 1/2"	R902601630	G1 1/4	63	31	54	82	64	–	308	180	248	65
45°	125	2"	R909831597	G1 1/4	51	34	43	101	81	40	328	165	234	50
		2 1/2"	R902601631	G1 1/4	63	35	54	100	81	44	331	169	237	50
90°	125	2"	R909831598	G1 1/4	51	35	43	63	43	80	341	153	221	50

The suction stud is not included in the scope of delivery and must be ordered separately.

### Notes on suction line

- ▶ Keep as short and straight as possible, without sharp bend
- ▶ Use a supporting ring for plastic hoses
- ▶ Use two hose clamps to protect the suction hose against air suction
- ▶ Note pressure resistance of suction hose compared to ambient pressure

### Replacing seals

The O-rings used as seals to prevent air from entering the suction line are to be replaced after every removal and new installation in order to guarantee complete sealing.

Material number for O-rings:

- ▶ R909083808: O-ring for suction stud G1 1/4

### Coupling flange

There are special, modified coupling flanges in 4-hole and 6-hole design for the cardan shaft drive.

The coupling flange is not included in the scope of delivery and must be ordered separately.

#### ▼ 4-hole coupling flange, complete – ø 90

Material number: R902060152

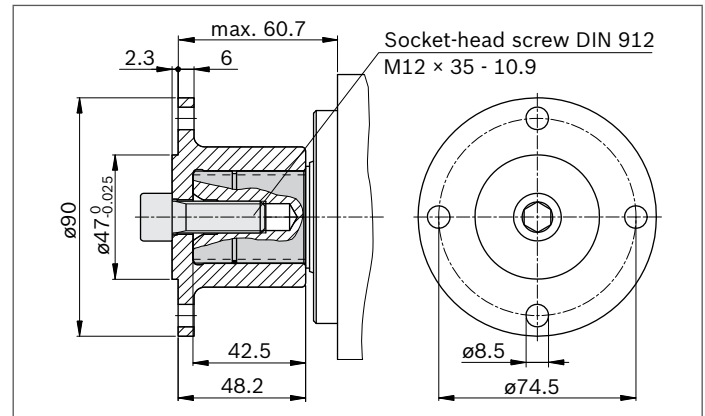

#### ▼ 6-hole coupling flange, complete – ø 100

Material number: R902060153

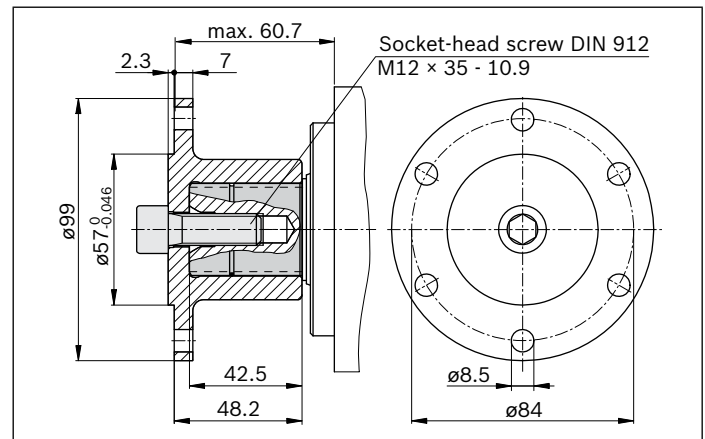

### Note

- ▶ Assembly of the coupling flange is carried out by pulling onto the drive shaft with the aid of the threaded bore in the drive shaft end.
- ▶ The coupling flange must be clamped on the drive shaft using a socket-head screw. In addition, permanent lubrication should be applied between the drive shaft and the coupling flange.
- ▶ The socket-head screw should be secured in a suitable manner (e.g. gluing with Loctite 276) and tightened with a tightening torque of 130 Nm.
- ▶ Sudden axial impact upon the drive shaft will lead to rotary group damage and therefore must be avoided.

## Installation instructions

### General

During commissioning and operation, the axial piston unit must be filled with hydraulic fluid and air bled. This must also be observed following a long standstill as the axial piston unit can empty via the hydraulic lines.

The pump housing is internally connected to the suction chamber. A separate drain line from the housing to the reservoir is not needed.

To achieve favorable noise values, decouple all connecting lines using elastic elements and avoid above-reservoir installation.

In all operating conditions, the suction line must flow into the reservoir below the minimum fluid level. The permissible suction height  $h_S$  results from the overall loss of pressure.

However, it must not be higher than  $h_{S \max} = 800$  mm.

The minimum suction pressure at port **S** must not fall below 0.8 bar absolute during operation and during cold start.

### Installation position

See the following examples **1** to **4**.

Further installation positions are available upon request.

Recommended installation position: **1** and **2**.

### Below-reservoir installation (standard)

Below-reservoir installation means that the axial piston unit is installed outside of the reservoir below the minimum fluid level.

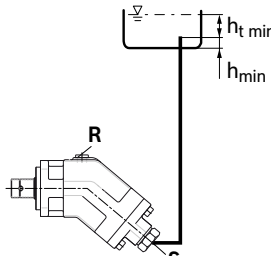
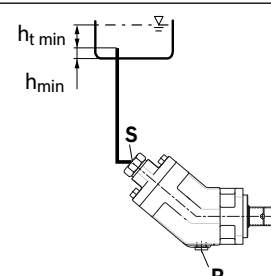
Installation position	Air bleed	Filling
<p><b>1</b></p> 	<b>R</b>	<b>S</b>
<p><b>2</b></p> 	-	<b>S</b>

### Above-reservoir installation

Above-reservoir installation means that the axial piston unit is installed above the minimum fluid level of the reservoir.

Observe the maximum permissible suction height

$h_{S \max} = 800$  mm.

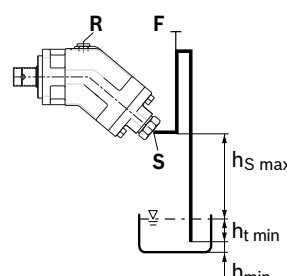
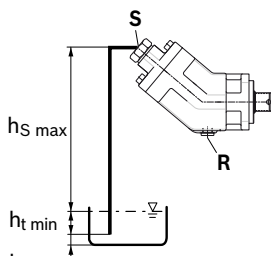
Installation position	Air bleed	Filling
<p><b>3</b></p> 	<b>R</b>	<b>F</b>
<p><b>4</b></p> 	<b>S</b>	<b>S</b>

### Key

**F** Filling/air bleed

**R** Air bleed port

**S** Suction port

$h_{t \min}$  Minimum required immersion depth (200 mm)

$h_{\min}$  Minimum required distance to reservoir bottom (100 mm)

$h_{S \max}$  Maximum permissible suction height (800 mm)

### Note

Port **F** is part of the external piping and must be provided on the customer side to make filling and air bleeding easier.

### Other related documents

Other pumps with special characteristics and dimensions for use in commercial vehicles can be found in the following data sheets:

- ▶ 91520: Fixed pump A17FO, 350/400 bar
- ▶ 92270: Variable pump, A18VO 350/400 bar
- ▶ 92280: Variable pump, A18VLO 350/400 bar

## Project planning notes

- ▶ The A17FNO pump is designed to be used in open circuits.
- ▶ The project planning, installation and commissioning of the axial piston unit requires the involvement of qualified personnel.
- ▶ Before using the axial piston unit, please read the corresponding instruction manual completely and thoroughly. If necessary, these can be requested from Bosch Rexroth.
- ▶ Before finalizing your design, please request a binding installation drawing.
- ▶ The specified data and notes must be observed.
- ▶ Depending on the operating conditions of the axial piston unit (operating pressure, fluid temperature), the characteristic may shift.
- ▶ Preservation: Our axial piston units are supplied as standard with protection to preserve for a maximum of 12 months. If longer preservative protection is required (maximum 24 months), please specify this in plain text when placing your order. The preservation periods apply under optimal storage conditions, details of which can be found in the data sheet 90312 or the instruction manual.
- ▶ Not all variants of the product are approved for use in safety functions according to ISO 13849. Please consult the responsible contact person at Bosch Rexroth if you require reliability parameters (e.g.  $MTTF_d$ ) for functional safety.
- ▶ Be sure to add a pressure relief valve to the hydraulic system.
- ▶ Please note the details regarding the tightening torques of port threads and other threaded joints.
- ▶ Working ports:
  - The ports and fastening threads are designed for the specified maximum pressure. The machine or system manufacturer must ensure that the connecting elements and lines correspond to the specified application conditions (pressure, flow, hydraulic fluid, temperature) with the necessary safety factors.
  - The service line ports and function ports can only be used to accommodate hydraulic lines.

## Safety instructions

- ▶ During and shortly after operation, there is a risk of burns on the axial piston unit and especially on the solenoids. Take appropriate safety measures (e.g. by wearing protective clothing).