



**L**a Oleo Tecnica s.r.l. nasce nel 1976 quale società specializzata nella produzione e distribuzione di flange con attacco conforme alla norma SAE J518. La Oleo Tecnica è certificata TUV CERT in accordo alla norma ISO 9001:2000.

L'impiego delle flange con attacco conforme alla norma SAE J518 è caratteristico degli impianti oleodinamici in vari settori (cantieri navali, macchine movimento terra, betoniere, presse oleodinamiche, ecc...), ed ovunque vi sia passaggio di olio sotto pressione.

La Oleo Tecnica ha esteso la propria gamma di prodotti alle flange CETOP ed inoltre è in grado di fornire qualsiasi flangia speciale a disegno richiesta dal cliente.

Le flange sono ricavate da forgiati normalizzati. Il materiale prevalentemente usato è acciaio (con tenore di carbonio "C" inferiore allo 0,30%).

A richiesta esse vengono fornite zincate o in acciaio inox AISI 316L, con viti metriche o unc, grower ed o-ring di tenuta.

In fase d'ordine una chiara identificazione del prodotto (mediante la sua sigla completa) renderà più semplice la nostra collaborazione.

I dati in questo catalogo non sono impegnativi e la Oleo Tecnica, allo scopo di migliorare la propria produzione, si riserva il diritto di apportare modifiche anche dimensionali in qualsiasi momento e senza alcun preavviso.

Inoltre le informazioni tecniche (es. pressione di esercizio ecc...) si riferiscono alla sola flangia, codolo o raccordo.

A norma di legge sul diritto d'autore e del codice civile, è vietata ogni riproduzione anche parziale delle figure e dei testi di questo catalogo con qualsiasi metodo (elettronico, meccanico, fotocopie, microfilm, registrazioni, ecc...) senza autorizzazione Oleo Tecnica.

**O**leo Tecnica was established in 1976 as a company specialised in the production and distribution of flanges with connection in accordance with SAE J518 standard. Oleo Tecnica has been assessed TUV CERT in accordance with ISO 9001:2000 standard.

*Flanges with connection in accordance with SAE J518 standard are used on oil hydraulic systems in many fields (shipbuilding, earth moving machines, mobile equipments, machine tools, etc...) and where there is passage of oil under pressure.*

*Oleo Tecnica has increased the range of products to CETOP flanges and furthermore we are able to supply any special flanges on customer's drawing.*

*Flanges are made from normalized forgings. Basic material is steel (with carbon "C" content lower than 0,30%).*

*Upon request flanges can be supplied galvanized or in stainless steel AISI 316L and complete of metric or unc screws, washers and o-ring.*

*Please order accordingly to our flange code to make easier our co-operation.*

*The information in the catalogue are not binding and in order to improve production, Oleo Tecnica reserves the right to make any change including size considered necessary at anytime and without previous notice.*

*Furthermore the technical information (ex. the working pressure etc...) are referred to the only flange, adapter or connector.*

*According to the copyright and the civil law, any reproduction (also partial) of figures and texts of this catalogue by means of electronic, mechanical, photocopies, microfilms, recordings or other is forbidden without Oleo Tecnica authorization.*



## INDICE

## INDEX

Rif. / Ref.	Descrizione	Description	Pag. / Page
<b>AFS...G</b>	FLANGE FILETTATE GAS	BSP THREADED FLANGES	5
<b>GFS...G</b>	CONTROFLANGE FILETTATE GAS	BSP THREADED COUNTER-FLANGES	6
<b>DFS...G</b>	DOPPIE FLANGE FILETTATE GAS	BSP THREADED DOUBLE FLANGES	7
<b>AFS...90G</b>	FLANGE A 90° FILETTATE GAS	BSP THREADED 90° FLANGES	8
<b>AFS...90GQ</b>	FLANGE A 90° FILETTATE GAS	BSP THREADED 90° FLANGES	9
<b>AFS...N</b>	FLANGE FILETTATE NPT	NPT THREADED FLANGES	10
<b>GFS...N</b>	CONTROFLANGE FILETTATE NPT	NPT THREADED COUNTER-FLANGES	11
<b>DFS...N</b>	DOPPIE FLANGE FILETTATE NPT	NPT THREADED DOUBLE FLANGES	12
<b>AFS...90N</b>	FLANGE A 90° FILETTATE NPT	NPT THREADED 90° FLANGES	13
<b>AFS...E</b>	FLANGE FILETTATE METRICHE CON ATTACCO DIN 3901-3902	DIN 3901-3902 METRIC THREADED FLANGES	14
<b>AFS...90E</b>	FLANGE 90° FILETTATE METRICHE CON ATTACCO DIN 3901-3902	DIN 3901-3902 METRIC THREADED 90° FLANGES	15
<b>AFS...B</b>	FLANGE A TENUTA CONICA A 60° FILETTATE GAS	60° TAPERED SEAT BSP THREADED FLANGES	16
<b>AFS...J</b>	FLANGE FILETTATE JIC	JIC THREADED FLANGES	17
<b>AFS...90J</b>	FLANGE A 90° FILETTATE JIC	JIC THREADED 90° FLANGES	18
<b>AFS...T</b>	FLANGE FILETTATE "UN" CON FILETTO CILINDRICO CON SEDE O-RING	"UN" THREADED FLANGES WITH O-RING GROOVE PARALLEL THREAD	19
<b>GFS...T</b>	CONTROFLANGE FILETTATE "UN" CON FILETTO CILINDRICO CON SEDE O-RING	"UN" THREADED COUNTER-FLANGES WITH O-RING GROOVE PARALLEL THREAD	20
<b>AFS...90T</b>	FLANGE A 90° FILETTATE "UN" CON FILETTO CILINDRICO CON SEDE O-RING	"UN" THREADED 90° FLANGES WITH O-RING GROOVE PARALLEL THREAD	21
<b>AFS...90B</b>	FLANGE A 90° A TENUTA CONICA A 60° FILETTATE GAS	90° FLANGES WITH 60° TAPERED SEAT AND BSP THREADED	22
<b>AFS...S</b>	FLANGE A SALDARE DI TASCA	WELD IN FLANGES	23
<b>GFS...S</b>	CONTROFLANGE A SALDARE DI TASCA	WELD IN COUNTER-FLANGES	24
<b>AFS...SA</b>	FLANGE A SALDARE DI TASCA TUBO METRICO	METRIC PIPE WELD IN FLANGES	25
<b>GFS...SA</b>	CONTROFLANGE A SALDARE DI TASCA TUBO METRICO	METRIC PIPE WELD IN COUNTER-FLANGES	26
<b>DFS...S</b>	DOPPIE FLANGE A SALDARE DI TASCA	WELD IN DOUBLE FLANGES	27
<b>DFS...F</b>	DOPPIE FLANGE FILETTATE GAS E A SALDARE DI TASCA	BSP THREADED AND WELD IN DOUBLE FLANGES	28
<b>AFS...90S</b>	FLANGE A 90° A SALDARE DI TASCA	WELD IN 90° FLANGES	29
<b>AFS...90SA</b>	FLANGE A 90° A SALDARE DI TASCA TUBO METRICO	METRIC PIPE WELD IN 90° FLANGES	30
<b>GFS...90S</b>	CONTROFLANGE A 90° A SALDARE DI TASCA	WELD IN 90° COUNTER-FLANGES	31
<b>AFS...90SQ</b>	FLANGE A 90° A SALDARE DI TASCA	WELD IN 90° FLANGES	32
<b>AFC...S</b>	FLANGE PIATTE A SALDARE DI TASCA	WELD IN FLAT FLANGES	33
<b>GFC...S</b>	CONTROFLANGE PIATTE A SALDARE DI TASCA	WELD IN FLAT COUNTER-FLANGES	34
<b>PFS...</b>	FLANGE PIATTE A SALDARE DI TASCA	WELD IN FLAT FLANGES	35
<b>PFS...SP</b>	FLANGE PIATTE CON TASCA	POCKET FLAT FLANGES	36
<b>PFS...P</b>	FLANGE PIATTE CON FORO PASSANTE	FLAT FLANGES WITH THROUGH HOLE	36
<b>D...</b>	DISTANZIALE SAE CON FORO LATERALE	SAE DISTANCE PIECE WITH LATERAL HOLE	37
<b>AFS...ST80</b>	FLANGE A SALDARE DI TESTA SCH.80	WELD ON FLANGES SCH.80	38
<b>AFS...ST160</b>	FLANGE A SALDARE DI TESTA SCH.160	WELD ON FLANGES SCH.160	39
<b>AFS...STXXS</b>	FLANGE A SALDARE DI TESTA SCH.XXS	WELD ON FLANGES SCH.XXS	40
<b>GFS...ST80</b>	CONTROFLANGE A SALDARE DI TESTA SCH. 80	WELD ON COUNTER-FLANGES SCH.80	41
<b>GFS...ST160</b>	CONTROFLANGE A SALDARE DI TESTA SCH. 160	WELD ON COUNTER-FLANGES SCH.160	42
<b>GFS...STXXS</b>	CONTROFLANGE A SALDARE DI TESTA SCH. XXS	WELD ON COUNTER- FLANGES SCH.XXS	43
<b>DFS...ST</b>	DOPPIE FLANGE A SALDARE DI TESTA SCH.80, SCH.160, SCH. XXS	WELD ON DOUBLE FLANGES SCH.80, SCH.160, SCH. XXS	44
<b>AFS...SRE</b>	FLANGE A SALDARE DI TESTA TUBO METRICO FORO CILINDRICO	METRIC PIPE CYLINDRIC HOLE WELD ON FLANGES	45
<b>AFS...STRE</b>	FLANGE A SALDARE DI TESTA TUBO METRICO	METRIC PIPE WELD ON FLANGES	46
<b>GFS...SRE</b>	CONTROFLANGE A SALDARE DI TESTA TUBO METRICO FORO CILINDRICO	METRIC PIPE CYLINDRIC HOLE WELD ON COUNTER-FLANGES	47
<b>GFS...STRE</b>	CONTROFLANGE A SALDARE DI TESTA TUBO METRICO	METRIC PIPE WELD ON COUNTER-FLANGES	48



## INDICE

## INDEX

Rif. / Ref.	Descrizione	Description	Pag. / Page
<b>AFS...90ST</b>	FLANGE A 90° A SALDARE DI TESTA	WELD ON 90° FLANGES	49
<b>AFS...90ST SPEC</b>	FLANGE A 90° A SALDARE DI TESTA	WELD ON 90° FLANGES	50
<b>AFC...</b>	FLANGE CIECHE	BLIND FLANGES	51
<b>GFC...</b>	CONTROFLANGE CIECHE	BLIND COUNTER-FLANGES	52
<b>AFS...</b>	SEMIFLANGE TAGLIATE	CUT SPLIT FLANGES	53
<b>AFSI...</b>	SEMIFLANGE INTERE	UNCUT SPLIT FLANGES	54
<b>AFPI...</b>	SEMIFLANGE PIATTE INTERE	UNCUT FLAT SPLIT FLANGES	54
<b>GFSI...</b>	SEMIFLANGE INTERE CON FORI DI FISSAGGIO FILETTATI METRICI	UNCUT SPLIT FLANGES WITH METRIC THREADED FIXING HOLES	55
<b>GFSI...U</b>	SEMIFLANGE INTERE CON FORI DI FISSAGGIO FILETTATI UNC	UNCUT SPLIT FLANGES WITH UNC THREADED FIXING HOLES	56
<b>AFP...</b>	SEMIFLANGE PIATTE TAGLIATE	CUT FLAT SPLIT FLANGES	57
<b>SFS...ST</b>	CODOLI A SALDARE DI TESTA PER TUBO METRICO	WELD ON ADAPTERS FOR METRIC TUBE	58
<b>SFS...STA</b>	CODOLI A SALDARE DI TESTA PER TUBO GAS	WELD ON ADAPTERS FOR BSP TUBE	59
<b>SFS...GC</b>	CODOLI FILETTATI GAS CONICO	BSP TAPERED THREADED ADAPTERS	60
<b>SFCE...</b>	CODOLI FILETTATI METRICI ATTACCO DIN 3901- 3902	DIN 3901 - 3902 METRIC THREADED ADAPTERS	61
<b>SFS...G2OR</b>	CODOLI FILETTATI GAS CILINDRICO DOPPIA SEDE O-RING	BSP CYLINDRICAL THREADED ADAPTERS WITH DOUBLE O-RING SEAT	62
<b>SFS...G2ORG100</b>	CODOLI FILETTATI GAS CILINDRICO DOPPIA SEDE O-R LUNGO	BSP CYLINDRICAL THREADED LONG ADAPTERS WITH DOUBLE O-RING SEAT	63
<b>OVA...</b>	FLANGE OVALI CON FORO PASSANTE	OVAL FLANGES WITH THROUGH HOLE	64
<b>FORO LATERALE</b>	TABELLA INFORMATIVA PER FORO CONTROLLO PRESSIONE	INFORMATIVE TABLE FOR HOLE TO CHECK PRESSURE	65
	<b>TABELLE TECNICHE PER ASSIEMI</b>	<b>TECHNICAL TABLES FOR SPLIT FLANGES</b>	67
	<b>GRUPPI SEMIFLANGE</b>	<b>GROUP ASSEMBLING</b>	
<b>AFS...STM</b>	GRUPPO SEMIFLANGIA TAGLIATA	GROUP CUT SPLIT FLANGE	68
<b>DFS...STM</b>	DOPPIA SEMIFLANGIA TAGLIATA	DOUBLE CUT SPLIT FLANGE	68
<b>AFSI...STM</b>	GRUPPO SEMIFLANGIA INTERA	GROUP UNCUT SPLIT FLANGE	69
<b>DFSI...STM</b>	DOPPIA SEMIFLANGIA INTERA	DOUBLE UNCUT SPLIT FLANGE	69
	<b>TABELLE TECNICHE PER RACCORDI POMPA</b>	<b>TECHNICAL TABLES FOR PUMPS CONNECTORS</b>	71
<b>RP.../RPI...</b>	RACCORDI POMPA TIPO RP/RPI	STRAIGHT CONNECTORS RP/RPI TYPE	72
<b>RPE.../RPS...</b>	RACCORDI POMPA TIPO RPE/RPS	STRAIGHT CONNECTORS RPE/RPS TYPE	73
<b>GF...LK...</b>	RACCORDI DIRITTI FILETTATI METRICI DIN 3901-3902	DIN 3901-3902 METRIC THREADED STRAIGHT CONNECTORS	74
<b>RP90...</b>	RACCORDI POMPA 3 FORI	PUMP ELBOWS WITH 3 FIXING HOLES	75
<b>GF...90M...</b>	RACCORDI A 4 FORI A 90° FILETTATI METRICI DIN 3901 - 3902	DIN 3901 - 3902 METRIC THREADED 90° CONNECTORS WITH 4 FIXING HOLES	76
<b>GF...90...</b>	RACCORDI A 4 FORI A 90° FILETTATI GAS	BSP THREADED 90° CONNECTORS WITH 4 FIXING HOLES	77
	<b>TABELLE TECNICHE PER FLANGE CETOP</b>	<b>TECHNICAL TABLES FOR CETOP FLANGES</b>	79
<b>CET...ST...</b>	FLANGE CETOP	CETOP FLANGES	80
<b>COD...ST...</b>	CODOLI A SALDARE DI TESTA CETOP	WELD ON CETOP ADAPTERS	81
<b>COD...C...</b>	CODOLI CIECHI CETOP	CETOP BLIND ADAPTERS	82
<b>GCET...ST...</b>	GRUPPO FLANGIA CETOP CON CODOLO A SALDARE DI TESTA E SET VITI METRICHE	GROUP OF CETOP FLANGE WITH WELD ON ADAPTER AND METRIC SCREWS SET	83
<b>GCET...C...</b>	GRUPPO FLANGIA CETOP CON CODOLO CIECO E SET VITI METRICHE	GROUP OF CETOP FLANGE WITH BLIND ADAPTER AND METRIC SCREWS SET	84
<b>DCET...ST...</b>	DOPPIE FLANGE CETOP CON CODOLO E CONTROCODOLO A SALDARE DI TESTA E SET VITI METRICHE	CETOP DOUBLE FLANGES WITH WELD ON ADAPTER WITH AND WITHOUT O-RING SEAT AND METRIC SCREWS SET	85
<b>DCET...C...</b>	DOPPIE FLANGE CETOP CON CODOLO CIECO E CONTROCODOLO A SALDARE DI TESTA E SET VITI METRICHE	CETOP DOUBLE FLANGES WITH BLIND ADAPTER AND WELD ON ADAPTER WITHOUT O-RING SEAT AND METRIC SCREWS SET	86
<b>CET...ST90...</b>	FLANGE CETOP A 90°	90° CETOP FLANGE	87



## INDICE

## INDEX

Rif. / Ref.	Descrizione	Description	Pag. / Page
	<b>TABELLE TECNICHE PER PRODOTTI IN ESECUZIONE SU RICHIESTA</b>	<b>TECHNICAL TABLES FOR PRODUCTS ON REQUEST</b>	89
<b>RIF...</b>	ADATTATORE SAE DI RIDUZIONE	SAE REDUCER ADAPTER	90
<b>SFS...D</b>	CODOLI DOPPI	DOUBLE ADAPTERS	91
<b>CET...C</b>	FLANGE CETOP CIECHE	BLIND CETOP FLANGES	92
<b>TBL...</b>	BLOCCHI SAE A "T"	SAE "T" BLOCKS	93
	<b>TABELLE TECNICHE PER PRODOTTI ACCESSORI PER FLANGE SAE</b>	<b>TECHNICAL TABLES RELEVANT TO ACCESSORIES FOR SAE FLANGES</b>	95
<b>CARATTERIST. SAE</b>	TABELLA RIASSUNTIVA CARATTERISTICHE TECNICHE FLANGE SAE	RESUMING TABLE WITH SAE FLANGES TECHNICAL CHARACTERISTICS	96/97
<b>GROWER..</b>	RONDELLE GROWER DIN 7980	SPRINGLOCKWASHERS WITH SQUARE ENDS ACCORDING TO DIN 7980	98
<b>TAB O-RING</b>	DIMENSIONI O-RING SAE DIMENSIONI SEDE O-RING SAE	SAE O-RING DIMENSIONS SAE O-RING SEAT DIMENSIONS	99
<b>TAB SCHED TUBI</b>	TABELLA SPESSORI SCHEDULE TUBI PER CORRISPONDENZA CON QUOTA "B" FLANGE SAE A SALDARE	TABLE FOR PIPES' THICKNESS FOR CROSS REFERENCE WITH "B" DIMENSION OF WELDING SAE FLANGES	100

**FLANGE  
FILETTATE  
GAS**



**BSP  
THREADED  
FLANGES**

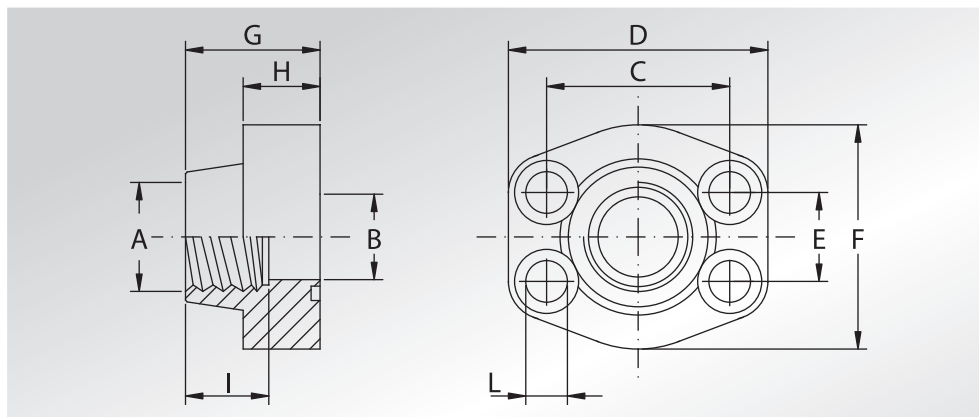

Pressione max di esercizio raccomandata Kg/cm <sup>2</sup>	Grandezza	Tipo	Dimensioni										Viti		Or tipo	Peso Kg
			Dimensions										Screws			
Maximum recommended working pressure Kg/cm <sup>2</sup>	Size	Type	A	B	C	D	E	F	G	H	I	L	Metric	Unc	Or type	Weight Kg

**SERIE 3000**

345	1/2"	AFS080G	1/2" GAS	13	38,10	57	17,48	46	36	16	19	9	M8x30	5/16x1"1/4	4075	0,25
345	1/2"	AFS080G038	3/8" GAS	13	38,10	57	17,48	46	36	16	19	9	M8x30	5/16x1"1/4	4075	0,27
345	3/4"	AFS100G	3/4" GAS	19	47,63	65	22,23	50	36	18	19	11	M10x35	3/8x1"1/2	4100	0,37
345	3/4"	AFS100G012	1/2" GAS	13	47,63	65	22,23	50	36	18	19	11	M10x35	3/8x1"1/2	4100	0,40
345	1"	AFS102G	1" GAS	25	52,37	70	26,19	55	38	18	22	11	M10x35	3/8x1"1/2	4131	0,45
345	1"	AFS102G034	3/4" GAS	19	52,37	70	26,19	55	35	21	19	11	M10x40	3/8x1"1/2	4131	0,51
276	1"1/4	AFS104G	1"1/4 GAS	32	58,72	79	30,18	68	40	21	22	11,5	M10x40	7/16x1"3/4	4150	0,66
276	1"1/4	AFS104GL13	1"1/4 GAS	32	58,72	79	30,18	68	40	21	22	13,5	M12x45	-	4150	0,66
276	1"1/4	AFS104G100	1" GAS	25	58,72	81	30,18	65	42	25	24	11,5	M10x40	7/16x1"3/4	4150	0,80
207	1"1/2	AFS106G	1"1/2 GAS	38	69,85	93	35,71	78	45	25	24	13,5	M12x45	1/2x1"3/4	4187	1,05
207	1"1/2	AFS106G114	1"1/4 GAS	32	69,85	95	35,71	78	45	27	24	13,5	M12x45	1/2x1"3/4	4187	1,17
207	2"	AFS108G	2" GAS	51	77,77	102	42,88	90	45	25	30	13,5	M12x45	1/2x1"3/4	4225	1,17
207	2"	AFS108G112	1"1/2 GAS	38	77,77	102	42,88	90	45	25	26	13,5	M12x45	1/2x1"3/4	4225	1,52
172	2"1/2	AFS110G	2"1/2 GAS	63	88,90	114	50,80	105	50	25	30	13,5	M12x45	1/2x1"3/4	4275	1,59
173	2"1/2	AFS110G200	2" GAS	51	88,90	114	50,80	105	50	25	30	13,5	M12x45	1/2x1"3/4	4275	2,13
138	3"	AFS112G	3" GAS	73	106,38	134	61,93	124	50	27	34	17,5	M16x50	5/8x2"	4337	2,28
138	3"	AFS112G212	2"1/2 GAS	63	106,38	134	61,93	124	50	27	30	17,5	M16x50	5/8x2"	4337	2,56
34	3"1/2	AFS114G	3"1/2 GAS	89	120,65	152	69,85	136	48	27	34	17,5	M16x50	5/8x2"	4387	2,42
34	3"1/2	AFS114G300	3" GAS	73	120,65	152	69,85	136	48	27	34	17,5	M16x50	5/8x2"	4387	3,28
34	4"	AFS116G	4" GAS	99	130,18	162	77,77	146	48	27	34	17,5	M16x50	5/8x2"	4437	2,78
34	4"	AFS116G312	3"1/2 GAS	89	130,18	162	77,77	146	48	27	34	17,5	M16x50	5/8x2"	4437	3,30
34	5"	AFS118G (*)	5" GAS	120	152,40	184	92,08	180	50	28	30	17,5	M16x50	5/8x2"	4537	3,80

**SERIE 6000**

414	1/2"	AFS401G012	1/2" GAS	13	40,49	57	18,24	46	36	16	19	9	M8x30	5/16x1"1/4	4075	0,25
414	1/2"	AFS401G038	3/8" GAS	13	40,49	57	18,24	46	36	16	19	9	M8x30	5/16x1"1/4	4075	0,28
414	3/4"	AFS402G	3/4" GAS	19	50,80	71	23,80	55	35	21	22	11	M10x40	3/8x1"1/2	4100	0,51
414	3/4"	AFS402G012	1/2" GAS	13	50,80	71	23,80	55	35	21	22	11	M10x40	3/8x1"1/2	4100	0,56
414	1"	AFS403G	1" GAS	25	57,15	81	27,76	65	42	25	24	13	M12x45	7/16x1"3/4	4131	0,81
414	1"	AFS403G034	3/4" GAS	19	57,15	81	27,76	65	42	25	24	13	M12x45	7/16x1"3/4	4131	0,84
414	1"1/4	AFS404G	1"1/4 GAS	32	66,68	95	31,75	78	45	27	25	15 *	M14x45	1/2x1"3/4	4150	1,13
414	1"1/4	AFS404G100	1" GAS	25	66,68	95	31,75	78	45	27	25	15 *	M14x45	1/2x1"3/4	4150	1,26
414	1"1/2	AFS405G	1"1/2 GAS	38	79,38	112	36,50	94	50	30	28	17	M16x50	5/8x2"	4187	1,81
414	1"1/2	AFS405G114	1"1/4 GAS	32	79,38	112	36,50	94	50	30	28	17	M16x50	5/8x2"	4187	1,95
414	2"	AFS406G	2" GAS	51	96,82	134	44,45	114	65	37	30	21	M20x70	3/4x2"1/2	4225	3,31
414	2"	AFS406G112	1"1/2 GAS	38	96,82	134	44,45	114	65	37	30	21	M20x70	3/4x2"1/2	4225	3,8
414	2"1/2	AFS507G	2"1/2 GAS	63	123,80	180	58,70	152	80	45	35	26	M24x80	-	4275	6,75
414	3"	AFS508G	3" GAS	73	152,40	208	71,40	178	90	55	40	33	M30x100	-	4337	

**DESIGNAZIONE PER ORDINE  
DESIGNATION FOR ORDER**

**Materiale / Material**

**ST52.3**

**AISI 316L**

Solo flangia  
Only flange

**AFS...G**

**AFX...G**

Flangia completa di viti metriche, grower e o-ring  
Flange complete of metric screws, grower type washers and o-ring

**AFS...GM**

**AFX...GM**

Flangia completa di viti unc, grower e o-ring  
Flange complete of unc screws, grower type washers and o-ring

**AFS...GU**

**AFX...GU**

**NOTE / NOTES**

\* Per viti unc L=13,5

\* For unc screws L=13,5

(•) Solo in ST52.3

(•) Only in ST52.3

set viti unc disponibili solo in acciaio al carbonio.  
unc screws set available only in carbon steel.



# CONTROFLANGE FILETTATE GAS

## BSP THREADED COUNTER-FLANGES

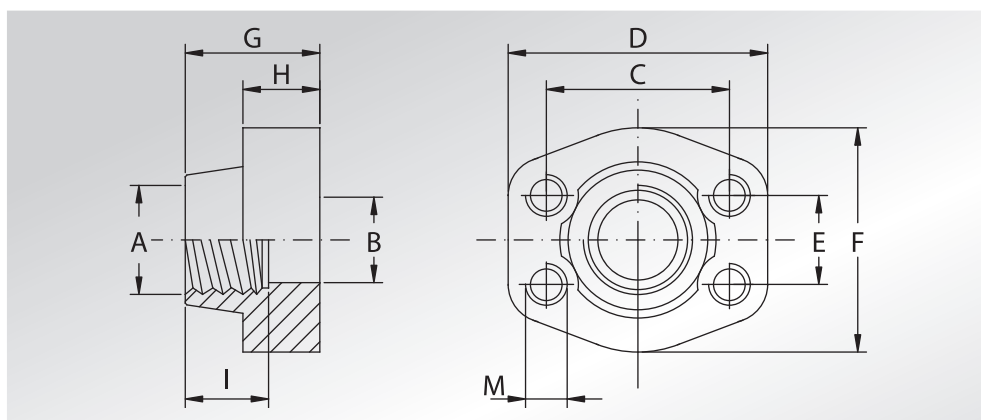

Pressione max di esercizio raccomandata Kg/cm <sup>2</sup>	Grandezza	Tipo	Dimensioni											Peso Kg	
Maximum recommended working pressure Kg/cm <sup>2</sup>	Size	Type	Dimensions											Weight Kg	
			A	B	C	D	E	F	G	H	I	Metric		Unc	
<b>SERIE 3000</b>															
345	1/2"	GFS080G	1/2" GAS	13	38,10	57	17,48	46	36	16	19	M8	5/16	0,26	
345	1/2"	GFS080G038	3/8" GAS	13	38,10	57	17,48	46	36	16	19	M8	5/16	0,28	
345	3/4"	GFS100G	3/4" GAS	19	47,63	65	22,23	50	36	18	19	M10	3/8	0,41	
345	3/4"	GFS100G012	1/2" GAS	13	47,63	65	22,23	50	36	18	19	M10	3/8	0,44	
345	1"	GFS102G	1" GAS	25	52,37	70	26,19	55	38	18	22	M10	3/8	0,49	
345	1"	GFS102G034	3/4" GAS	19	52,37	70	26,19	55	35	21	19	M10	3/8	0,55	
276	1"1/4	GFS104G	1"1/4 GAS	32	58,72	79	30,18	68	40	21	22	M10	7/16	0,71	
276	1"1/4	GFS104G100	1" GAS	25	58,72	81	30,18	65	42	25	24	M10	7/16	0,85	
207	1"1/2	GFS106G	1"1/2 GAS	38	69,85	93	35,71	78	45	25	24	M12	1/2	1,12	
207	1"1/2	GFS106G114	1"1/4 GAS	32	69,85	95	35,71	78	45	27	24	M12	1/2	1,24	
207	2"	GFS108G	2" GAS	51	77,77	102	42,88	90	45	25	30	M12	1/2	1,24	
207	2"	GFS108G112	1"1/2 GAS	38	77,77	102	42,88	90	45	25	26	M12	1/2	1,59	
172	2"1/2	GFS110G	2"1/2 GAS	63	88,90	114	50,80	105	50	25	30	M12	1/2	1,66	
173	2"1/2	GFS110G200	2" GAS	51	88,90	114	50,80	105	50	25	30	M12	1/2	2,20	
138	3"	GFS112G	3" GAS	73	106,38	134	61,93	124	50	27	34	M16	5/8	2,37	
138	3"	GFS112G212	2"1/2 GAS	63	106,38	134	61,93	124	50	27	30	M16	5/8	2,65	
34	3"1/2	GFS114G	3"1/2 GAS	89	120,65	152	69,85	136	48	27	34	M16	5/8	2,51	
34	3"1/2	GFS114G300	3" GAS	73	120,65	152	69,85	136	48	27	34	M16	5/8	3,37	
34	4"	GFS116G	4" GAS	99	130,18	162	77,77	146	48	27	34	M16	5/8	2,87	
34	4"	GFS116G312	3"1/2 GAS	89	130,18	162	77,77	146	48	27	34	M16	5/8	3,39	
34	5"	GFS118G (*)	5" GAS	120	152,40	184	92,08	180	50	28	30	M16	5/8	3,80	

### SERIE 6000

414	1/2"	GFS401G012	1/2" GAS	13	40,49	57	18,24	46	36	16	19	M8	5/16	0,26
414	1/2"	GFS401G038	3/8" GAS	13	40,49	57	18,24	46	36	16	19	M8	5/16	0,29
414	3/4"	GFS402G	3/4" GAS	19	50,80	71	23,80	55	35	21	22	M10	3/8	0,55
414	3/4"	GFS402G012	1/2" GAS	13	50,80	71	23,80	55	35	21	22	M10	3/8	0,60
414	1"	GFS403G	1" GAS	25	57,15	81	27,76	65	42	25	24	M12	7/16	0,87
414	1"	GFS403G034	3/4" GAS	19	57,15	81	27,76	65	42	25	24	M12	7/16	0,9
414	1"1/4	GFS404G	1"1/4 GAS	32	66,68	95	31,75	78	45	27	25	M14	1/2	1,21
414	1"1/4	GFS404G100	1" GAS	25	66,68	95	31,75	78	45	27	25	M14	1/2	1,34
414	1"1/2	GFS405G	1"1/2 GAS	38	79,38	112	36,50	94	50	30	28	M16	5/8	1,90
414	1"1/2	GFS405G114	1"1/4 GAS	32	79,38	112	36,50	94	50	30	28	M16	5/8	2,03
414	2"	GFS406G	2" GAS	51	96,82	134	44,45	114	65	37	30	M20	3/4	3,43
414	2"	GFS406G112	1"1/2 GAS	38	96,82	134	44,45	114	65	37	30	M20	3/4	3,92
414	2"1/2	GFS507G	2"1/2 GAS	63	123,80	180	58,70	152	80	45	35	M24	-	6,98
414	3"	GFS508G	3" GAS	73	152,40	208	71,40	178	90	55	40	M30	-	-

#### DESIGNAZIONE PER ORDINE DESIGNATION FOR ORDER

Controflangia con fori di fissaggio filettati metrici  
Counter-flange with metric threaded fixing holes

#### Materiale / Material

ST52.3      AISI 316L

**GFS...G**      **GFX...G**

Controflangia con fori di fissaggio filettati unc  
Counter-flange with unc threaded fixing holes

**GFS...GU**      **GFX...GU**

#### NOTE / NOTES

- (•) Solo in ST52.3
- (•) Only in ST52.3

**DOPPIE FLANGE  
FILETTATE  
GAS**



**BSP  
THREADED  
DOUBLE FLANGES**

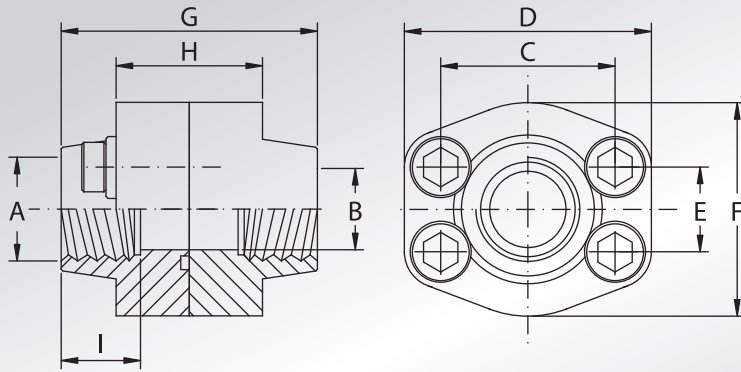

Pressione max di esercizio raccomandata Kg/cm <sup>2</sup>	Grandezza	Tipo	Dimensioni									Viti		Or tipo	Peso Kg
Maximum recommended working pressure Kg/cm <sup>2</sup>	Size	Type	Dimensions									Screws		Or type	Weight Kg
			A	B	C	D	E	F	G	H	I	Metric	Unc		

**SERIE 3000**

345	1/2"	DFS080G	1/2" GAS	13	38,10	57	17,48	46	72	32	19	M8x30	5/16x1"1/4	4075	0,57
345	1/2"	DFS080G038	3/8" GAS	13	38,10	57	17,48	46	72	32	19	M8x30	5/16x1"1/4	4075	0,61
345	3/4"	DFS100G	3/4" GAS	19	47,63	65	22,23	50	72	36	19	M10x35	3/8x1"1/2	4100	0,90
345	3/4"	DFS100G012	1/2" GAS	13	47,63	65	22,23	50	72	36	19	M10x35	3/8x1"1/2	4100	0,97
345	1"	DFS102G	1" GAS	25	52,37	70	26,19	55	76	36	22	M10x35	3/8x1"1/2	4131	1,06
345	1"	DFS102G034	3/4" GAS	19	52,37	70	26,19	55	70	42	19	M10x40	3/8x1"1/2	4131	1,19
276	1"1/4	DFS104G	1"1/4 GAS	32	58,72	79	30,18	68	80	42	22	M10x40	7/16x1"3/4	4150	1,50
276	1"1/4	DFS104G100	1" GAS	25	58,72	81	30,18	65	84	50	24	M10x40	7/16x1"3/4	4150	1,78
207	1"1/2	DFS106G	1"1/2 GAS	38	69,85	93	35,71	78	90	50	24	M12x45	1/2x1"3/4	4187	2,37
207	1"1/2	DFS106G114	1"1/4 GAS	32	69,85	95	35,71	78	90	54	24	M12x45	1/2x1"3/4	4187	2,61
207	2"	DFS108G	2" GAS	51	77,77	102	42,88	90	90	50	30	M12x45	1/2x1"3/4	4225	2,61
207	2"	DFS108G112	1"1/2 GAS	38	77,77	102	42,88	90	90	50	26	M12x45	1/2x1"3/4	4225	3,31
172	2"1/2	DFS110G	2"1/2 GAS	63	88,90	114	50,80	105	100	50	30	M12x45	1/2x1"3/4	4275	3,45
173	2"1/2	DFS110G200	2" GAS	51	88,90	114	50,80	105	100	50	30	M12x45	1/2x1"3/4	4275	4,53
138	3"	DFS112G	3" GAS	73	106,38	134	61,93	124	100	54	34	M16x50	5/8x2"	4337	5,09
138	3"	DFS112G212	2"1/2 GAS	63	106,38	134	61,93	124	100	54	30	M16x50	5/8x2"	4337	5,65
34	3"1/2	DFS114G	3"1/2 GAS	89	120,65	152	69,85	136	96	54	34	M16x50	5/8x2"	4387	5,36
34	3"1/2	DFS114G300	3" GAS	73	120,65	152	69,85	136	96	54	34	M16x50	5/8x2"	4387	7,08
34	4"	DFS116G	4" GAS	99	130,18	162	77,77	146	96	54	34	M16x50	5/8x2"	4437	6,08
34	4"	DFS116G312	3"1/2 GAS	89	130,18	162	77,77	146	96	54	34	M16x50	5/8x2"	4437	7,12
34	5"	DFS118G (*)	5" GAS	120	152,40	184	92,08	180	100	56	30	M16x50	5/8x2"	4537	8,12

**SERIE 6000**

414	1/2"	DFS401G012	1/2" GAS	13	40,49	57	18,24	46	72	32	19	M8x30	5/16x1"1/4	4075	0,57
414	1/2"	DFS401G038	3/8" GAS	13	40,49	57	18,24	46	72	32	19	M8x30	5/16x1"1/4	4075	0,63
414	3/4"	DFS402G	3/4" GAS	19	50,80	71	23,80	55	70	42	22	M10x40	3/8x1"1/2	4100	1,19
414	3/4"	DFS402G012	1/2" GAS	13	50,80	71	23,80	55	70	42	22	M10x40	3/8x1"1/2	4100	1,29
414	1"	DFS403G	1" GAS	25	57,15	81	27,76	65	84	50	24	M12x45	7/16x1"3/4	4131	1,88
414	1"	DFS403G034	3/4" GAS	19	57,15	81	27,76	65	84	50	24	M12x45	7/16x1"3/4	4131	1,94
414	1"1/4	DFS404G	1"1/4 GAS	32	66,68	95	31,75	78	90	54	25	M14x45	1/2x1"3/4	4150	2,63
414	1"1/4	DFS404G100	1" GAS	25	66,68	95	31,75	78	90	54	25	M14x45	1/2x1"3/4	4150	2,89
414	1"1/2	DFS405G	1"1/2 GAS	38	79,38	112	36,50	94	100	60	28	M16x50	5/8x2"	4187	4,14
414	1"1/2	DFS405G114	1"1/4 GAS	32	79,38	112	36,50	94	100	60	28	M16x50	5/8x2"	4187	4,41
414	2"	DFS406G	2" GAS	51	96,82	134	44,45	114	130	74	30	M20x70	3/4x2"1/2	4225	7,65
414	2"	DFS406G112	1"1/2 GAS	38	96,82	134	44,45	114	130	74	30	M20x70	3/4x2"1/2	4225	8,63
414	2"1/2	DFS507G (*)	2"1/2 GAS	63	123,80	180	58,70	152	160	90	35	M24x80	-	4275	
414	3"	DFS508G (*)	3" GAS	73	152,40	208	71,40	178	180	110	40	M30x100	-	4337	

**DESIGNAZIONE PER ORDINE  
DESIGNATION FOR ORDER**

**Materiale / Material**

**ST52.3**      **AISI 316L**

Flangia + controflangia + set viti metriche  
Flange + counter-flange + metric screws set

**DFS...GM**      **DFX...GM**

Flangia + controflangia + set viti unc  
Flange + counter-flange + unc screws set

**DFS...GU**      **DFX...GU**

**NOTE / NOTES**

(•) Solo in ST52.3  
(•) Only in ST52.3

set viti unc disponibili solo in acciaio al carbonio.  
unc screws set available only in carbon steel.

(\*) set viti disponibili solo in acciaio al carbonio.  
(\*) screws set available only in carbon steel.



# FLANGE A 90° FILETTATE GAS

## BSP THREADED 90° FLANGES

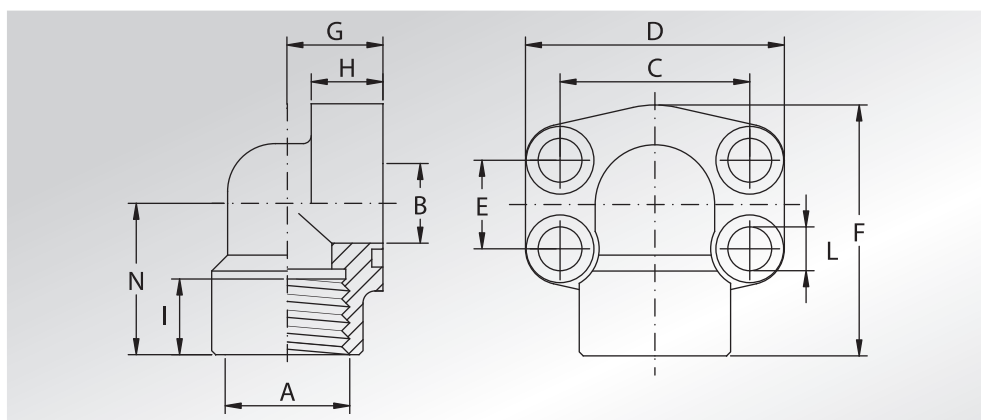

Pressione max di esercizio raccomandata Kg/cm <sup>2</sup>	Grandezza	Tipo	Dimensioni											Viti		Or tipo	Peso Kg
Maximum recommended working pressure Kg/cm <sup>2</sup>	Size	Type	Dimensions											Screws		Or type	Weight Kg
			A	B	C	D	E	F	G	H	I	L	N	Metric	Unc		

### SERIE 3000

345	1/2"	AFS08090G	1/2" GAS	13	38,10	54	17,48	60	20	16	19	9	37	M8x30	5/16x1"1/4	4075	0,28
345	1/2"	AFS08090G038	3/8" GAS	13	38,10	54	17,48	60	20	16	19	9	37	M8x30	5/16x1"1/4	4075	0,29
345	3/4"	AFS10090G	3/4" GAS	19	47,63	65	22,23	63	24	18	19	11	38	M10x35	3/8x1"1/2	4100	0,45
345	3/4"	AFS10090G012	1/2" GAS	19	47,63	65	22,23	63	24	18	19	11	38	M10x35	3/8x1"1/2	4100	0,48
345	1"	AFS10290G	1" GAS	25	52,37	70	26,19	70	28	19	20	11	43	M10x35	3/8x1"1/2	4131	0,56
345	1"	AFS10290G034	3/4" GAS	25	52,37	70	26,19	70	28	19	20	11	43	M10x40	3/8x1"1/2	4131	0,60
276	1"1/4	AFS10490G	1"1/4 GAS	32	58,72	79	30,18	85	34	21	22	11,5	51	M10x40	7/16x1"3/4	4150	0,89
276	1"1/4	AFS10490G100	1" GAS	32	58,72	79	30,18	85	34	21	22	11,5	51	M10x40	7/16x1"3/4	4150	0,92
207	1"1/2	AFS10690G	1"1/2 GAS	38	69,85	93	35,71	95	38	25	25	13,5	56	M12x45	1/2x1"3/4	4187	1,18
207	1"1/2	AFS10690G114	1"1/4 GAS	38	69,85	93	35,71	95	38	25	25	13,5	56	M12x45	1/2x1"3/4	4187	1,21
207	2"	AFS10890G	2" GAS	51	77,77	110	42,88	110	42	25	28	13,5	65	M12x45	1/2x1"3/4	4225	2,06
207	2"	AFS10890G112	1"1/2 GAS	51	77,77	110	42,88	110	42	25	28	13,5	65	M12x45	1/2x1"3/4	4225	2,10

### SERIE 6000

414	1/2"	AFS40190G012	1/2" GAS	13	40,49	54	18,24	60	20	16	19	9	37	M8x30	5/16x1"1/4	4075	0,28
414	1/2"	AFS40190G038	3/8" GAS	13	40,49	54	18,24	60	20	16	19	9	37	M8x30	5/16x1"1/4	4075	0,29
414	3/4"	AFS40290G	3/4" GAS	19	50,80	70	23,80	70	28	19	20	11	43	M10x35	3/8x1"1/2	4100	0,69
414	3/4"	AFS40290G012	1/2" GAS	19	50,80	70	23,80	70	28	19	20	11	43	M10x35	3/8x1"1/2	4100	0,72
414	1"	AFS40390G	1" GAS	25	57,15	79	27,76	85	34	21	22	13	51	M12x45	7/16x1"3/4	4131	1,11
414	1"	AFS40390G034	3/4" GAS	25	57,15	79	27,76	85	34	21	22	13	51	M12x45	7/16x1"3/4	4131	1,15
414	1"1/4	AFS40490G	1"1/4 GAS	32	66,68	93	31,75	95	38	25	25	15 *	56	M14x45	1/2x1"3/4	4150	1,45
414	1"1/4	AFS40490G100	1" GAS	32	66,68	93	31,75	95	38	25	25	15 *	56	M14x45	1/2x1"3/4	4150	1,50
414	1"1/2	AFS40590G	1"1/2 GAS	38	79,38	110	36,50	110	42	25	28	17	65	M16x50	5/8x2"	4187	2,75
414	1"1/2	AFS40590G114	1"1/4 GAS	38	79,38	110	36,50	110	42	25	28	17	65	M16x50	5/8x2"	4187	2,80
414	2"	AFS40690G	2" GAS	51	96,82	134	44,45	132	45	35	33	21	75	M20x70	3/4x2"1/2	4225	3,95
414	2"	AFS40690G112	1"1/2 GAS	51	96,82	134	44,45	132	45	35	33	21	75	M20x70	3/4x2"1/2	4225	4,40

DESIGNAZIONE PER ORDINE DESIGNATION FOR ORDER	Materiale / Material	
	ST52.3	AISI 316L
Solo flangia Only flange	<b>AFS...90G</b>	<b>AFX...90G</b>
Flangia completa di viti metriche, grower e o-ring Flange complete of metric screws, grower type washers and o-ring	<b>AFS...90GM</b>	<b>AFX...90GM</b>
Flangia completa di viti unc, grower e o-ring Flange complete of unc screws, grower type washers and o-ring	<b>AFS...90GU</b>	<b>AFX...90GU</b>

### NOTE / NOTES

- \* Per viti unc L=13,5
- \* For unc screws L=13,5

set viti unc disponibili solo in acciaio al carbonio.  
unc screws set available only in carbon steel.



**FLANGE A 90°  
FILETTATE  
GAS**



**BSP  
THREADED  
90° FLANGES**

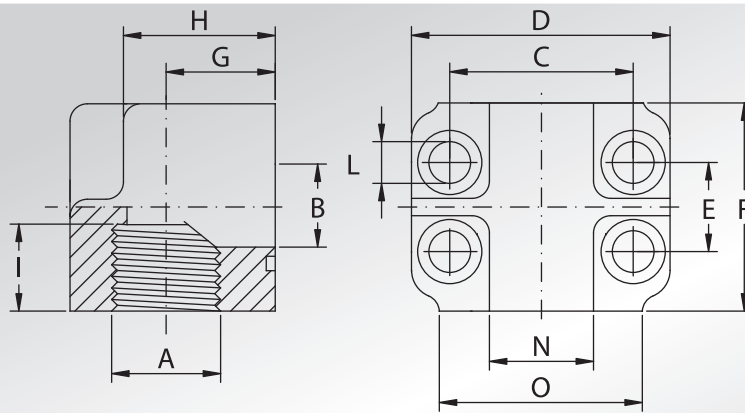

Pressione max di esercizio raccomandata Kg/cm <sup>2</sup>	Grandezza	Tipo	Dimensioni											Viti	Or tipo	Peso Kg	
			Dimensions														Screws
Maximum recommended working pressure Kg/cm <sup>2</sup>	Size	Type	A	B	C	D	E	F	G	H	I	L	N	O	Metric		

**SERIE 3000**

345	3/4"	AFS20090G	3/4" GAS	19	47,63	66	22,23	46	19	27	19	11	28	48	M10x45	4100	0,52
345	1"	AFS20290G	1" GAS	25	52,37	71	26,19	55	22	34	19	11	32	50	M10x50	4131	0,87
276	1"1/4	AFS20490G	1"1/4 GAS	32	58,72	81	30,18	65	27	42	22	11,5	35	60	M10x60	4150	1,35
207	1"1/2	AFS20690G	1"1/2 GAS	38	69,85	95	35,71	75	32	50	24	13,5	42	70	M12x70	4187	2,15
207	2"	AFS20890G	2" GAS	51	77,77	112	42,88	90	40	63	26	13,5	50	80	M12x80	4225	3,70
172	2"1/2	AFS21090G *	2"1/2 GAS	63	88,90	120	50,80	120	53	99	30	13,5	-	-	-	4275	8,20

**SERIE 6000**

414	3/4"	AFS70090G	3/4" GAS	19	50,80	71	23,80	55	22	34	22	11	32	50	M10x50	4100	0,97
414	1"	AFS70290G	1" GAS	25	57,15	81	27,76	65	27	42	24	13	35	60	M12x60	4131	1,50
414	1"1/4	AFS70490G	1"1/4 GAS	32	66,68	95	31,75	75	32	50	25	15	42	70	M14x70	4150	2,29
414	1"1/2	AFS70690G	1"1/2 GAS	38	79,38	112	36,50	90	40	63	28	17	50	80	M16x90	4187	4,08

**DESIGNAZIONE PER ORDINE  
DESIGNATION FOR ORDER**

**Materiale / Material**

**NOTE / NOTES**

Solo flangia  
Only flange

**AFS...90G**

\* Ricavata da barra.  
\* Obtained from bar.

Flangia completa di viti metriche, grower e o-ring  
Flange complete of metric screws, grower type washers and o-ring

**AFS...90GM**



# FLANGE FILETTATE NPT

## NPT THREADED FLANGES

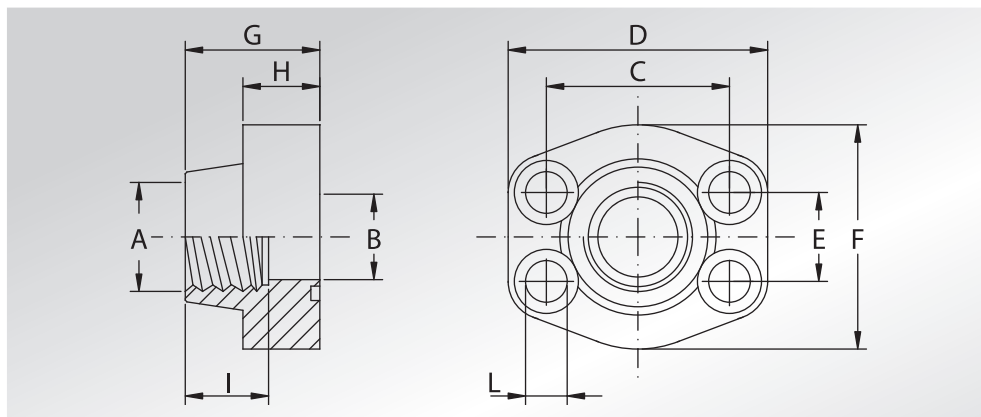

Pressione max di esercizio raccomandata Kg/cm <sup>2</sup>	Grandezza	Tipo	Dimensioni										Viti		Or tipo	Peso Kg
Maximum recommended working pressure Kg/cm <sup>2</sup>	Size	Type	Dimensions										Screws		Or type	Weight Kg
			A	B	C	D	E	F	G	H	I	L	Metric	Unc		

### SERIE 3000

345	1/2"	AFS080N	1/2" NPT	13	38,10	57	17,48	46	36	16	19	9	M8x30	5/16x1"1/4	4075	0,25
345	1/2"	AFS080N038	3/8" NPT	13	38,10	57	17,48	46	36	16	19	9	M8x30	5/16x1"1/4	4075	0,27
345	3/4"	AFS100N	3/4" NPT	19	47,63	65	22,23	50	36	18	19	11	M10x35	3/8x1"1/2	4100	0,37
345	3/4"	AFS100N012	1/2" NPT	13	47,63	65	22,23	50	36	18	19	11	M10x35	3/8x1"1/2	4100	0,40
345	1"	AFS102N	1" NPT	25	52,37	70	26,19	55	38	18	22	11	M10x35	3/8x1"1/2	4131	0,45
345	1"	AFS102N034	3/4" NPT	19	52,37	70	26,19	55	35	21	19	11	M10x40	3/8x1"1/2	4131	0,51
276	1"1/4	AFS104N	1"1/4 NPT	32	58,72	79	30,18	68	41	21	22	11,5	M10x40	7/16x1"3/4	4150	0,66
276	1"1/4	AFS104N100	1" NPT	25	58,72	81	30,18	65	42	25	24	11,5	M10x40	7/16x1"3/4	4150	0,80
207	1"1/2	AFS106N	1"1/2 NPT	38	69,85	93	35,71	78	45	25	24	13,5	M12x45	1/2x1"3/4	4187	1,05
207	1"1/2	AFS106N114	1"1/4 NPT	32	69,85	95	35,71	78	45	27	24	13,5	M12x45	1/2x1"3/4	4187	1,17
207	2"	AFS108N	2" NPT	51	77,77	102	42,88	90	45	25	30	13,5	M12x45	1/2x1"3/4	4225	1,17
207	2"	AFS108N112	1"1/2 NPT	38	77,77	102	42,88	90	45	25	26	13,5	M12x45	1/2x1"3/4	4225	1,52
172	2"1/2	AFS110N	2"1/2 NPT	63	88,90	114	50,80	105	50	25	30	13,5	M12x45	1/2x1"3/4	4275	1,59
138	3"	AFS112N	3" NPT	73	106,38	134	61,93	124	50	27	34	17,5	M16x50	5/8x2"	4337	2,28
34	3"1/2	AFS114N	3"1/2 NPT	89	120,65	152	69,85	136	48	27	34	17,5	M16x50	5/8x2"	4387	2,42
34	4"	AFS116N	4" NPT	99	130,18	162	77,77	146	48	27	34	17,5	M16x50	5/8x2"	4437	2,78
34	5"	AFS118N (*)	5" NPT	120	152,40	184	92,08	180	50	28	30	17,5	M16x50	5/8x2"	4537	3,80

### SERIE 6000

414	1/2"	AFS401N012	1/2" NPT	13	40,49	57	18,24	46	36	16	19	9	M8x30	5/16x1"1/4	4075	0,25
414	1/2"	AFS401N038	3/8" NPT	13	40,49	57	18,24	46	36	16	19	9	M8x30	5/16x1"1/4	4075	0,28
414	3/4"	AFS402N	3/4" NPT	19	50,80	71	23,80	55	35	21	22	11	M10x40	3/8x1"1/2	4100	0,51
414	3/4"	AFS402N012	1/2" NPT	13	50,80	71	23,80	55	35	21	22	11	M10x40	3/8x1"1/2	4100	0,56
414	1"	AFS403N	1" NPT	25	57,15	81	27,76	65	42	25	24	13	M12x45	7/16x1"3/4	4131	0,81
414	1"	AFS403N034	3/4" NPT	19	57,15	81	27,76	65	42	25	24	13	M12x45	7/16x1"3/4	4131	0,84
414	1"1/4	AFS404N	1"1/4 NPT	32	66,68	95	31,75	78	45	27	25	15 *	M14x45	1/2x1"3/4	4150	1,13
414	1"1/4	AFS404N100	1" NPT	25	66,68	95	31,75	78	45	27	25	15 *	M14x45	1/2x1"3/4	4150	1,26
414	1"1/2	AFS405N	1"1/2 NPT	38	79,38	112	36,50	94	50	30	28	17	M16x50	5/8x2"	4187	1,81
414	1"1/2	AFS405N114	1"1/4 NPT	32	79,38	112	36,50	94	50	30	28	17	M16x50	5/8x2"	4187	1,95
414	2"	AFS406N	2" NPT	51	96,82	134	44,45	114	65	37	30	21	M20x70	3/4x2"1/2	4225	3,31
414	2"	AFS406N112	1"1/2 NPT	38	96,82	134	44,45	114	65	37	30	21	M20x70	3/4x2"1/2	4225	3,8
414	2"1/2	AFS507N	2"1/2 NPT	63	123,80	180	58,70	152	80	45	35	26	M24x80	-	4275	6,75
414	3"	AFS508N	3" NPT	73	152,40	208	71,40	178	90	55	40	33	M30x100	-	4337	-

DESIGNAZIONE PER ORDINE DESIGNATION FOR ORDER	Materiale / Material	
	ST52.3	AISI 316L
Solo flangia Only flange	<b>AFS...N</b>	<b>AFX...N</b>
Flangia completa di viti metriche, grower e o-ring Flange complete of metric screws, grower type washers and o-ring	<b>AFS...NM</b>	<b>AFX...NM</b>
Flangia completa di viti unc, grower e o-ring Flange complete of unc screws, grower type washers and o-ring	<b>AFS...NU</b>	<b>AFX...NU</b>

#### NOTE / NOTES

\* Per viti unc L=13,5  
\* For unc screws L=13,5

(•) Solo in ST52.3  
(•) Only in ST52.3

set viti unc disponibili solo in acciaio al carbonio.  
unc screws set available only in carbon steel.

**CONTROFLANGE  
FILETTATE  
NPT**



**NPT  
THREADED  
COUNTER-FLANGES**

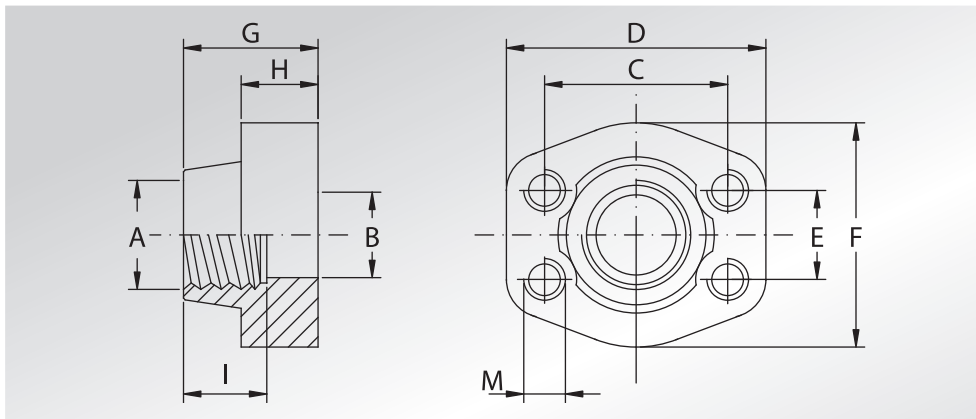

Pressione max di esercizio raccomandata Kg/cm <sup>2</sup>	Grandezza	Tipo	Dimensioni										Peso Kg	
			A	B	C	D	E	F	G	H	I	M		
Maximum recommended working pressure Kg/cm <sup>2</sup>	Size	Type	Dimensions										Weight Kg	
<b>SERIE 3000</b>														
												Metric	Unc	
345	1/2"	GFS080N	1/2" NPT	13	38,10	57	17,48	46	36	16	19	M8	5/16	0,26
345	1/2"	GFS080N038	3/8" NPT	13	38,10	57	17,48	46	36	16	19	M8	5/16	0,28
345	3/4"	GFS100N	3/4" NPT	19	47,63	65	22,23	50	36	18	19	M10	3/8	0,41
345	3/4"	GFS100N012	1/2" NPT	13	47,63	65	22,23	50	36	18	19	M10	3/8	0,44
345	1"	GFS102N	1" NPT	25	52,37	70	26,19	55	38	18	22	M10	3/8	0,49
345	1"	GFS102N034	3/4" NPT	19	52,37	70	26,19	55	35	21	19	M10	3/8	0,55
276	1"1/4	GFS104N	1"1/4 NPT	32	58,72	79	30,18	68	41	21	22	M10	7/16	0,71
276	1"1/4	GFS104N100	1" NPT	25	58,72	81	30,18	65	42	25	24	M10	7/16	0,85
207	1"1/2	GFS106N	1"1/2 NPT	38	69,85	93	35,71	78	45	25	24	M12	1/2	1,12
207	1"1/2	GFS106N114	1"1/4 NPT	32	69,85	95	35,71	78	45	27	24	M12	1/2	1,24
207	2"	GFS108N	2" NPT	51	77,77	102	42,88	90	45	25	30	M12	1/2	1,24
207	2"	GFS108N112	1"1/2 NPT	38	77,77	102	42,88	90	45	25	26	M12	1/2	1,59
172	2"1/2	GFS110N	2"1/2 NPT	63	88,90	114	50,80	105	50	25	30	M12	1/2	1,66
138	3"	GFS112N	3" NPT	73	106,38	134	61,93	124	50	27	34	M16	5/8	2,37
34	3"1/2	GFS114N	3"1/2 NPT	89	120,65	152	69,85	136	48	27	34	M16	5/8	2,51
34	4"	GFS116N	4" NPT	99	130,18	162	77,77	146	48	27	34	M16	5/8	2,87
34	5"	GFS118N(•)	5" NPT	120	152,40	184	92,08	180	50	28	30	M16	5/8	3,80

**SERIE 6000**

414	1/2"	GFS401N012	1/2" NPT	13	40,49	57	18,24	46	36	16	19	M8	5/16	0,26
414	1/2"	GFS401N038	3/8" NPT	13	40,49	57	18,24	46	36	16	19	M8	5/16	0,29
414	3/4"	GFS402N	3/4" NPT	19	50,80	71	23,80	55	35	21	22	M10	3/8	0,55
414	3/4"	GFS402N012	1/2" NPT	13	50,80	71	23,80	55	35	21	22	M10	3/8	0,60
414	1"	GFS403N	1" NPT	25	57,15	81	27,76	65	42	25	24	M12	7/16	0,87
414	1"	GFS403N034	3/4" NPT	19	57,15	81	27,76	65	42	25	24	M12	7/16	0,9
414	1"1/4	GFS404N	1"1/4 NPT	32	66,68	95	31,75	78	45	27	25	M14	1/2	1,21
414	1"1/4	GFS404N100	1" NPT	25	66,68	95	31,75	78	45	27	25	M14	1/2	1,34
414	1"1/2	GFS405N	1"1/2 NPT	38	79,38	112	36,50	94	50	30	28	M16	5/8	1,90
414	1"1/2	GFS405N114	1"1/4 NPT	32	79,38	112	36,50	94	50	30	28	M16	5/8	2,03
414	2"	GFS406N	2" NPT	51	96,82	134	44,45	114	65	37	30	M20	3/4	3,43
414	2"	GFS406N112	1"1/2 NPT	38	96,82	134	44,45	114	65	37	30	M20	3/4	3,92
414	2"1/2	GFS507N	2"1/2 NPT	63	123,80	180	58,70	152	80	45	35	M24	-	6,98
414	3"	GFS508N	3" NPT	73	152,40	208	71,40	178	90	55	40	M30	-	-

**DESIGNAZIONE PER ORDINE  
DESIGNATION FOR ORDER**

**Materiale / Material**

**ST52.3**      **AISI 316L**

Controflangia con fori di fissaggio filettati metrici  
Counter-flange with metric threaded fixing holes

**GFS...N**

**GFX...N**

Controflangia con fori di fissaggio filettati unc  
Counter-flange with unc threaded fixing holes

**GFS...NU**

**GFX...NU**

**NOTE / NOTES**

- (•) Solo in ST52.3
- (•) Only in ST52.3



# DOPPIE FLANGE FILETTATE NPT

## NPT THREADED DOUBLE FLANGES

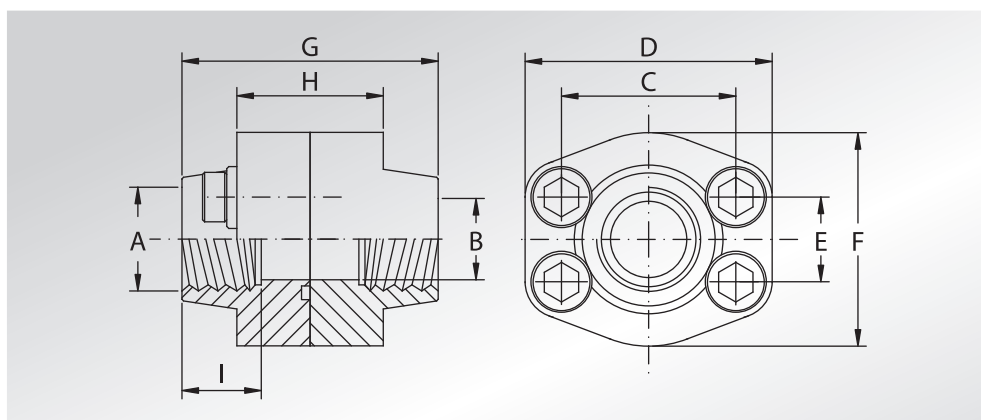

Pressione max di esercizio raccomandata Kg/cm <sup>2</sup>	Grandezza	Tipo	Dimensioni									Viti		Or tipo	Peso Kg
Maximum recommended working pressure Kg/cm <sup>2</sup>	Size	Type	Dimensions									Screws		Or type	Weight Kg
			A	B	C	D	E	F	G	H	I	Metric	Unc		

### SERIE 3000

345	1/2"	DFS080N	1/2" NPT	13	38,10	57	17,48	46	72	32	19	M8x30	5/16x1"1/4	4075	0,57
345	1/2"	DFS080N038	3/8" NPT	13	38,10	57	17,48	46	72	32	19	M8x30	5/16x1"1/4	4075	0,61
345	3/4"	DFS100N	3/4" NPT	19	47,63	65	22,23	50	72	36	19	M10x35	3/8x1"1/2	4100	0,90
345	3/4"	DFS100N012	1/2" NPT	13	47,63	65	22,23	50	72	36	19	M10x35	3/8x1"1/2	4100	0,97
345	1"	DFS102N	1" NPT	25	52,37	70	26,19	55	76	36	22	M10x35	3/8x1"1/2	4131	1,06
345	1"	DFS102N034	3/4" NPT	19	52,37	70	26,19	55	70	42	19	M10x40	3/8x1"1/2	4131	1,19
276	1"1/4	DFS104N	1"1/4 NPT	32	58,72	79	30,18	68	82	42	22	M10x40	7/16x1"3/4	4150	1,50
276	1"1/4	DFS104N100	1" NPT	25	58,72	81	30,18	65	84	50	24	M10x40	7/16x1"3/4	4150	1,78
207	1"1/2	DFS106N	1"1/2 NPT	38	69,85	93	35,71	78	90	50	24	M12x45	1/2x1"3/4	4187	2,37
207	1"1/2	DFS106N114	1"1/4 NPT	32	69,85	95	35,71	78	90	54	24	M12x45	1/2x1"3/4	4187	2,61
207	2"	DFS108N	2" NPT	51	77,77	102	42,88	90	90	50	30	M12x45	1/2x1"3/4	4225	2,61
207	2"	DFS108N112	1"1/2 NPT	38	77,77	102	42,88	90	90	50	26	M12x45	1/2x1"3/4	4225	3,31
172	2"1/2	DFS110N	2"1/2 NPT	63	88,90	114	50,80	105	100	50	30	M12x45	1/2x1"3/4	4275	3,45
138	3"	DFS112N	3" NPT	73	106,38	134	61,93	124	100	54	34	M16x50	5/8x2"	4337	5,09
34	3"1/2	DFS114N	3"1/2 NPT	89	120,65	152	69,85	136	96	54	34	M16x50	5/8x2"	4387	5,36
34	4"	DFS116N	4" NPT	99	130,18	162	77,77	146	96	54	34	M16x50	5/8x2"	4437	6,08
34	5"	DFS118N (*)	5" NPT	120	152,40	184	92,08	180	100	56	30	M16x50	5/8x2"	4537	8,12

### SERIE 6000

414	1/2"	DFS401N012	1/2" NPT	13	40,49	57	18,24	46	72	32	19	M8x30	5/16x1"1/4	4075	0,57
414	1/2"	DFS401N038	3/8" NPT	13	40,49	57	18,24	46	72	32	19	M8x30	5/16x1"1/4	4075	0,63
414	3/4"	DFS402N	3/4" NPT	19	50,80	71	23,80	55	70	42	22	M10x40	3/8x1"1/2	4100	1,19
414	3/4"	DFS402N012	1/2" NPT	13	50,80	71	23,80	55	70	42	22	M10x40	3/8x1"1/2	4100	1,29
414	1"	DFS403N	1" NPT	25	57,15	81	27,76	65	84	50	24	M12x45	7/16x1"3/4	4131	1,88
414	1"	DFS403N034	3/4" NPT	19	57,15	81	27,76	65	84	50	24	M12x45	7/16x1"3/4	4131	1,94
414	1"1/4	DFS404N	1"1/4 NPT	32	66,68	95	31,75	78	90	54	25	M14x45	1/2x1"3/4	4150	2,63
414	1"1/4	DFS404N100	1" NPT	25	66,68	95	31,75	78	90	54	25	M14x45	1/2x1"3/4	4150	2,89
414	1"1/2	DFS405N	1"1/2 NPT	38	79,38	112	36,50	94	100	60	28	M16x50	5/8x2"	4187	4,14
414	1"1/2	DFS405N114	1"1/4 NPT	32	79,38	112	36,50	94	100	60	28	M16x50	5/8x2"	4187	4,41
414	2"	DFS406N	2" NPT	51	96,82	134	44,45	114	130	74	30	M20x70	3/4x2"1/2	4225	7,65
414	2"	DFS406N112	1"1/2 NPT	38	96,82	134	44,45	114	130	74	30	M20x70	3/4x2"1/2	4225	8,63
414	2"1/2	DFS507N (*)	2"1/2 NPT	63	123,80	180	58,70	152	160	90	35	M24x80	-	4275	-
414	3"	DFS508N (*)	3" NPT	73	152,40	208	71,40	178	180	110	40	M30x100	-	4337	-

DESIGNAZIONE PER ORDINE DESIGNATION FOR ORDER	Materiale / Material	
	ST52.3	AISI 316L
Flangia + contoflangia + set viti metriche Flange + counter-flange + metric screws set	<b>DFS...NM</b>	<b>DFX...NM</b>
Flangia + contoflangia + set viti unc Flange + counter-flange + unc screws set	<b>DFS...NU</b>	<b>DFX...NU</b>

#### NOTE / NOTES

- (•) Solo in ST52.3
- (•) Only in ST52.3

set viti unc disponibili solo in acciaio al carbonio.  
unc screws set available only in carbon steel.

- (\*) set viti disponibili solo in acciaio al carbonio.
- (\*) screws set available only in carbon steel.

# FLANGE A 90° FILETTATE NPT



## NPT THREADED 90° FLANGES

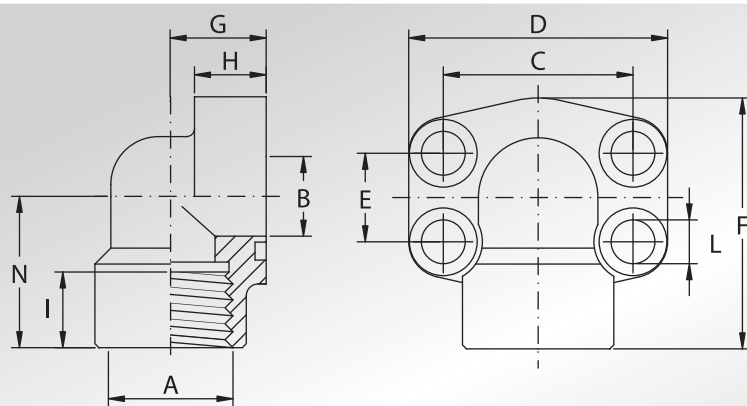

Pressione max di esercizio raccomandata Kg/cm²	Grandezza	Tipo	Dimensioni											Viti		Or tipo	Peso Kg
			Dimensions											Screws			
Maximum recommended working pressure Kg/cm²	Size	Type	A	B	C	D	E	F	G	H	I	L	N	Metric	Unc	Or type	Weight Kg

### SERIE 3000

345	1/2"	AFS08090N	1/2" NPT	13	38,10	54	17,48	60	20	16	19	9	37	M8x30	5/16x1"1/4	4075	0,28
345	1/2"	AFS08090N038	3/8" NPT	13	38,10	54	17,48	60	20	16	19	9	37	M8x30	5/16x1"1/4	4075	0,29
345	3/4"	AFS10090N	3/4" NPT	19	47,63	65	22,23	63	24	18	19	11	38	M10x35	3/8x1"1/2	4100	0,45
345	3/4"	AFS10090N012	1/2" NPT	19	47,63	65	22,23	63	24	18	19	11	38	M10x35	3/8x1"1/2	4100	0,48
345	1"	AFS10290N	1" NPT	25	52,37	70	26,19	70	28	19	20	11	43	M10x35	3/8x1"1/2	4131	0,56
345	1"	AFS10290N034	3/4" NPT	25	52,37	70	26,19	70	28	19	20	11	43	M10x40	3/8x1"1/2	4131	0,60
276	1"1/4	AFS10490N	1"1/4 NPT	32	58,72	79	30,18	85	34	21	22	11,5	51	M10x40	7/16x1"3/4	4150	0,89
276	1"1/4	AFS10490N100	1" NPT	32	58,72	79	30,18	85	34	21	22	11,5	51	M10x40	7/16x1"3/4	4150	0,92
207	1"1/2	AFS10690N	1"1/2 NPT	38	69,85	93	35,71	95	38	25	25	13,5	56	M12x45	1/2x1"3/4	4187	1,18
207	1"1/2	AFS10690N114	1"1/4 NPT	38	69,85	93	35,71	95	38	25	25	13,5	56	M12x45	1/2x1"3/4	4187	1,21
207	2"	AFS10890N	2" NPT	51	77,77	110	42,88	110	42	25	28	13,5	65	M12x45	1/2x1"3/4	4225	2,06
207	2"	AFS10890N112	1"1/2 NPT	51	77,77	110	42,88	110	42	25	28	13,5	65	M12x45	1/2x1"3/4	4225	2,10

### SERIE 6000

414	1/2"	AFS40190N012	1/2" NPT	13	40,49	54	18,24	60	20	16	19	9	37	M8x30	5/16x1"1/4	4075	0,28
414	1/2"	AFS40190N038	3/8" NPT	13	40,49	54	18,24	60	20	16	19	9	37	M8x30	5/16x1"1/4	4075	0,29
414	3/4"	AFS40290N	3/4" NPT	19	50,80	70	23,80	70	28	19	20	11	43	M10x40	3/8x1"1/2	4100	0,69
414	3/4"	AFS40290N012	1/2" NPT	19	50,80	70	23,80	70	28	19	20	11	43	M10x40	3/8x1"1/2	4100	0,72
414	1"	AFS40390N	1" NPT	25	57,15	79	27,76	85	34	21	22	13	51	M12x45	7/16x1"3/4	4131	1,11
414	1"	AFS40390N034	3/4" NPT	25	57,15	79	27,76	85	34	21	22	13	51	M12x45	7/16x1"3/4	4131	1,15
414	1"1/4	AFS40490N	1"1/4 NPT	32	66,68	93	31,75	95	38	25	25	15 *	56	M14x45	1/2x1"3/4	4150	1,45
414	1"1/4	AFS40490N100	1" NPT	32	66,68	93	31,75	95	38	25	25	15 *	56	M14x45	1/2x1"3/4	4150	1,50
414	1"1/2	AFS40590N	1"1/2 NPT	38	79,38	110	36,50	110	42	25	28	17	65	M16x50	5/8x2"	4187	2,75
414	1"1/2	AFS40590N114	1"1/4 NPT	38	79,38	110	36,50	110	42	25	28	17	65	M16x50	5/8x2"	4187	2,80
414	2"	AFS40690N	2" NPT	51	96,82	134	44,45	132	45	35	33	21	75	M20x70	3/4x2"1/2	4225	3,95
414	2"	AFS40690N112	1"1/2 NPT	51	96,82	134	44,45	132	45	35	33	21	75	M20x70	3/4x2"1/2	4225	4,40

#### DESIGNAZIONE PER ORDINE DESIGNATION FOR ORDER

Solo flangia  
Only flange

Flangia completa di viti metriche, grower e o-ring  
Flange complete of metric screws, grower type washers and o-ring

Flangia completa di viti unc, grower e o-ring  
Flange complete of unc screws, grower type washers and o-ring

#### Materiale / Material

ST52.3      AISI 316L

**AFS...90N**      **AFX...90N**

**AFS...90NM**      **AFX...90NM**

**AFS...90NU**      **AFX...90NU**

#### NOTE / NOTES

\* Per viti unc L=13,5  
\* For unc screws L=13,5

set viti unc disponibili solo in acciaio al carbonio.  
unc screws set available only in carbon steel.



# FLANGE FILETTATE METRICHE CON ATTACCO DIN 3901-3902

## DIN 3901-3902 METRIC THREADED FLANGES

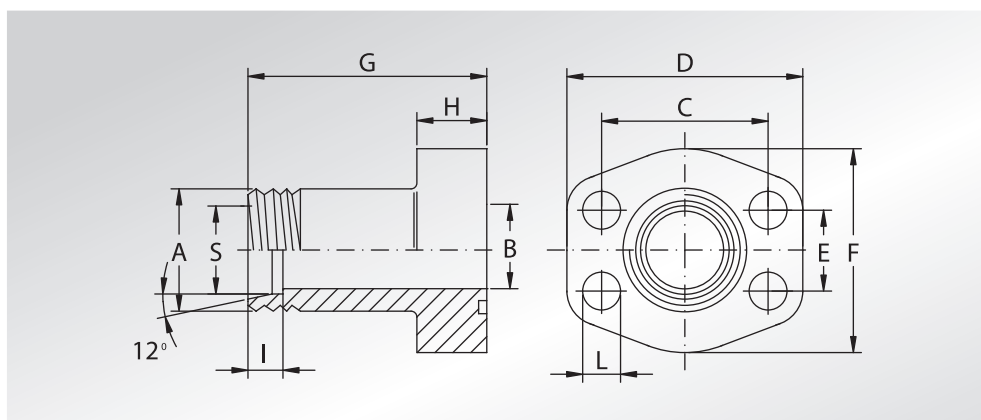

Pressione max di esercizio raccomandata Kg/cm <sup>2</sup>	Grandezza	Tipo	Dimensioni											Viti		Or tipo	Peso Kg
Maximum recommended working pressure Kg/cm <sup>2</sup>	Size	Type	Dimensions											Screws		Or type	Weight Kg
			A	B	C	D	E	F	G	H	I	L	S	Metric	Unc		

### SERIE 3000

345	1/2"	AFS080E	M22x1,5	12	38,10	54	17,48	46	52	13	7	9	15	M8x30	5/16x1"1/4	4075	0,25
345	3/4"	AFS100E	M30x2	19	47,63	65	22,23	50	60	14	7,5	11,5	22	M10x30	3/8x1"1/2	4100	0,36
345	1"	AFS102E	M36x2	24	52,37	70	26,19	55	63	16	7,5	11,5	28	M10x35	3/8x1"1/2	4131	0,50
276	1"1/4	AFS104E	M45x2	29	58,72	79	30,18	68	65	14	10,5	11,5	35	M10x35	7/16x1"3/4	4150	0,71
207	1"1/2	AFS106E	M52x2	36	69,85	94	35,71	78	70	16	11	13,5	42	M12x35	1/2x1"3/4	4187	1,02

### SERIE 6000

414	1/2"	AFS401E012	M24x1,5	12	40,49	56	18,24	48	60	16	8,5	9	16	M8x30	5/16x1"1/4	4075	0,33
414	3/4"	AFS402E	M36x2	19	50,80	71	23,80	60	73	19	12	11,5	25	M10x40	3/8x1"1/2	4100	0,68
414	1"	AFS403E	M42x2	25	57,15	81	27,76	70	82	24	13,5	13	30	M12x45	7/16x1"3/4	4131	1,03
414	1"1/4	AFS404E	M52x2	29	66,68	95	31,75	78	92	27	16	15 *	38	M14x45	1/2x1"3/4	4150	1,66
414	1"1/2	AFS405E	M52x2	32	79,38	113	36,50	95	96	30	16	17	38	M16x50	5/8x2"	4187	2,23

#### DESIGNAZIONE PER ORDINE DESIGNATION FOR ORDER

Solo flangia  
Only flange

Flangia completa di viti metriche, grower e o-ring  
Flange complete of metric screws, grower type washers and o-ring

Flangia completa di viti unc, grower e o-ring  
Flange complete of unc screws, grower type washers and o-ring

#### Materiale / Material

ST52.3

AFS...E

AFS...EM

AFS...EU

#### NOTE / NOTES

\* Per viti unc L=13,5  
\* For unc screws L=13,5

**FLANGE 90°  
FILETTATE  
METRICHE CON  
ATTACCO  
DIN 3901-3902**



**DIN 3901-3902  
METRIC THREADED  
90° FLANGES**

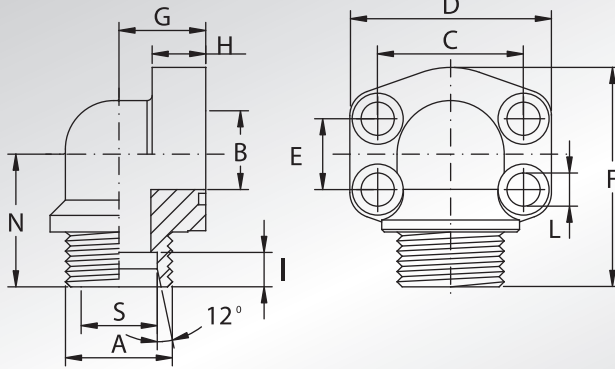

Pressione max di esercizio raccomandata Kg/cm <sup>2</sup>	Grandezza	Tipo	Dimensioni											Viti		Or tipo	Peso Kg	
Maximum recommended working pressure Kg/cm <sup>2</sup>	Size	Type	Dimensions											Screws		Or type	Weight Kg	
			A	B	C	D	E	F	G	H	I	L	N	S	Metric	Unc		

**SERIE 3000**

345	1/2"	AFS08090E	M22x1,5	12	38,10	54	17,48	60	20	16	7	9	37	15	M8x30	5/16x1"1/4	4075	0,25
345	3/4"	AFS10090E	M30x2	19	47,63	65	22,23	65	24	18	7,5	11	40	22	M10x35	3/8x1"1/2	4100	0,38
345	1"	AFS10290E	M36x2	25	52,37	70	26,19	70	28	19	12,0	11	43	28	M10x35	3/8x1"1/2	4131	0,49
276	1"1/4	AFS10490E	M45x2	32	58,72	79	30,18	86	34	21	10,5	11,5	52	35	M10x40	7/16x1"3/4	4150	0,77
207	1"1/2	AFS10690E	M52x2	38	69,85	93	35,71	95	38	25	11,0	13,5	56	42	M12x45	1/2x1"3/4	4187	1,10

**SERIE 6000**

414	1/2"	AFS40190E	M24x1,5	12	40,49	54	18,24	60	20	16	8,5	9	37	16	M8x30	5/16x1"1/4	4075	0,28
414	3/4"	AFS40290E	M36x2	19	50,80	70	23,80	70	28	19	12,0	11	43	25	M10x35	3/8x1"1/2	4100	0,69
414	1"	AFS40390E	M42x2	25	57,15	79	27,76	85	34	21	13,5	13	52	30	M12x45	7/16x1"3/4	4131	1,11
414	1"1/4	AFS40490E	M52x2	32	66,68	93	31,75	95	38	25	16,0	15 *	56	38	M14x45	1/2x1"3/4	4150	1,45
414	1"1/2	AFS40590E	M52x2	38	79,38	110	36,50	110	42	25	16,0	17	65	38	M16x50	5/8x2"	4187	2,75

**DESIGNAZIONE PER ORDINE  
DESIGNATION FOR ORDER**

**Materiale / Material**

**ST52.3      AISI 316L**

Solo flangia  
Only flange

**AFS...90E      AFX...90E**

Flangia completa di viti metriche, grower e o-ring  
Flange complete of metric screws, grower type washers and o-ring

**AFS...90EM      AFX...90EM**

Flangia completa di viti unc, grower e o-ring  
Flange complete of unc screws, grower type washers and o-ring

**AFS...90EU      AFX...90EU**

**NOTE / NOTES**

\* Per viti unc L=13,5  
\* For unc screws L=13,5

set viti unc disponibili solo in acciaio al carbonio.  
unc screws set available only in carbon steel.



# FLANGE A TENUTA CONICA A 60° FILETTATE GAS

## 60° TAPERED SEAT BSP THREADED FLANGES

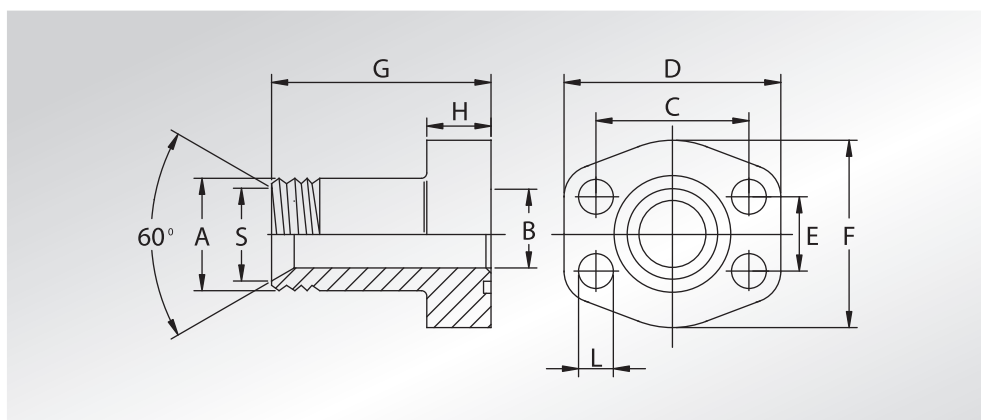

Pressione max di esercizio raccomandata Kg/cm <sup>2</sup>	Grandezza	Tipo	Dimensioni										Viti		Or tipo	Peso Kg
Maximum recommended working pressure Kg/cm <sup>2</sup>	Size	Type	Dimensions										Screws		Or type	Weight Kg
			A	B	C	D	E	F	G	H	L	S	Metric	Unc		

### SERIE 3000

345	1/2"	AFS080B	1/2" GAS	11,50	38,10	54	17,48	46	52	13	9	17,5	M8x30	5/16x1"1/4	4075	0,25
344	1/2"	AFS080B038	3/8" GAS	8,50	38,10	54	17,48	46	52	13	9	14,0	M8x30	5/16x1"1/4	4075	0,25
345	3/4"	AFS100B	3/4" GAS	17,00	47,63	65	22,23	50	60	14	11,5	22,9	M10x35	3/8x1"1/2	4100	0,36
345	3/4"	AFS100B012	1/2" GAS	11,50	47,63	65	22,23	50	60	14	11,5	17,5	M10x35	3/8x1"1/2	4100	0,36
345	1"	AFS102B	1" GAS	22,00	52,37	70	26,19	55	63	16	11,5	28,7	M10x35	3/8x1"1/2	4131	0,50
345	1"	AFS102B034	3/4" GAS	17,00	52,37	70	26,19	55	63	16	11,5	22,9	M10x40	3/8x1"1/2	4131	0,50
276	1"1/4	AFS104B	1"1/4 GAS	28,50	58,72	79	30,18	68	65	14	11,5	36,8	M10x35	7/16x1"3/4	4150	0,72
276	1"1/4	AFS104B100	1" GAS	22,00	58,72	79	30,18	68	65	14	11,5	28,7	M10x35	7/16x1"3/4	4150	0,72
207	1"1/2	AFS106B	1"1/2 GAS	34,00	69,85	94	35,71	78	70	16	13,5	42,7	M12x35	1/2x1"3/4	4187	1,00
207	1"1/2	AFS106B114	1"1/4 GAS	28,50	69,85	94	35,71	78	70	16	13,5	36,8	M12x35	1/2x1"3/4	4187	1,00

### SERIE 6000

414	1/2"	AFS401B012	1/2" GAS	11,50	40,49	56	18,24	48	60	16	9	17,5	M8x30	5/16x1"1/4	4075	0,33
414	1/2"	AFS401B038	3/8" GAS	8,50	40,49	56	18,24	48	60	16	9	14,0	M8x30	5/16x1"1/5	4075	0,33
414	3/4"	AFS402B	3/4" GAS	17,00	50,80	71	23,80	60	73	19	11,5	22,9	M10x40	3/8x1"1/2	4100	0,68
414	3/4"	AFS402B012	1/2" GAS	11,50	50,80	71	23,80	60	73	19	11,5	17,5	M10x40	3/8x1"1/3	4100	0,68
414	1"	AFS403B	1" GAS	22,00	57,15	81	27,76	70	82	24	13	28,7	M12x45	7/16x1"3/4	4131	1,00
414	1"	AFS403B034	3/4" GAS	17,00	57,15	81	27,76	70	82	24	13	22,9	M12x45	7/16x1"3/5	4131	1,00
414	1"1/4	AFS404B	1"1/4 GAS	28,50	66,68	95	31,75	78	92	27	15 *	36,8	M14x45	1/2x1"3/4	4150	1,60
414	1"1/4	AFS404B100	1" GAS	22,00	66,68	95	31,75	78	92	27	15 *	28,7	M14x45	1/2x1"3/5	4150	1,60
414	1"1/2	AFS405B	1"1/2 GAS	34,00	79,38	113	36,50	95	96	30	17	42,7	M16x50	5/8x2"	4187	2,20
414	1"1/2	AFS405B114	1"1/4 GAS	28,50	79,38	113	36,50	95	96	30	17	36,8	M16x50	5/8x2"	4187	2,20

#### DESIGNAZIONE PER ORDINE DESIGNATION FOR ORDER

Solo flangia  
Only flange

Flangia completa di viti metriche, grower e o-ring  
Flange complete of metric screws, grower type washers and o-ring

Flangia completa di viti unc, grower e o-ring  
Flange complete of unc screws, grower type washers and o-ring

#### Materiale / Material

ST52.3

AFS...B

AFS...BM

AFS...BU

#### NOTE / NOTES

\* Per viti unc L=13,5  
\* For unc screws L=13,5



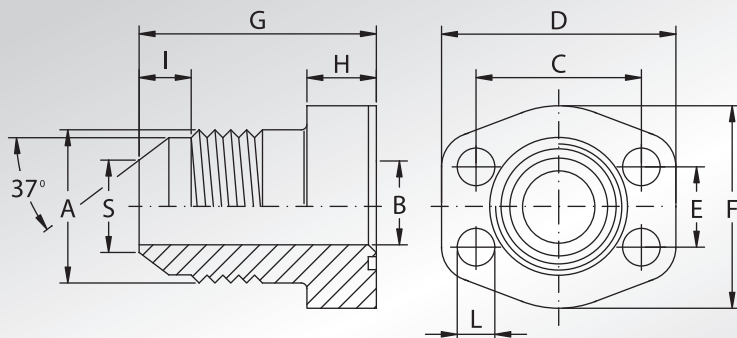

Pressione max di esercizio raccomandata Kg/cm <sup>2</sup>	Grandezza	Tipo	Dimensioni											Viti		Or tipo	Peso Kg
Maximum recommended working pressure Kg/cm <sup>2</sup>	Size	Type	Dimensions											Screws		Or type	Weight Kg
			A	B	C	D	E	F	G	H	I	L	S	Metric	Unc		

**SERIE 3000**

345	1/2"	AFS080J034	3/4" - 16UNF	9,90	38,10	54	17,48	46	52	13	6,4	9	10,82	M8x30	5/16x1"1/4	4075	0,25
345	1/2"	AFS080J078	7/8" - 14UN	12,30	38,10	54	17,48	46	52	13	6,8	9	13,69	M8x30	5/16x1"1/4	4075	0,30
345	3/4"	AFS100J	1"1/16 - 12UN	15,50	47,63	65	22,23	50	60	14	8,0	11,5	16,87	M10x35	3/8x1"1/2	4100	0,36
345	1"	AFS102J	1"5/16 - 12UN	21,50	52,37	70	26,19	55	63	16	8,0	11,5	23,19	M10x35	3/8x1"1/2	4131	0,50
276	1"1/4	AFS104J	1"5/8 - 12UN	27,50	58,72	79	30,18	68	65	14	9,3	11,5	29,13	M10x35	7/16x1"3/4	4150	0,71
207	1"1/2	AFS106J	1"7/8 - 12UN	33,00	69,85	94	35,71	78	70	16	9,6	13,5	35,08	M12x35	1/2x1"3/4	4187	1,02

**SERIE 6000**

414	1/2"	AFS401J034	3/4" - 16UNF	9,90	40,49	56	18,24	48	60	16	6,4	9	10,82	M8x30	5/16x1"1/4	4075	0,33
414	1/2"	AFS401J078	7/8" - 14UN	12,30	40,49	56	18,24	48	60	16	6,8	9	13,69	M8x30	5/16x1"1/4	4075	0,40
414	3/4"	AFS402J	1"1/16 - 12UN	15,50	50,80	71	23,80	60	73	19	8,0	11,5	16,87	M10x40	3/8x1"1/2	4100	0,68
414	1"	AFS403J	1"5/16 - 12UN	21,50	57,15	81	27,76	70	82	24	8,0	13	23,19	M12x45	7/16x1"3/4	4131	1,03
414	1"1/4	AFS404J	1"5/8 - 12UN	27,50	66,68	95	31,75	78	92	27	9,3	15 *	29,13	M14x45	1/2x1"3/4	4150	1,66
414	1"1/2	AFS405J	1"7/8 - 12UN	33,00	79,38	113	36,50	95	96	30	9,6	17	35,08	M16x50	5/8x2"	4187	2,23

**DESIGNAZIONE PER ORDINE  
DESIGNATION FOR ORDER**

**Materiale / Material**

**ST52.3**

Solo flangia  
Only flange

**AFS...J**

Flangia completa di viti metriche, grower e o-ring  
Flange complete of metric screws, grower type washers and o-ring

**AFS...JM**

Flangia completa di viti unc, grower e o-ring  
Flange complete of unc screws, grower type washers and o-ring

**AFS...JU**

**NOTE / NOTES**

\* Per viti unc L=13,5

\* For unc screws L=13,5



# FLANGE A 90° FILETTATE JIC

## JIC THREADED 90° FLANGES

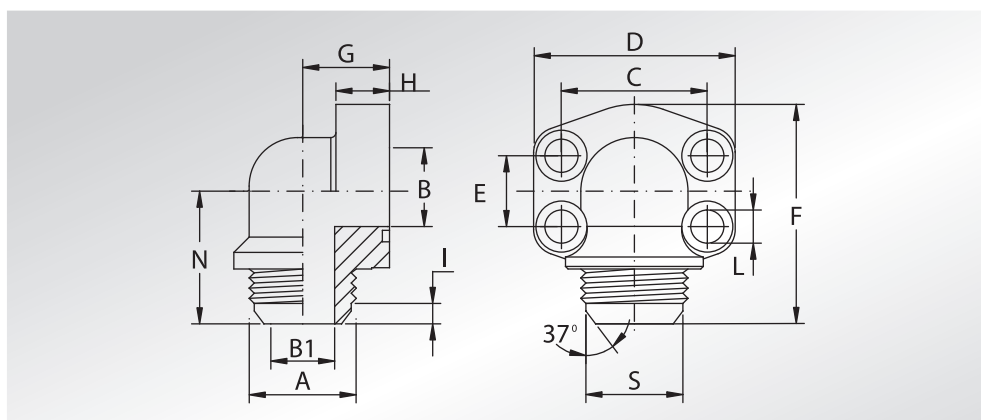

Pressione max di esercizio raccomandata Kg/cm <sup>2</sup>	Grandezza	Tipo	Dimensioni													Viti		Or tipo	Peso Kg	
Maximum recommended working pressure Kg/cm <sup>2</sup>	Size	Type	Dimensions													Screws		Or type	Weight Kg	
			A	B	B1	C	D	E	F	G	H	I	L	N	S	Metric	Unc			
<b>SERIE 3000</b>																				
345	1/2"	AFS08090J034	3/4"	- 16UNF	13	9,90	38,10	54	17,48	60	20	16	6,4	9	37	10,82	M8x30	5/16x1"1/4	4075	0,25
345	1/2"	AFS08090J078	7/8"	- 14UN	13	12,30	38,10	54	17,48	60	20	16	6,8	9	37	13,69	M8x30	5/16x1"1/4	4075	0,25
345	3/4"	AFS10090J	1"1/16	- 12UN	19	15,50	47,63	65	22,23	64	24	18	8,0	11	39	16,87	M10x35	3/8x1"1/2	4100	0,38
345	1"	AFS10290J	1"5/16	- 12UN	25	21,50	52,37	70	26,19	71	28	19	8,0	11	44	23,19	M10x35	3/8x1"1/2	4131	0,49
276	1"1/4	AFS10490J	1"5/8	- 12UN	32	27,50	58,72	79	30,18	86	34	21	9,3	11,5	52	29,13	M10x40	7/16x1"3/4	4150	0,77
207	1"1/2	AFS10690J	1"7/8	- 12UN	38	33,00	69,85	93	35,71	96	38	25	9,6	13,5	57	35,08	M12x45	1/2x1"3/4	4187	1,10

<b>SERIE 6000</b>																				
414	1/2"	AFS40190J034	3/4"	- 16UNF	13	9,90	40,49	54	18,24	60	20	16	6,4	9	37	10,82	M8x30	5/16x1"1/4	4075	0,28
414	1/2"	AFS40190J078	7/8"	- 14UN	13	12,30	40,49	54	18,24	60	20	16	6,8	9	37	13,69	M8x30	5/16x1"1/4	4075	0,28
414	3/4"	AFS40290J	1"1/16	- 12UN	19	15,50	50,80	70	23,80	71	28	19	8,0	11	44	16,87	M10x40	3/8x1"1/2	4100	0,69
414	1"	AFS40390J	1"5/16	- 12UN	25	21,50	57,15	79	27,76	85	34	21	8,0	13	51	23,19	M12x45	7/16x1"3/4	4131	1,11
414	1"1/4	AFS40490J	1"5/8	- 12UN	32	27,50	66,68	93	31,75	96	38	25	9,3	15 *	57	29,13	M14x45	1/2x1"3/4	4150	1,45
414	1"1/2	AFS40590J	1"7/8	- 12UN	38	33,00	79,38	110	36,50	111	42	25	9,6	17	66	35,08	M16x50	5/8x2"	4187	2,75

DESIGNAZIONE PER ORDINE DESIGNATION FOR ORDER	Materiale / Material	
	ST52.3	AISI 316L
Solo flangia Only flange	<b>AFS...90J</b>	<b>AFX...90J</b>
Flangia completa di viti metriche, grower e o-ring Flange complete of metric screws, grower type washers and o-ring	<b>AFS...90JM</b>	<b>AFX...90JM</b>
Flangia completa di viti unc, grower e o-ring Flange complete of unc screws, grower type washers and o-ring	<b>AFS...90JU</b>	<b>AFX...90JU</b>

### NOTE / NOTES

\* Per viti unc L=13,5  
\* For unc screws L=13,5

set viti unc disponibili solo in acciaio al carbonio.  
unc screws set available only in carbon steel.

**FLANGE  
FILETTATE "UN" CON  
FILETTO CILINDRICO  
CON SEDE O-RING**



**"UN" THREADED  
FLANGES WITH  
O-RING  
GROOVE PARALLEL  
THREAD**

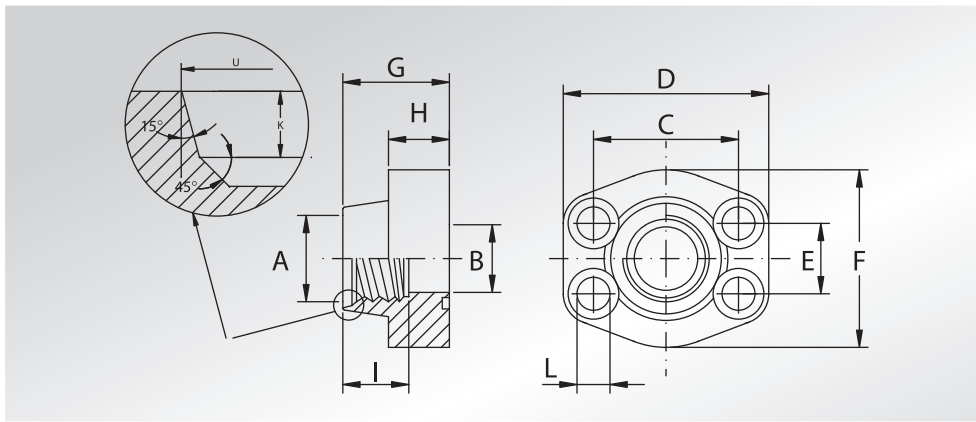

Pressione max di esercizio raccomandata Kg/cm <sup>2</sup>	Grandezza	Tipo	Dimensioni											Viti		Or tipo	Peso Kg	
Maximum recommended working pressure Kg/cm <sup>2</sup>	Size	Type	Dimensions											Screws		Or type	Weight Kg	
			A	B	C	D	E	F	G	H	I	L	U	K	Metric	Unc		

**SERIE 3000**

345	1/2"	AFS080T	3/4" - 16UNF	13	38,10	57	17,48	46	36	16	17	9	20,6	2,5	M8x30	5/16x1"1/4	4075	0,25
345	3/4"	AFS100T	1"1/16 - 12UN	19	47,63	65	22,23	50	36	18	23	11	29,2	3,3	M10x35	3/8x1"1/2	4100	0,37
345	1"	AFS102T	1"5/16 - 12UN	25	52,37	70	26,19	55	38	18	23	11	35,5	3,3	M10x35	3/8x1"1/2	4131	0,45
276	1"1/4	AFS104T	1"5/8 - 12UN	32	58,72	79	30,18	68	41	21	23	11,5	43,5	3,3	M10x40	7/16x1"3/4	4150	0,66
207	1"1/2	AFS106T	1"7/8 - 12UN	38	69,85	93	35,71	78	45	25	23	13,5	49,8	3,3	M12x45	1/2x1"3/4	4187	1,05

**SERIE 6000**

414	1/2"	AFS401T	3/4" - 16UNF	13	40,49	57	18,24	46	36	16	17	9	20,6	2,5	M8x30	5/16x1"1/4	4075	0,25
414	3/4"	AFS402T	1"1/16 - 12UN	19	50,80	71	23,80	55	35	21	23	11	29,2	3,3	M10x40	3/8x1"1/2	4100	0,51
414	1"	AFS403T	1"5/16 - 12UN	25	57,15	81	27,76	65	42	25	23	13	35,5	3,3	M12x45	7/16x1"3/4	4131	0,81
414	1"1/4	AFS404T	1"5/8 - 12UN	32	66,68	95	31,75	78	45	27	23	15 *	43,5	3,3	M14x45	1/2x1"3/4	4150	1,13
414	1"1/2	AFS405T	1"7/8 - 12UN	38	79,38	112	36,50	94	50	30	23	17	49,8	3,3	M16x50	5/8x2"	4187	1,81

**DESIGNAZIONE PER ORDINE  
DESIGNATION FOR ORDER**

**Materiale / Material**

**ST52.3      AISI 316L**

Solo flangia  
Only flange

**AFS...T**

**AFX...T**

Flangia completa di viti metriche, grower e o-ring  
Flange complete of metric screws, grower type washers and o-ring

**AFS...TM**

**AFX...TM**

Flangia completa di viti unc, grower e o-ring  
Flange complete of unc screws, grower type washers and o-ring

**AFS...TU**

**AFX...TU**

**NOTE / NOTES**

\* Per viti unc L=13,5  
\* For unc screws L=13,5

set viti unc disponibili solo in acciaio al carbonio.  
unc screws set available only in carbon steel.



## CONTROFLANGE FILETTATE "UN" CON FILETTO CILINDRICO CON SEDE O-RING

### "UN" THREADED COUNTER-FLANGES WITH O-RING GROOVE PARALLEL THREAD

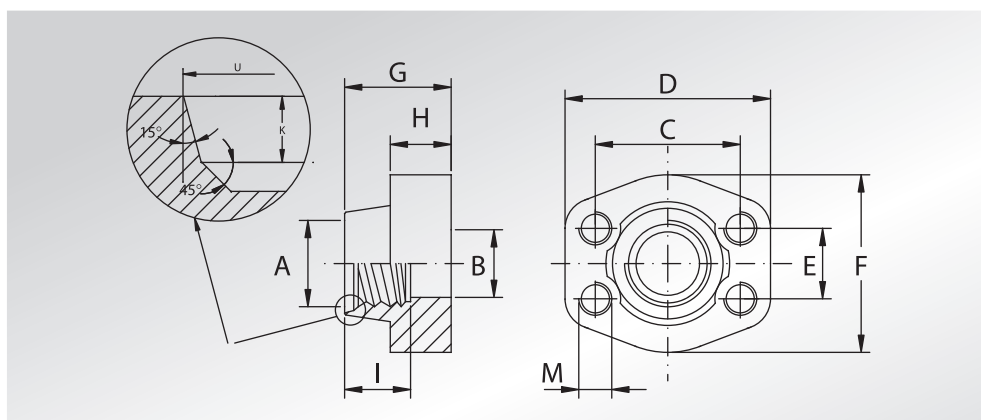

Pressione max di esercizio raccomandata Kg/cm <sup>2</sup>	Grandezza	Tipo	Dimensioni													Peso Kg
Maximum recommended working pressure Kg/cm <sup>2</sup>	Size	Type	Dimensions													Weight Kg
			A	B	C	D	E	F	G	H	I	U	K	M		
															Metric	Unc
<b>SERIE 3000</b>																
345	1/2"	GFS080T	3/4" - 16UNF	13	38,10	57	17,48	46	36	16	17	20,6	2,5	M8	5/16	0,26
345	3/4"	GFS100T	1"1/16 - 12UN	19	47,63	65	22,23	50	36	18	23	29,2	3,3	M10	3/8	0,41
345	1"	GFS102T	1"5/16 - 12UN	25	52,37	70	26,19	55	38	18	23	35,5	3,3	M10	3/8	0,49
276	1"1/4	GFS104T	1"5/8 - 12UN	32	58,72	79	30,18	68	41	21	23	43,5	3,3	M10	7/16	0,71
207	1"1/2	GFS106T	1"7/8 - 12UN	38	69,85	93	35,71	78	45	25	23	49,8	3,3	M12	1/2	1,12
<b>SERIE 6000</b>																
414	1/2"	GFS401T	3/4" - 16UNF	13	40,49	57	18,24	46	36	16	17	20,6	2,5	M8	5/16	0,26
414	3/4"	GFS402T	1"1/16 - 12UN	19	50,80	71	23,80	55	35	21	23	29,2	3,3	M10	3/8	0,55
414	1"	GFS403T	1"5/16 - 12UN	25	57,15	81	27,76	65	42	25	23	35,5	3,3	M12	7/16	0,87
414	1"1/4	GFS404T	1"5/8 - 12UN	32	66,68	95	31,75	78	45	27	23	43,5	3,3	M14	1/2	1,21
414	1"1/2	GFS405T	1"7/8 - 12UN	38	79,38	112	36,50	94	50	30	23	49,8	3,3	M16	5/8	1,88

DESIGNAZIONE PER ORDINE DESIGNATION FOR ORDER	Materiale / Material	
	ST52.3	AISI 316L
Controflangia con fori di fissaggio filettati metrici Counter-flange with metric threaded fixing holes	<b>GFS...T</b>	<b>GFX...T</b>
Controflangia con fori di fissaggio filettati unc Counter-flange with unc threaded fixing holes	<b>GFS...TU</b>	<b>GFX...TU</b>

#### NOTE / NOTES

**FLANGE A 90°  
FILETTATE "UN" CON  
FILETTO CILINDRICO  
CON SEDE O-RING**



**"UN" THREADED 90°  
FLANGES WITH  
O-RING GROOVE  
PARALLEL THREAD**

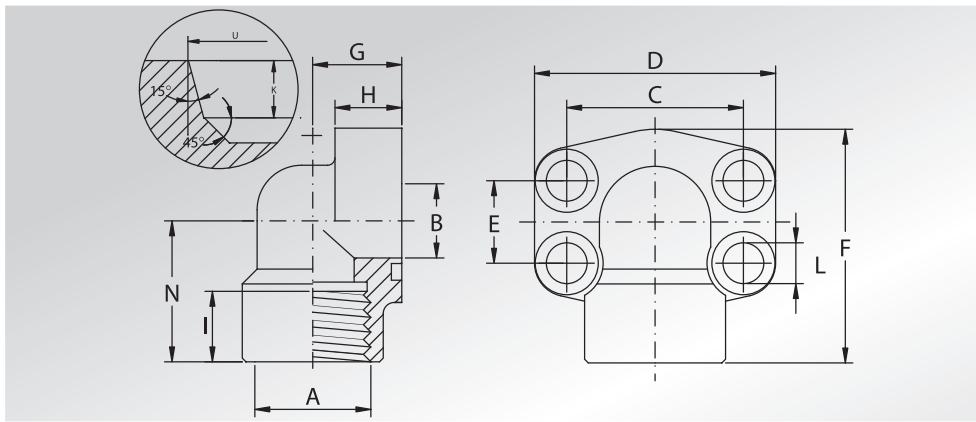

Pressione max di esercizio raccomandata Kg/cm <sup>2</sup>	Grandezza	Tipo	Dimensioni													Viti		Or tipo	Peso Kg
Maximum recommended working pressure Kg/cm <sup>2</sup>	Size	Type	Dimensions													Screws		Or type	Weight Kg
			A	B	C	D	E	F	G	H	I	L	N	U	K	Metric	Unc		

**SERIE 3000**

345	1/2"	AFS08090T	3/4" - 16 UNF	13	38,10	54	17,48	60	20	16	17	9	37	29,6	2,54	M8x30	5/16x1" 1/4	4075	0,28
345	3/4"	AFS10090T	1" 1/16 - 12 UN	19	47,63	65	22,23	63	24	18	23	11	38	29,2	3,3	M10x35	3/8x1" 1/2	4100	0,45
345	1"	AFS10290T	1" 5/16 - 12 UN	25	52,37	70	26,19	70	28	19	23	11	43	35,5	3,3	M10x35	3/8x1" 1/2	4131	0,56
276	1"1/4	AFS10490T	1" 5/8 - 12 UN	32	58,72	79	30,18	79	34	21	23	11,5	51	43,5	3,35	M10x40	7/16x1" 3/4	4150	0,89
207	1"1/2	AFS10690T	1" 7/8 - 12 UN	38	69,85	93	35,71	93	38	25	23	13,5	56,0	49,8	3,4	M12x45	1/2x1" 3/4	4187	1,18

**SERIE 6000**

414	1/2"	AFS40190T	3/4" - 16 UNF	13	40,49	54	18,24	60	20	16	17	9	37	29,6	2,54	M8x30	5/16x1" 1/4	4075	0,28
414	3/4"	AFS40290T	1" 1/16 - 12 UN	19	50,80	70	23,80	70	28	19	23	11	43	29,2	3,3	M10x35	3/8x1" 1/2	4100	0,69
414	1"	AFS40390T	1" 5/16 - 12 UN	25	57,15	79	27,76	85	34	21	23	13	51	35,5	3,3	M12x45	7/16x1" 3/4	4131	1,11
414	1"1/4	AFS40490T	1" 5/8 - 12 UN	32	66,68	93	31,75	95	38	25	23	15 *	56	43,5	3,35	M14x45	1/2x1" 3/4	4150	1,45
414	1"1/2	AFS40590T	1" 7/8 - 12 UN	38	79,38	110	36,50	110	42	25	23	17	65	49,8	3,4	M16x50	5/8x2"	4187	2,75

DESIGNAZIONE PER ORDINE DESIGNATION FOR ORDER	Materiale / Material	
	ST52.3	AISI 316L
Solo flangia Only flange	<b>AFS...90T</b>	<b>AFX...90T</b>
Flangia completa di viti metriche, grower e o-ring Flange complete of metric screws, grower type washers and o-ring	<b>AFS...90TM</b>	<b>AFX...90TM</b>
Flangia completa di viti unc, grower e o-ring Flange complete of unc screws, grower type washers and o-ring	<b>AFS...90TU</b>	<b>AFX...90TU</b>

**NOTE / NOTES**

\* Per viti unc L=13,5  
\* For unc screws L=13,5

set viti unc disponibili solo in acciaio al carbonio.  
unc screws set available only in carbon steel.



**FLANGE A 90°  
A TENUTA CONICA  
A 60°  
FILETTATE GAS**

**90° FLANGES  
WITH 60°  
TAPERED SEAT  
AND BSP THREAD**

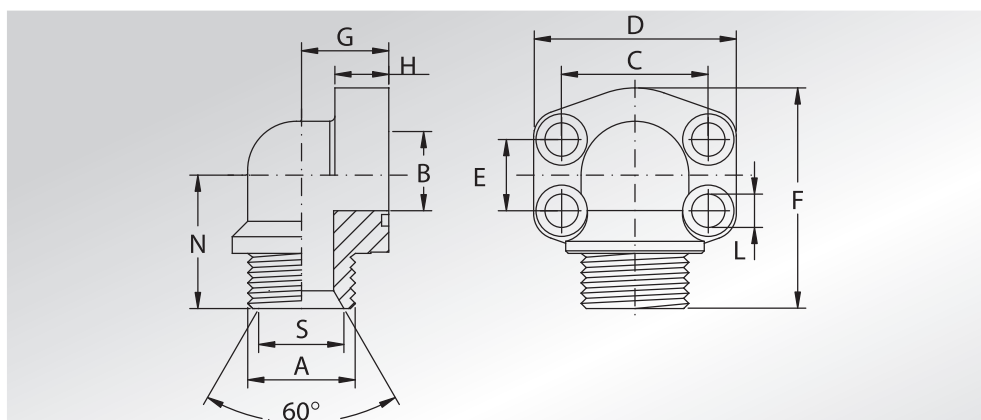

Pressione max di esercizio raccomandata Kg/cm <sup>2</sup>	Grandezza	Tipo	Dimensioni											Viti		Or tipo	Peso Kg
Maximum recommended working pressure Kg/cm <sup>2</sup>	Size	Type	Dimensions											Screws		Or type	Weight Kg
			A	B	C	D	E	F	G	H	L	N	S	Metric	Unc		

**SERIE 3000**

345	1/2"	AFS08090B	1/2" GAS	11,5 / 13	38,10	54	17,48	61	20	16	9	38	17,50	M8x30	5/16x1"1/4	4075	0,25
345	1/2"	AFS08090B038	3/8" GAS	8,5 / 13	38,10	54	17,48	61	20	16	9	38	14,00	M8x30	5/16x1"1/4	4075	0,25
345	3/4"	AFS10090B	3/4" GAS	17 / 19	47,63	65	22,23	64	24	18	11	39	22,90	M10x35	3/8x1"1/2	4100	0,38
345	1"	AFS10290B	1" GAS	22 / 25	52,37	70	26,19	70	28	19	11	43	28,70	M10x35	3/8x1"1/2	4131	0,49
276	1"1/4	AFS10490B	1"1/4 GAS	28,5 / 32	58,72	79	30,18	85	34	21	11,5	51	36,80	M10x35	7/16x1"3/4	4150	0,77
207	1"1/2	AFS10690B	1"1/2 GAS	34 / 38	69,85	93	35,71	96	38	25	13,5	56	42,70	M12x35	1/2x1"3/4	4187	1,10

**SERIE 6000**

414	1/2"	AFS40190B012	1/2" GAS	11,5 / 13	40,49	54	18,24	61	20	16	9	38	17,50	M8x30	5/16x1"1/4	4075	0,28
414	1/2"	AFS40190B038	3/8" GAS	8,5 / 13	40,49	54	18,24	61	20	16	9	38	14,00	M8x30	5/16x1"1/4	4075	0,28
414	3/4"	AFS40290B	3/4" GAS	17 / 19	50,80	70	23,80	70	28	19	11	43	22,90	M10x40	3/8x1"1/2	4100	0,69
414	1"	AFS40390B	1" GAS	22 / 25	57,15	79	27,76	85	34	21	13	51	28,70	M12x45	7/16x1"3/4	4131	1,11
414	1"1/4	AFS40490B	1"1/4 GAS	28,5 / 32	66,68	93	31,75	96	38	25	15 *	56	36,80	M14x45	1/2x1"3/4	4150	1,45
414	1"1/2	AFS40590B	1"1/2 GAS	34 / 38	79,38	110	36,50	110	42	25	17	65	42,70	M16x50	5/8x2"	4187	2,75

DESIGNAZIONE PER ORDINE DESIGNATION FOR ORDER	Materiale / Material	
	ST52.3	AISI 316L
Solo flangia Only flange	<b>AFS...90B</b>	<b>AFX...90B</b>
Flangia completa di viti metriche, grower e o-ring Flange complete of metric screws, grower type washers and o-ring	<b>AFS...90BM</b>	<b>AFX...90BM</b>
Flangia completa di viti unc, grower e o-ring Flange complete of unc screws, grower type washers and o-ring	<b>AFS...90BU</b>	<b>AFX...90BU</b>

**NOTE / NOTES**

\* Per viti unc L=13,5  
\* For unc screws L=13,5

set viti unc disponibili solo in acciaio al carbonio.  
unc screws set available only in carbon steel.

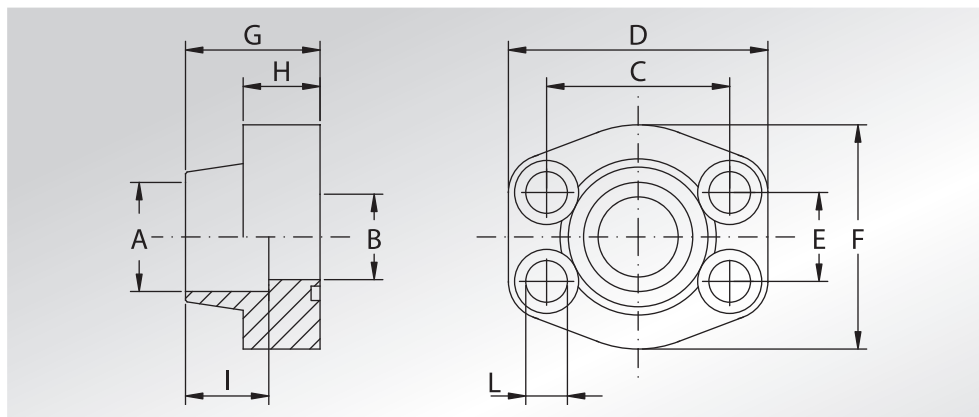

Pressione max di esercizio raccomandata Kg/cm <sup>2</sup>	Grandezza	Tipo	Dimensioni										Viti		Or tipo	Peso Kg
			Dimensions										Screws			
Maximum recommended working pressure Kg/cm <sup>2</sup>	Size	Type	A	B	C	D	E	F	G	H	I	L	Metric	Unc		

**SERIE 3000**

345	1/2"	AFS080S	21,6	13	38,10	57	17,48	46	36	16	19	9	M8x30	5/16x1"1/4	4075	0,25
345	1/2"	AFS080S038	17,5	13	38,10	57	17,48	46	36	16	19	9	M8x30	5/16x1"1/4	4075	0,27
345	3/4"	AFS100S	27,2	19	47,63	65	22,23	50	36	18	19	11	M10x35	3/8x1"1/2	4100	0,37
345	1"	AFS102S	34,0	25	52,37	70	26,19	55	38	18	19	11	M10x35	3/8x1"1/2	4131	0,45
276	1"1/4	AFS104S	42,8	32	58,72	79	30,18	68	41	21	22	11,5	M10x40	7/16x1"3/4	4150	0,66
207	1"1/2	AFS106S	48,6	38	69,85	93	35,71	78	45	25	24	13,5	M12x45	1/2x1"3/4	4187	1,03
207	2"	AFS108S	61,0	51	77,77	102	42,88	90	45	25	26	13,5	M12x45	1/2x1"3/4	4225	1,17
172	2"1/2	AFS110S	76,6	63	88,90	114	50,80	105	50	25	30	13,5	M12x45	1/2x1"3/4	4275	1,53
138	3"	AFS112S	90,5	73	106,38	134	61,93	124	50	27	34	17,5	M16x50	5/8x2"	4337	2,09
34	3"1/2	AFS114S	103,0	89	120,65	152	69,85	136	48	27	34	17,5	M16x50	5/8x2"	4387	2,35
34	4"	AFS116S	115,5	99	130,18	162	77,77	146	48	27	34	17,5	M16x50	5/8x2"	4437	2,70
34	5"	AFS118S (*)	142,0	120	152,40	184	92,08	180	50	28	28	17,5	M16x50	5/8x2"	4537	3,80

**SERIE 6000**

414	1/2"	AFS401S012	21,6	13	40,49	57	18,24	46	36	16	19	9	M8x30	5/16x1"1/4	4075	0,25
414	1/2"	AFS401S038	17,5	13	40,49	57	18,24	46	36	16	19	9	M8x30	5/16x1"1/4	4075	0,27
414	3/4"	AFS402S	27,2	19	50,80	71	23,80	55	35	21	22	11	M10x40	3/8x1"1/2	4100	0,51
414	1"	AFS403S	34,0	25	57,15	81	27,76	65	42	25	22	13	M12x45	7/16x1"3/4	4131	0,80
414	1"1/4	AFS404S	42,8	32	66,68	95	31,75	78	45	27	25	15 *	M14x45	1/2x1"3/4	4150	1,13
414	1"1/2	AFS405S	48,6	38	79,38	112	36,50	94	50	30	28	17	M16x50	5/8x2"	4187	1,86
414	2"	AFS406S	61,0	51	96,82	134	44,45	114	65	37	24	21	M20x70	3/4x2"1/2	4225	3,30
414	2"1/2	AFS507S	76,6	63	123,80	180	58,70	152	80	45	30	26	M24x80	-	4275	6,60
414	3"	AFS508S	90,5	73	152,40	208	71,40	178	90	55	30	33	M30x100	-	4337	-

**DESIGNAZIONE PER ORDINE  
DESIGNATION FOR ORDER**

**Materiale / Material**

**ST52.3**      **AISI 316L**

Solo flangia  
Only flange

**AFS...S**

**AFX...S**

Flangia completa di viti metriche, grower e o-ring  
Flange complete of metric screws, grower type washers and o-ring

**AFS...SM**

**AFX...SM**

Flangia completa di viti unc, grower e o-ring  
Flange complete of unc screws, grower type washers and o-ring

**AFS...SU**

**AFX...SU**

**NOTE / NOTES**

\* Per viti unc L=13,5  
\* For unc screws L=13,5

(•) Solo in ST52.3  
(•) Only in ST52.3

set viti unc disponibili solo in acciaio al carbonio.  
unc screws set available only in carbon steel.



# CONTROFLANGE A SALDARE DI TASCA

## WELD IN COUNTER-FLANGES

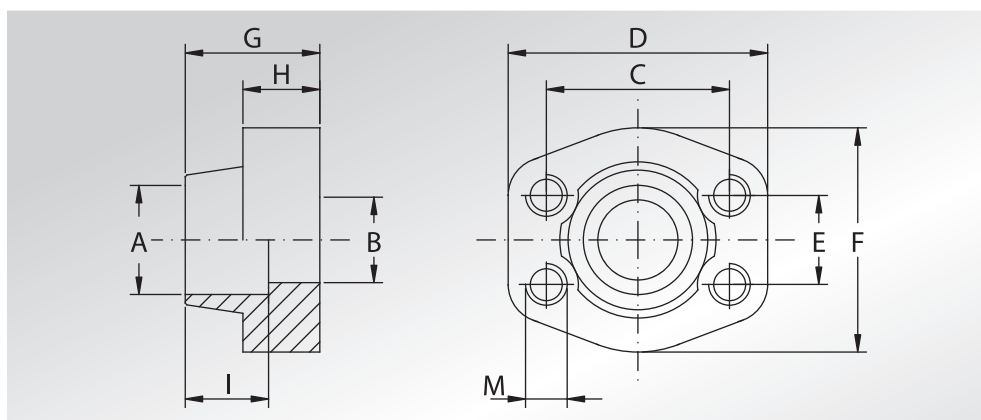

Pressione max di esercizio raccomandata Kg/cm <sup>2</sup>	Grandezza	Tipo	Dimensioni										Peso Kg	
Maximum recommended working pressure Kg/cm <sup>2</sup>	Size	Type	Dimensions										Weight Kg	
			A	B	C	D	E	F	G	H	I	M		

### SERIE 3000

													Metric	Unc	
345	1/2"	GFS080S	21,6	13	38,10	57	17,48	46	36	16	19	M8	5/16	0,25	
345	1/2"	GFS080S038	17,5	13	38,10	57	17,48	46	36	16	19	M8	5/16	0,28	
345	3/4"	GFS100S	27,2	19	47,63	65	22,23	50	36	18	19	M10	3/8	0,39	
345	1"	GFS102S	34,0	25	52,37	70	26,19	55	38	18	19	M10	3/8	0,46	
276	1"1/4	GFS104S	42,8	32	58,72	79	30,18	68	41	21	22	M10	7/16	0,71	
207	1"1/2	GFS106S	48,6	38	69,85	93	35,71	78	45	25	24	M12	1/2	1,11	
207	2"	GFS108S	61,0	51	77,77	102	42,88	90	45	25	26	M12	1/2	1,19	
172	2"1/2	GFS110S	76,6	63	88,90	114	50,80	105	50	25	30	M12	1/2	1,40	
138	3"	GFS112S	90,5	73	106,38	134	61,93	124	50	27	34	M16	5/8	2,15	
34	3"1/2	GFS114S	103,0	89	120,65	152	69,85	136	48	27	34	M16	5/8	2,40	
34	4"	GFS116S	115,5	99	130,18	162	77,77	146	48	27	34	M16	5/8	2,85	
34	5"	GFS118S (*)	142,0	120	152,40	184	92,08	180	50	28	28	M16	5/8	3,80	

### SERIE 6000

414	1/2"	GFS401S012	21,6	13	40,49	57	18,24	46	36	16	19	M8	5/16	0,26
414	1/2"	GFS401S038	17,5	13	40,49	57	18,24	46	36	16	19	M8	5/16	0,29
414	3/4"	GFS402S	27,2	19	50,80	71	23,80	55	35	21	22	M10	3/8	0,50
414	1"	GFS403S	34,0	25	57,15	81	27,76	65	42	25	22	M12	7/16	0,76
414	1"1/4	GFS404S	42,8	32	66,68	95	31,75	78	45	27	25	M14	1/2	1,20
414	1"1/2	GFS405S	48,6	38	79,38	112	36,50	94	50	30	28	M16	5/8	1,94
414	2"	GFS406S	61,0	51	96,82	134	44,45	114	65	37	24	M20	3/4	3,42
414	2"1/2	GFS507S	76,6	63	123,80	180	58,70	152	80	45	30	M24	-	6,75
414	3"	GFS508S	90,5	73	152,40	208	71,40	178	90	55	30	M30	-	-

#### DESIGNAZIONE PER ORDINE DESIGNATION FOR ORDER

Controflangia con fori di fissaggio filettati metrici  
Counter-flange with metric threaded fixing holes

#### Materiale / Material

ST52.3      AISI 316L

**GFS...S**      **GFX...S**

Controflangia con fori di fissaggio filettati unc  
Counter-flange with unc threaded fixing holes

**GFS...SU**      **GFX...SU**

#### NOTE / NOTES

- (•) Solo in ST52.3
- (•) Only in ST52.3



**FLANGE  
A SALDARE  
DI TASCA  
TUBO METRICO**



**METRIC PIPE  
WELD IN  
FLANGES**

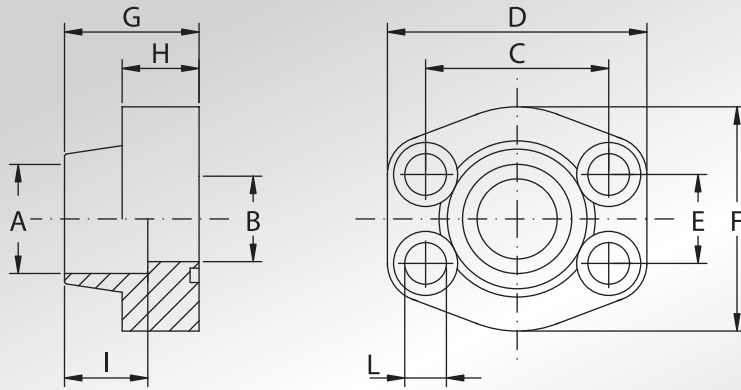

Pressione max di esercizio raccomandata Kg/cm <sup>2</sup>	Grandezza	Tipo	Dimensioni										Viti		Or tipo	Peso Kg
Maximum recommended working pressure Kg/cm <sup>2</sup>	Size	Type	Dimensions										Screws		Or type	Weight Kg
			A	B	C	D	E	F	G	H	I	L	Metric	Unc		

**SERIE 3000**

345	1/2"	AFS080SA20	20,3	13	38,10	57	17,48	46	36	16	19	9	M8x30	5/16x1"1/4	4075	0,25
345	3/4"	AFS100SA25	25,3	19	47,63	65	22,23	50	36	18	19	11	M10x35	3/8x1"1/2	4100	0,39
345	1"	AFS102SA30	30,3	25	52,37	70	26,19	55	38	18	19	11	M10x35	3/8x1"1/2	4131	0,46
276	1"1/4	AFS104SA38	38,3	32	58,72	79	30,18	68	41	21	22	11,5	M10x40	7/16x1"3/4	4150	0,66
207	1"1/2	AFS106SA50	50,5	38	69,85	93	35,71	78	45	25	24	13,5	M12x45	1/2x1"3/4	4187	1,05

**SERIE 6000**

414	1/2"	AFS401SA20	20,3	13	40,49	57	18,24	46	36	16	19	9	M8x30	5/16x1"1/4	4075	0,25
414	3/4"	AFS402SA25	25,3	19	50,80	71	23,80	55	35	21	22	11	M10x40	3/8x1"1/2	4100	0,50
414	1"	AFS403SA30	30,3	25	57,15	81	27,76	65	42	25	22	13	M12x45	7/16x1"3/4	4131	0,76
414	1"1/4	AFS404SA38	38,3	32	66,68	95	31,75	78	45	27	25	15 *	M14x45	1/2x1"3/4	4150	1,20
414	1"1/4	AFS404SA38B26	38,3	26	66,68	95	31,75	78	45	27	25	15	M14x45	-	4150	1,25
414	1"1/4	AFS404SA38B28	38,3	28	66,68	95	31,75	78	45	27	25	15	M14x45	-	4150	1,25
414	1"1/2	AFS405SAA50	50,5	38	79,38	112	36,50	94	50	30	28	17	M16x50	5/8x2"	4187	1,90

**DESIGNAZIONE PER ORDINE  
DESIGNATION FOR ORDER**

**Materiale / Material**

**ST52.3**      **AISI 316L**

Solo flangia  
Only flange

**AFS...SA**      **AFX...SA**

Flangia completa di viti metriche, grower e o-ring  
Flange complete of metric screws, grower type washers and o-ring

**AFS...SMA**      **AFX...SMA**

Flangia completa di viti unc, grower e o-ring  
Flange complete of unc screws, grower type washers and o-ring

**AFS...SUA**      **AFX...SUA**

**NOTE / NOTES**

\* Per viti unc L=13,5  
\* For unc screws L=13,5

set viti unc disponibili solo in acciaio al carbonio.  
unc screws set available only in carbon steel.



**CONTROFLANGE  
A SALDARE  
DI TASCA  
TUBO METRICO**

**METRIC PIPE  
WELD IN  
COUNTER-FLANGES**

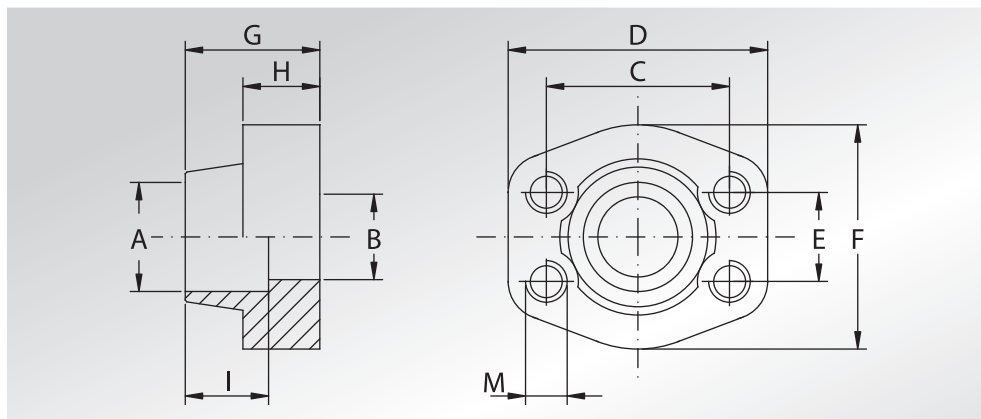

Pressione max di esercizio raccomandata Kg/cm <sup>2</sup>	Grandezza	Tipo	Dimensioni											Peso Kg	
Maximum recommended working pressure Kg/cm <sup>2</sup>	Size	Type	Dimensions											Weight Kg	
			A	B	C	D	E	F	G	H	I	Metric		Unc	
<b>SERIE 3000</b>															
345	1/2"	GFS080SA20	20,3	13	38,10	57	17,48	46	36	16	19	M8	5/16	0,26	
345	3/4"	GFS100SA25	25,3	19	47,63	65	22,23	50	36	18	19	M10	3/8	0,43	
345	1"	GFS102SA30	30,3	25	52,37	70	26,19	55	38	18	19	M10	3/8	0,50	
276	1"1/4	GFS104SA38	38,3	32	58,72	79	30,18	68	41	21	22	M10	7/16	0,71	
207	1"1/2	GFS106SA50	50,5	38	69,85	93	35,71	78	45	25	24	M12	1/2	1,12	
<b>SERIE 6000</b>															
414	1/2"	GFS401SA20	20,3	13	40,49	57	18,24	46	36	16	19	M8	5/16	0,26	
414	3/4"	GFS402SA25	25,3	19	50,80	71	23,80	55	35	21	22	M10	3/8	0,54	
414	1"	GFS403SA30	30,3	25	57,15	81	27,76	65	42	25	22	M12	7/16	0,82	
414	1"1/4	GFS404SA38	38,3	32	66,68	95	31,75	78	45	27	25	M14	1/2	1,28	
414	1"1/4	GFS404SA38B26	38	26	66,68	95	31,75	78	45	27	25	M14	1/2	1,32	
414	1"1/4	GFS404SA38B28	38	28	66,68	95	31,75	78	45	27	25	M14	1/2	1,32	
414	1"1/2	GFS405SA50	50,5	38	79,38	112	36,50	94	50	30	28	M16	5/8	1,94	

DESIGNAZIONE PER ORDINE DESIGNATION FOR ORDER	Materiale / Material	
	ST52.3	AISI 316L
Controflangia con fori di fissaggio filettati metrici Counter-flange with metric threaded fixing holes	<b>GFS...SA</b>	<b>GFX...SA</b>
Controflangia con fori di fissaggio filettati unc Counter-flange with unc threaded fixing holes	<b>GFS...SAU</b>	<b>GFX...SAU</b>

**NOTE / NOTES**

**DOPPIE FLANGE  
A SALDARE  
DI TASCA**



**WELD IN  
DOUBLE FLANGES**

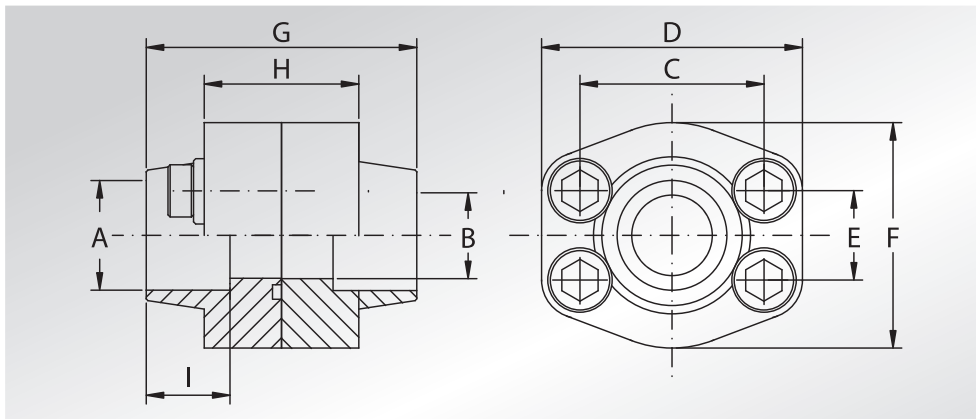

Pressione max di esercizio raccomandata Kg/cm <sup>2</sup>	Grandezza	Tipo	Dimensioni									Viti		Or tipo	Peso Kg
			Dimensions									Screws			
Maximum recommended working pressure Kg/cm <sup>2</sup>	Size	Type	A	B	C	D	E	F	G	H	I	Metric	Unc	Or type	Weight Kg

**SERIE 3000**

345	1/2"	DFS080S	21,6	13	38,10	57	17,48	46	72	32	19	M8x30	5/16x1"1/4	4075	0,56
345	1/2"	DFS080S038	17,5	13	38,10	57	17,48	46	72	32	19	M8x30	5/16x1"1/4	4075	0,61
345	3/4"	DFS100S	27,2	19	47,63	65	22,23	50	72	36	19	M10x35	3/8x1"1/2	4100	0,88
345	1"	DFS102S	34,0	25	52,37	70	26,19	55	76	36	19	M10x35	3/8x1"1/2	4131	1,03
276	1"1/4	DFS104S	42,8	32	58,72	79	30,18	68	82	42	22	M10x40	7/16x1"3/4	4150	1,50
207	1"1/2	DFS106S	48,6	38	69,85	93	35,71	78	90	50	24	M12x45	1/2x1"3/4	4187	1,65
207	2"	DFS108S	61,0	51	77,77	102	42,88	90	90	50	26	M12x45	1/2x1"3/4	4225	2,56
172	2"1/2	DFS110S	76,6	63	88,90	114	50,80	105	100	50	30	M12x45	1/2x1"3/4	4275	3,13
138	3"	DFS112S	90,5	73	106,38	134	61,93	124	100	54	34	M16x50	5/8x2"	4337	4,67
34	3"1/2	DFS114S	103,0	89	120,65	152	69,85	136	96	54	34	M16x50	5/8x2"	4387	5,18
34	4"	DFS116S	115,5	99	130,18	162	77,77	146	96	54	34	M16x50	5/8x2"	4437	5,98
34	5"	DFS118S (*)	142,0	120	152,40	184	92,08	180	100	56	28	M16x50	5/8x2"	4537	8,12

**SERIE 6000**

414	1/2"	DFS401S012	21,6	13	40,49	57	18,24	46	72	32	19	M8x30	5/16x1"1/4	4075	0,57
414	1/2"	DFS401S038	17,5	13	40,49	57	18,24	46	72	32	19	M8x30	5/16x1"1/4	4075	0,62
414	3/4"	DFS402S	27,2	19	50,80	71	23,80	55	70	42	22	M10x40	3/8x1"1/2	4100	1,14
414	1"	DFS403S	34,0	25	57,15	81	27,76	65	84	50	22	M12x45	7/16x1"3/4	4131	1,76
414	1"1/4	DFS404S	42,8	32	66,68	95	31,75	78	90	54	25	M14x45	1/2x1"3/4	4150	2,62
414	1"1/2	DFS405S	48,6	38	79,38	112	36,50	94	100	60	28	M16x50	5/8x2"	4187	4,23
414	2"	DFS406S	61,0	51	96,82	134	44,45	114	130	74	24	M20x70	3/4x2"1/2	4225	7,63
414	2"1/2	DFS507S (*)	76,6	63	123,80	180	58,70	152	160	90	30	M24x80	-	4275	-
414	3"	DFS508S (*)	90,5	73	152,40	208	71,40	178	180	110	30	M30x100	-	4337	-

**DESIGNAZIONE PER ORDINE  
DESIGNATION FOR ORDER**

**Materiale / Material**

**ST52.3**      **AISI 316L**

Flangia + controflangia + set viti metriche  
Flange + counter-flange + metric screws set

**DFS...SM**      **DFX...SM**

Flangia + controflangia + set viti unc  
Flange + counter-flange + unc screws set

**DFS...SU**      **DFX...SU**

**NOTE / NOTES**

- (•) Solo in ST52.3
- (•) Only in ST52.3

set viti unc disponibili solo in acciaio al carbonio.  
unc screws set available only in carbon steel.

(\*) set viti disponibili solo in acciaio al carbonio.  
(\*) screws set available only in carbon steel.



# DOPPIE FLANGE FILETTATE GAS E A SALDARE DI TASCA

## BSP THREADED AND WELD IN DOUBLE FLANGES

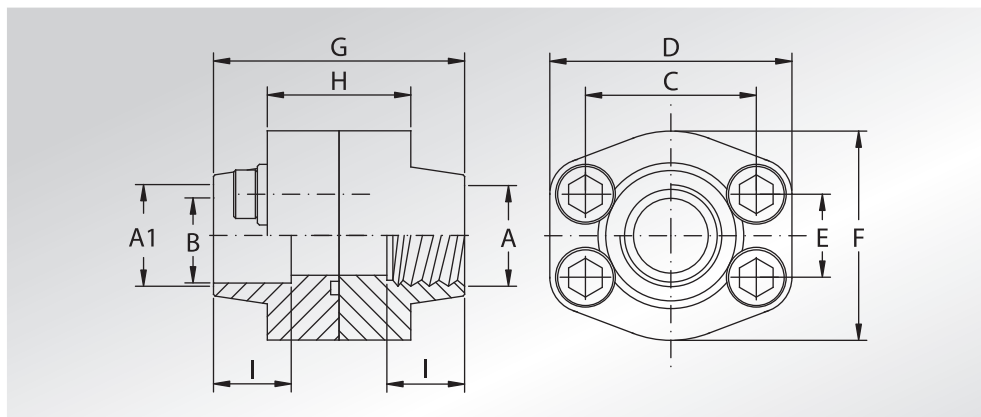

Pressione max di esercizio raccomandata Kg/cm <sup>2</sup>	Grandezza	Tipo	Dimensioni										Viti		Or tipo	Peso Kg
Maximum recommended working pressure Kg/cm <sup>2</sup>	Size	Type	Dimensions										Screws		Or type	Weight Kg
			A	A1	B	C	D	E	F	G	H	I	Metric	Unc		

### SERIE 3000

345	1/2"	DFS080F	1/2" GAS	21,6	13	38,10	57	17,48	46	72	32	19	M8x30	5/16x1"1/4	4075	0,57
345	1/2"	DFS080F038	3/8" GAS	17,5	13	38,10	57	17,48	46	72	32	19	M8x30	5/16x1"1/4	4075	0,61
345	3/4"	DFS100F	3/4" GAS	27,2	19	47,63	65	22,23	50	72	36	19	M10x35	3/8x1"1/2	4100	0,90
345	1"	DFS102F	1" GAS	34,0	25	52,37	70	26,19	55	76	36	19	M10x35	3/8x1"1/2	4131	1,06
276	1"1/4	DFS104F	1"1/4 GAS	42,8	32	58,72	79	30,18	68	82	42	22	M10x40	7/16x1"3/4	4150	1,50
207	1"1/2	DFS106F	1"1/2 GAS	48,6	38	69,85	93	35,71	78	90	50	24	M12x45	1/2x1"3/4	4187	2,36
207	2"	DFS108F	2" GAS	61,0	51	77,77	102	42,88	90	90	50	26/30	M12x45	1/2x1"3/4	4225	2,61
172	2"1/2	DFS110F	2"1/2 GAS	76,6	63	88,90	114	50,80	105	100	50	30	M12x45	1/2x1"3/4	4275	3,40
138	3"	DFS112F	3" GAS	90,5	73	106,38	134	61,93	124	100	54	34	M16x50	5/8x2"	4337	4,89
34	3"1/2	DFS114F	3"1/2 GAS	103,0	89	120,65	152	69,85	136	96	54	34	M16x50	5/8x2"	4387	5,29
34	4"	DFS116F	4" GAS	115,5	99	130,18	162	77,77	146	96	54	34	M16x50	5/8x2"	4437	6,00
34	5"	DFS118F (*)	5" GAS	142,0	120	152,40	184	92,08	180	100	56	28/30	M16x50	5/8x2"	4537	8,12

### SERIE 6000

414	1/2"	DFS401F012	1/2" GAS	21,6	13	40,49	57	18,24	46	72	32	19	M8x30	5/16x1"1/4	4075	0,57
414	1/2"	DFS401F038	3/8" GAS	17,5	13	40,49	57	18,24	46	72	32	19	M8x30	5/16x1"1/4	4075	0,62
414	3/4"	DFS402F	3/4" GAS	27,2	19	50,80	71	23,80	55	70	42	22	M10x40	3/8x1"1/2	4100	1,19
414	1"	DFS403F	1" GAS	34,0	25	57,15	81	27,76	65	84	50	22	M12x45	7/16x1"3/4	4131	1,88
414	1"1/4	DFS404F	1"1/4 GAS	42,8	32	66,68	95	31,75	78	90	54	25	M14x45	1/2x1"3/4	4150	2,63
414	1"1/2	DFS405F	1"1/2 GAS	48,6	38	79,38	112	36,50	94	100	60	28	M16x50	5/8x2"	4187	4,19
414	2"	DFS406F	2" GAS	61,0	51	96,82	134	44,45	114	130	74	24/30	M20x70	3/4x2"1/2	4225	7,64
414	2"1/2	DFS507F (*)	2"1/2 GAS	76,6	63	123,80	180	58,70	152	160	90	32	M24x80	-	4275	-
414	3"	DFS508F (*)	3" GAS	90,5	73	152,40	208	71,40	178	180	110	30/40	M30x100	-	4337	-

#### DESIGNAZIONE PER ORDINE DESIGNATION FOR ORDER

Flangia a saldare di tasca + controflangia filettata gas + set viti metriche  
Weld in flange + BSP threaded counter-flange + metric screws set

#### Materiale / Material

ST52.3      AISI 316L

DFS...FM      DFX...FM

Flangia a saldare di tasca + controflangia filettata gas + set viti unc  
Weld in flange + BSP threaded counter-flange + unc screws set

DFS...FU      DFX...FU

#### NOTE / NOTES

\* Per viti unc L=13,5  
\* For unc screws L=13,5

(●) Solo in ST52.3  
(●) Only in ST52.3

set viti unc disponibili solo in acciaio al carbonio.  
unc screws set available only in carbon steel.

(\*) set viti disponibili solo in acciaio al carbonio.  
(\*) screws set available only in carbon steel.

# FLANGE A 90° A SALDARE DI TASCA



## WELD IN 90° FLANGES

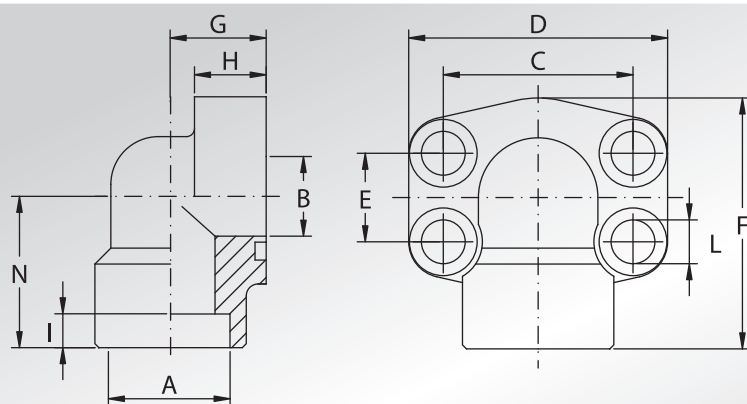

Pressione max di esercizio raccomandata Kg/cm <sup>2</sup>	Grandezza	Tipo	Dimensioni										Viti		Or tipo	Peso Kg	
Maximum recommended working pressure Kg/cm <sup>2</sup>	Size	Type	Dimensions										Screws		Or type	Weight Kg	
			A	B	C	D	E	F	G	H	I	L	N	Metric	Unc		

### SERIE 3000

345	1/2"	AFS08090S	21,6	13	38,10	54	17,48	60	20	16	10	9	37	M8x30	5/16x1"1/4	4075	0,28
345	1/2"	AFS08090S038	17,5	13	38,10	54	17,48	60	20	16	10	9	37	M8x30	5/16x1"1/4	4075	0,29
345	3/4"	AFS10090S	27,2	19	47,63	65	22,23	63	24	18	10	11	38	M10x35	3/8x1"1/2	4100	0,45
345	1"	AFS10290S	34,0	25	52,37	70	26,19	70	28	19	12	11	43	M10x35	3/8x1"1/2	4131	0,56
276	1"1/4	AFS10490S	42,8	32	58,72	79	30,18	85	34	21	14	11,5	51	M10x40	7/16x1"3/4	4150	0,89
207	1"1/2	AFS10690S	48,6	38	69,85	93	35,71	95	38	25	16	13,5	56	M12x45	1/2x1"3/4	4187	1,18
207	2"	AFS10890S	61,0	51	77,77	110	42,88	110	42	25	18	13,5	65	M12x45	1/2x1"3/4	4225	2,06

### SERIE 6000

414	1/2"	AFS40190S012	21,6	13	40,49	54	18,24	60	20	16	10	9	37	M8x30	5/16x1"1/4	4075	0,28
414	1/2"	AFS40190S038	17,5	13	40,49	54	18,24	60	20	16	10	9	37	M8x30	5/16x1"1/4	4075	0,29
414	3/4"	AFS40290S	27,2	19	50,80	70	23,80	70	28	19	12	11	43	M10x40	3/8x1"1/2	4100	0,69
414	1"	AFS40390S	34,0	25	57,15	79	27,76	85	34	21	14	13	51	M12x45	7/16x1"3/4	4131	1,11
414	1"1/4	AFS40490S	42,8	32	66,68	93	31,75	95	38	25	16	15 *	56	M14x45	1/2x1"3/4	4150	1,45
414	1"1/2	AFS40590S	48,6	38	79,38	110	36,50	110	42	25	18	17	65	M16x50	5/8x2"	4187	2,75
414	2"	AFS40690S	61,0	51	96,82	134	44,45	132	45	35	25	21	75	M20x70	3/4x2"1/2	4225	3,85

#### DESIGNAZIONE PER ORDINE DESIGNATION FOR ORDER

#### Materiale / Material

ST52.3      AISI 316L

Solo flangia  
Only flange

**AFS...90S**      **AFX...90S**

Flangia completa di viti metriche, grower e o-ring  
Flange complete of metric screws, grower type washers and o-ring

**AFS...90SM**      **AFX...90SM**

Flangia completa di viti unc, grower e o-ring  
Flange complete of unc screws, grower type washers and o-ring

**AFS...90SU**      **AFX...90SU**

#### NOTE / NOTES

\* Per viti unc L=13,5  
\* For unc screws L=13,5

set viti unc disponibili solo in acciaio al carbonio.  
unc screws set available only in carbon steel.



# FLANGE A 90° A SALDARE DI TASCA TUBO METRICO

## METRIC PIPE WELD IN 90° FLANGES

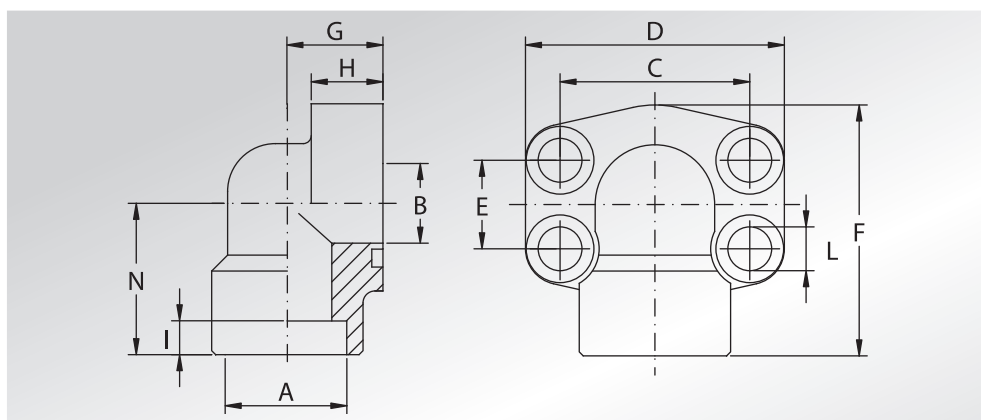

Pressione max di esercizio raccomandata Kg/cm <sup>2</sup>	Grandezza	Tipo	Dimensioni											Viti		Or tipo	Peso Kg
Maximum recommended working pressure Kg/cm <sup>2</sup>	Size	Type	Dimensions											Screws		Or type	Weight Kg
			A	B	C	D	E	F	G	H	I	L	N	Metric	Unc		

### SERIE 3000

345	1/2"	AFS08090SA20	20,3	13	38,10	54	17,48	60	20	16	10	9	37	M8x30	5/16x1"1/4	4075	0,28
345	3/4"	AFS10090SA25	25,3	19	47,63	65	22,23	63	24	18	10	11	38	M10x35	3/8x1"1/2	4100	0,45
345	1"	AFS10290SA30	30,3	25	52,37	70	26,19	70	28	19	12	11	43	M10x35	3/8x1"1/2	4131	0,56
276	1"1/4	AFS10490SA38	38,3	32	58,72	79	30,18	85	34	21	14	11,5	51	M10x40	7/16x1"3/4	4150	0,89
207	1"1/2	AFS10690SA50	50,5	38	69,85	93	35,71	95	38	25	16	13,5	56	M12x45	1/2x1"3/4	4187	1,18

### SERIE 6000

414	1/2"	AFS40190SA20	20,3	13	40,49	54	18,24	60	20	16	10	9	37	M8x30	5/16x1"1/4	4075	0,28
414	3/4"	AFS40290SA25	25,3	19	50,80	70	23,80	70	28	19	12	11	43	M10x40	3/8x1"1/2	4100	0,69
414	1"	AFS40390SA30	30,3	25	57,15	79	27,76	85	34	21	14	13	51	M12x45	7/16x1"3/4	4131	1,11
414	1"1/4	AFS40490SA38	38,3	32	66,68	93	31,75	95	38	25	16	15 *	56	M14x45	1/2x1"3/4	4150	1,45
414	1"1/2	AFS40590SA50	50,5	38	79,38	110	36,50	110	42	25	18	17	65	M16x50	5/8x2"	4187	2,75

DESIGNAZIONE PER ORDINE DESIGNATION FOR ORDER	Materiale / Material	
	ST52.3	AISI 316L
Solo flangia Only flange	<b>AFS...90SA</b>	<b>AFX...90SA</b>
Flangia completa di viti metriche, grower e o-ring Flange complete of metric screws, grower type washers and o-ring	<b>AFS...90SA...M</b>	<b>AFX...90SA...M</b>
Flangia completa di viti unc, grower e o-ring Flange complete of unc screws, grower type washers and o-ring	<b>AFS...90SA...U</b>	<b>AFX...90SA...U</b>

### NOTE / NOTES

\* Per viti unc L=13,5  
\* For unc screws L=13,5

set viti unc disponibili solo in acciaio al carbonio.  
unc screws set available only in carbon steel.

**CONTROFLANGE  
A 90° A SILDARE  
DI TASCA**



**WELD IN 90°  
COUNTER-FLANGES**

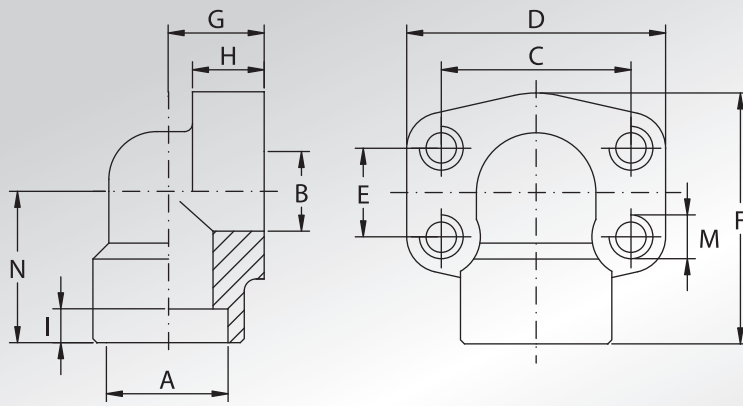

Pressione max di esercizio raccomandata Kg/cm <sup>2</sup>	Grandezza	Tipo	Dimensioni											Peso Kg
			Dimensions											
Maximum recommended working pressure Kg/cm <sup>2</sup>	Size	Type	A	B	C	D	E	F	G	H	I	M	N	Weight Kg
			<b>SERIE 3000</b>											
345	1/2"	GFS08090S	21,6	13	38,10	54	17,48	60	20	16	10	M8	37	0,28
345	1/2"	GFS08090S038	17,5	13	38,10	54	17,48	60	20	16	10	M8	37	0,29
345	3/4"	GFS10090S	27,2	19	47,63	65	22,23	63	24	18	10	M10	38	0,45
345	1"	GFS10290S	34,0	25	52,37	70	26,19	70	28	19	12	M10	43	0,56
276	1"1/4	GFS10490S	42,8	32	58,72	79	30,18	85	34	21	14	M10	51	0,89
207	1"1/2	GFS10690S	48,6	38	69,85	93	35,71	95	38	25	16	M12	56	1,18
207	2"	GFS10890S	61,0	51	77,77	110	42,88	110	42	25	18	M12	65	2,06
<b>SERIE 6000</b>														
414	1/2"	GFS40190S012	21,6	13	40,49	54	18,24	60	20	16	10	M8	37	0,28
414	1/2"	GFS40190S038	17,5	13	40,49	54	18,24	60	20	16	10	M8	37	0,29
414	3/4"	GFS40290S	27,2	19	50,80	70	23,80	70	28	19	12	M10	43	0,69
414	1"	GFS40390S	34,0	25	57,15	79	27,76	85	34	21	14	M12	51	1,11
414	1"1/4	GFS40490S	42,8	32	66,68	93	31,75	95	38	25	16	M14	56	1,45
414	1"1/2	GFS40590S	48,6	38	79,38	110	36,50	110	42	25	18	M16	65	2,75
414	2"	GFS40690S	61,0	51	96,82	134	44,45	132	45	35	25	M20	75	3,85

**DESIGNAZIONE PER ORDINE  
DESIGNATION FOR ORDER**

**Materiale / Material**

**NOTE / NOTES**

**ST52.3**

**AISI 316L**

Controflangia con fori di fissaggio filettati metrici  
Counter-flange with metric threaded fixing holes

**GFS...90S**

**GFX...90S**



## FLANGE A 90° A SALDARE DI TASCA

## WELD IN 90° FLANGES

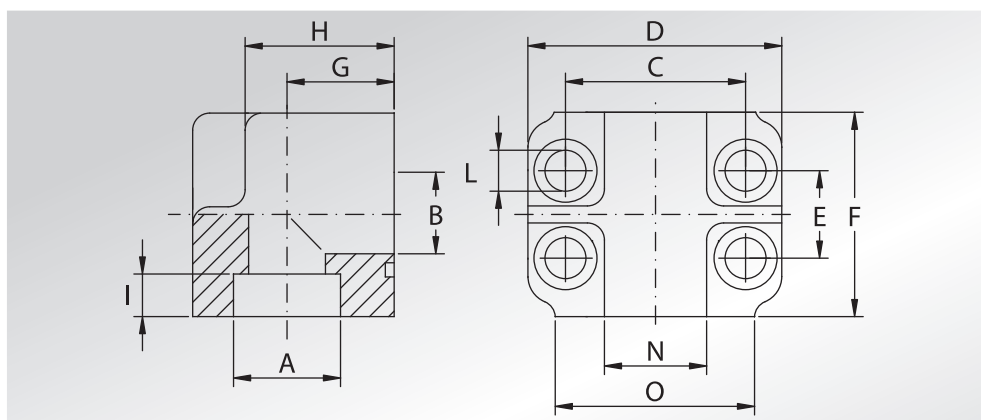

Pressione max di esercizio raccomandata Kg/cm <sup>2</sup>	Grandezza	Tipo	Dimensioni										Viti	Or tipo	Peso Kg		
Maximum recommended working pressure Kg/cm <sup>2</sup>	Size	Type	Dimensions										Screws	Or type	Weight Kg		
			A	B	C	D	E	F	G	H	I	L	N	O	Metric		

### SERIE 3000

345	3/4"	AFS20090S	27,2	19	47,63	66	22,23	46	19	27	5	11	28	48	M10x45	4100	0,52
345	1"	AFS20290S	34,0	25	52,37	71	26,19	55	22	34	6	11	32	50	M10x50	4131	0,87
276	1"1/4	AFS20490S	42,8	32	58,72	81	30,18	65	27	42	7	11,5	35	60	M10x60	4150	1,35
207	1"1/2	AFS20690S	48,6	38	69,85	95	35,71	75	32	50	8	13,5	42	70	M12x70	4187	2,15
207	2"	AFS20890S	61,0	51	77,77	112	42,88	90	40	63	10	13,5	50	80	M12x80	4225	3,70
172	2"1/2	AFS21090S *	76,6	63	88,90	120	50,80	120	53	99	15	13,5	-	-	-	4275	8,20

### SERIE 6000

414	3/4"	AFS70090S	27,2	19	50,80	71	23,80	55	22	34	6	11	32	50	M10x50	4100	0,97
414	1"	AFS70290S	34,0	25	57,15	81	27,76	65	27	42	7	13	35	60	M12x60	4131	1,50
414	1"1/4	AFS70490S	42,8	32	66,68	95	31,75	75	32	50	8	15	42	70	M14x70	4150	2,29
414	1"1/2	AFS70690S	48,6	38	79,38	112	36,50	90	40	63	10	17	50	80	M16x90	4187	4,08

#### DESIGNAZIONE PER ORDINE DESIGNATION FOR ORDER

Solo flangia  
Only flange

Flangia completa di viti metriche, grower e o-ring  
Flange complete of metric screws, grower type washers and o-ring

#### Materiale / Material

ST52.3

AFS...90S

AFS...90SM

#### NOTE / NOTES

- \* Ricavata da barra
- \* Obtained from bar



**FLANGE PIATTE  
A SILDARE  
DI TASCA**



**WELD IN FLAT  
FLANGES**

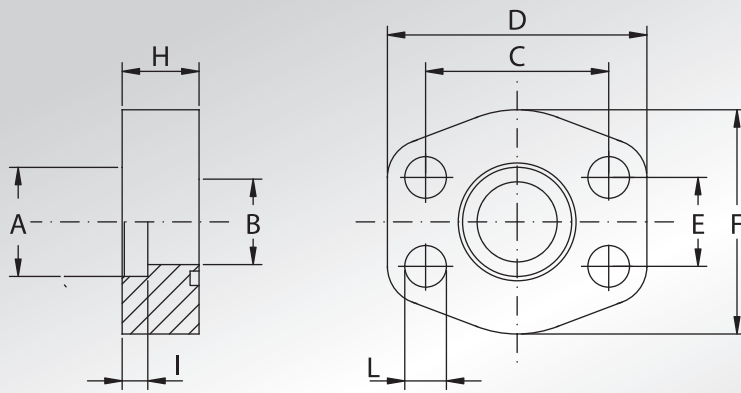

Pressione max di esercizio raccomandata Kg/cm <sup>2</sup>	Grandezza	Tipo	Dimensioni										Viti	Or tipo	Peso Kg	
			Dimensions													Screws
Maximum recommended working pressure Kg/cm <sup>2</sup>	Size	Type	A	B	C	D	E	F	H	I	L	Metric				
<b>SERIE 3000</b>																
40	1/2"	AFC080S	22,5	15	38,10	56	17,48	46	14	3	9	M8x25	4075	0,12		
40	3/4"	AFC100S	28,5	20	47,63	65	22,23	50	12	4	11	M10x30	4100	0,20		
40	1"	AFC102S	35,5	29	52,37	70	26,19	55	12	4	11	M10x30	4131	0,25		
40	1"1/4	AFC104S	42,5	34	58,72	79	30,18	68	12	4	11,5	M10x30	4150	0,28		
40	1"1/2	AFC106S	49,0	42	69,85	93	35,71	78	15	4	13,5	M12x35	4187	0,50		
40	2"	AFC108S	61,0	53	77,77	102	42,88	90	15	4	13,5	M12x35	4225	0,59		
40	2"1/2	AFC110S	77,0	64	88,90	114	50,80	105	15	4	13,5	M12x35	4275	0,72		
40	3"	AFC112S	90,0	80	106,38	134	61,93	124	20	5	17,5	M16x50	4337	1,25		
40	3"1/2	AFC114S	103,0	93	120,65	152	69,85	136	20	5	17,5	M16x50	4387	1,50		
40	4"	AFC116S	116,0	105	130,18	162	77,77	146	25	6	17,5	M16x50	4437	2,15		
40	5"	AFC118S	141,0	126	152,40	190	92,08	170	28	8	17,5	M16x50	4537	3,00		

DESIGNAZIONE PER ORDINE DESIGNATION FOR ORDER	Materiale / Material	
	ST52.3	AISI 316L
Solo flangia Only flange	<b>AFC...S</b>	<b>AFCX...S</b>
Flangia completa di viti metriche, grower e o-ring Flange complete of metric screws, grower type washers and o-ring	<b>AFC...SM</b>	<b>AFCX...SM</b>

**NOTE / NOTES**



## CONTROFLANGE PIATTE A SALDARE DI TASCA

## WELD IN FLAT COUNTER-FLANGES

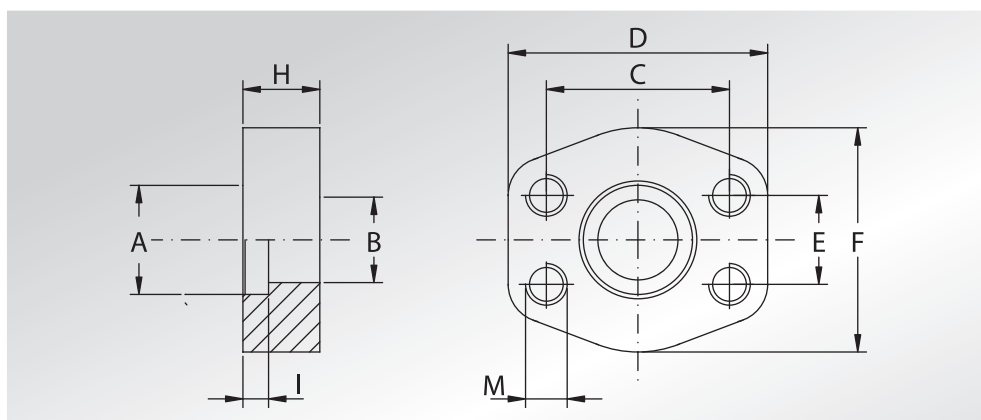

Pressione max di esercizio raccomandata Kg/cm <sup>2</sup>	Grandezza	Tipo	Dimensioni										Peso Kg	
Maximum recommended working pressure Kg/cm <sup>2</sup>	Size	Type	Dimensions										Weight Kg	
			A	B	C	D	E	F	H	I	M			
<b>SERIE 3000</b>														
												Metric	Unc	
40	1/2"	GFC080S	22,5	15	38,10	56	17,48	46	14	3	M8	5/16	0,12	
40	3/4"	GFC100S	28,5	20	47,63	65	22,23	50	12	4	M10	3/8	0,20	
40	1"	GFC102S	35,5	29	52,37	70	26,19	55	12	4	M10	3/8	0,25	
40	1"1/4	GFC104S	42,5	34	58,72	79	30,18	68	12	4	M10	7/16	0,28	
40	1"1/2	GFC106S	49,0	42	69,85	93	35,71	78	15	4	M12	1/2	0,50	
40	2"	GFC108S	61,0	53	77,77	102	42,88	90	15	4	M12	1/2	0,59	
40	2"1/2	GFC110S	77,0	64	88,90	114	50,80	105	15	4	M12	1/2	0,72	
40	3"	GFC112S	90,0	80	106,38	134	61,93	124	20	5	M16	5/8	1,25	
40	3"1/2	GFC114S	103,0	93	120,65	152	69,85	136	20	5	M16	5/8	1,50	
40	4"	GFC116S	116,0	105	130,18	162	77,77	146	25	6	M16	5/8	2,15	
40	5"	GFC118S	141,0	126	152,40	190	92,08	170	28	8	M16	5/8	3,00	

### DESIGNAZIONE PER ORDINE DESIGNATION FOR ORDER

Controflangia con fori di fissaggio filettati metrici  
Counter-flange with metric threaded fixing holes

**GFC...S**

**GFCX...S**

Controflangia con fori di fissaggio filettati unc  
Counter-flange with unc threaded fixing holes

**GFC...SU**

**GFCX...SU**

### NOTE / NOTES

**FLANGE PIATTE  
A SALDARE  
DI TASCA**



**WELD IN FLAT  
FLANGES**

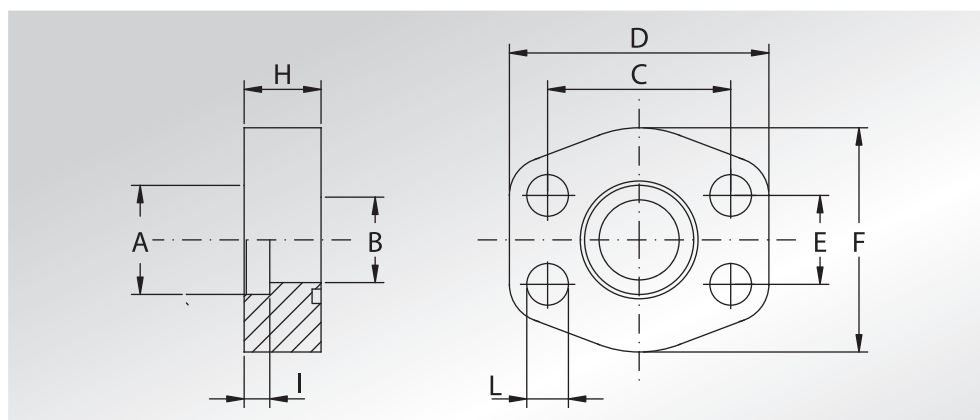

Pressione max di esercizio raccomandata Kg/cm <sup>2</sup>	Grandezza	Tipo	Dimensioni									Viti	Or tipo	Peso Kg
			Dimensions											
Maximum recommended working pressure Kg/cm <sup>2</sup>	Size	Type	A	B	C	D	E	F	H	I	L	Metric		
<b>SERIE 3000</b>														
40	1/2"	PFS080	21,5	14	38,10	56	17,48	46	14	3	9	M8x25	4075	0,12
40	3/4"	PFS100	27,2	19	47,63	65	22,23	50	12,5	3	11	M10x30	4100	0,20
40	1"	PFS102	34,0	25	52,37	70	26,19	55	12,5	3	11	M10x30	4131	0,25
40	1"1/4	PFS104	42,8	32	58,72	79	30,18	68	12,5	3	11,5	M10x30	4150	0,28
40	1"1/2	PFS106	48,6	38	69,85	93	35,71	78	15	3	13,5	M12x35	4187	0,50
40	2"	PFS108	61,0	51	77,77	102	42,88	90	15	5	13,5	M12x35	4225	0,50

DESIGNAZIONE PER ORDINE DESIGNATION FOR ORDER	Materiale / Material	
	ST52.3	AISI 316L
Solo flangia Only flange	<b>PFS...</b>	<b>PFX...</b>
Flangia completa di viti metriche, grower e o-ring Flange complete of metric screws, grower type washers and o-ring	<b>PFS...M</b>	<b>PFX...M</b>

**NOTE / NOTES**



## FLANGE PIATTE CON TASCA

## POCKET FLAT FLANGES

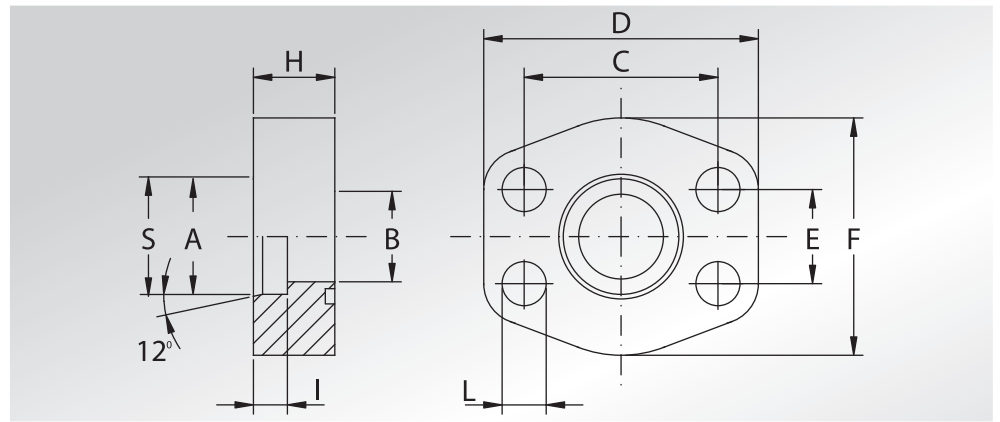

Pressione max di esercizio raccomandata Kg/cm <sup>2</sup>	Grandezza	Tipo	Dimensioni										Peso Kg
Maximum recommended working pressure Kg/cm <sup>2</sup>	Size	Type	Dimensions										Weight Kg
			A	B	C	D	E	F	H	I	L	S	

### SERIE 6000

414	1/2"	PFS401SP17	17	14	40,49	56	18,24	48	14	9	9	19,5	0,20
414	1/2"	PFS401SP22	22	16	40,49	56	18,24	48	14	9	9	24,0	0,20
414	3/4"	PFS402SP	27	20	50,80	71	23,80	60	18	9	11	29,5	0,40
414	1"	PFS403SP	34	26	57,15	81	27,76	70	22	13	14	36,0	0,80
414	1"1/4	PFS404SP	43	32	66,68	95	31,75	78	25	15,5	16	46,0	1,00



## FLANGE PIATTE CON FORO PASSANTE

## FLAT FLANGES WITH THROUGH HOLE

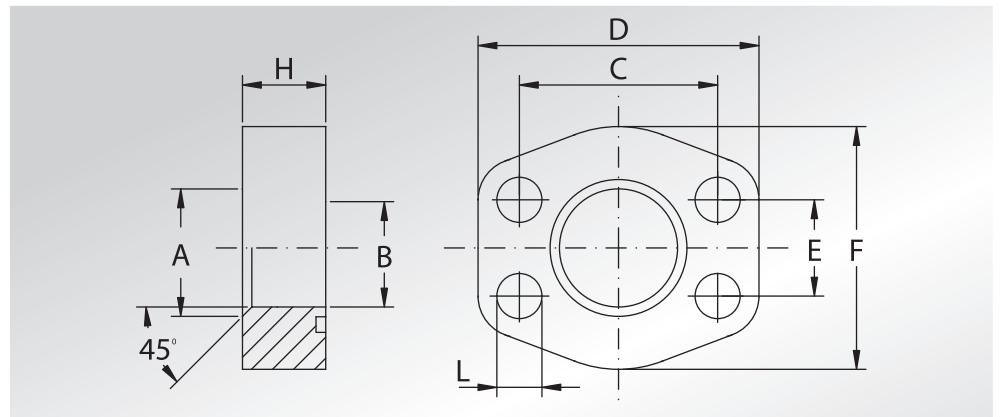

Pressione max di esercizio raccomandata Kg/cm <sup>2</sup>	Grandezza	Tipo	Dimensioni										Peso Kg
Maximum recommended working pressure Kg/cm <sup>2</sup>	Size	Type	Dimensions										Weight Kg
			A	B	C	D	E	F	H	L			

### SERIE 6000

414	1/2"	PFS401P20	22	20,5	40,49	56	18,24	48	14	9	9	0,20
414	1/2"	PFS401P24	27	24	40,49	56	18,24	48	14	9	9	0,20
414	3/4"	PFS402P	32	28,5	50,80	71	23,80	60	18	11	11	0,40
414	1"	PFS403P	43	37,5	57,15	81	27,76	70	22	14	14	0,80
414	1"1/4	PFS404P	49	44	66,68	95	31,75	78	25	16	16	1,00

### DESIGNAZIONE PER ORDINE DESIGNATION FOR ORDER

Solo flangia  
Only flange

### Materiale / Material

ST52.3      AISI 316L

PFS...

PFX...

### NOTE / NOTES

**DISTANZIALE SAE  
CON FORO  
LATERALE**



**SAE DISTANCE  
PIECE WITH  
LATERAL HOLE**

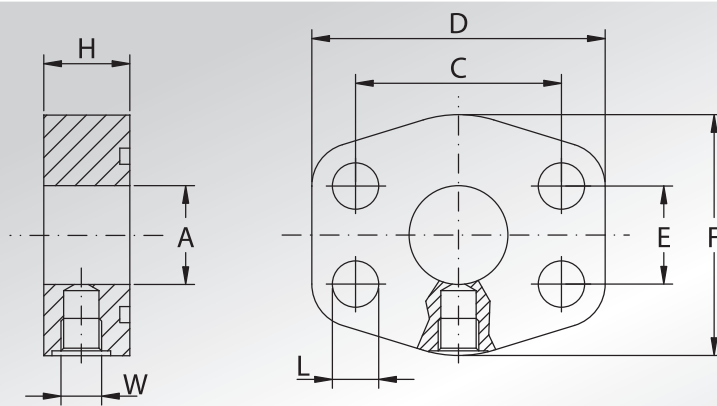

Pressione max di esercizio raccomandata Kg/cm <sup>2</sup>	Grandezza	Tipo	Dimensioni								Or tipo	Peso Kg
Maximum recommended working pressure Kg/cm <sup>2</sup>	Size	Type	Dimensions								Or type	Weight Kg
			A	C	D	E	F	H	L	W		

**SERIE 3000**

345	1"	D102	25,0	52,37	71	26,19	60	19	11	M10 - G1/8	4131	0,35
276	1"1/4	D104	32	58,72	81	30,18	68	20	11,5	M10 - M12 - G1/8 - G1/4	4150	0,45
207	1"1/2	D106	38	69,85	95	35,71	78	25	13,5	M10 - M12 - G1/8 - G1/4	4187	0,69
207	2"	D108	51	77,77	102	42,88	90	19	13,5	M10 - G1/8	4225	0,78
172	2"1/2	D110	63	88,90	114	50,80	105	19	13,5	M10 - G1/8	4275	0,94
138	3"	D112	73	106,38	134	61,93	124	23	17,5	M10 - M12 - G1/8 - G1/4	4337	1,63

**SERIE 6000**

414	3/4"	D402	19	50,80	71	23,80	60	19	11	M10 - G1/8	4100	0,40
414	1"	D403	25	57,15	81	27,76	70	22	13	M10 - M12 - G1/8 - G1/4	4131	0,70
414	1"1/4	D404	32	66,68	95	31,75	78	25	15	M10 - M12 - G1/8 - G1/4	4150	1,00
414	1"1/2	D405	38	79,38	112	36,50	94	28	17	M10 - M12 - G1/8 - G1/4	4187	1,55
414	2"	D406	51	96,82	134	44,45	114	28	21	M10 - M12 - G1/8 - G1/4	4225	2,57

**DESIGNAZIONE PER ORDINE  
DESIGNATION FOR ORDER**

**Materiale / Material**

**NOTE / NOTES**

**ST52.3**

**AISI 316L**

Distanziale con foro metrico  
Distance piece with metric hole

**D...M...**

**DX...M...**

Distanziale con foro gas  
Distance piece with BSP hole

**D...G...**

**DX...G...**



# FLANGE A SALDARE DI TESTA SCH.80

## WELD ON FLANGES SCH.80

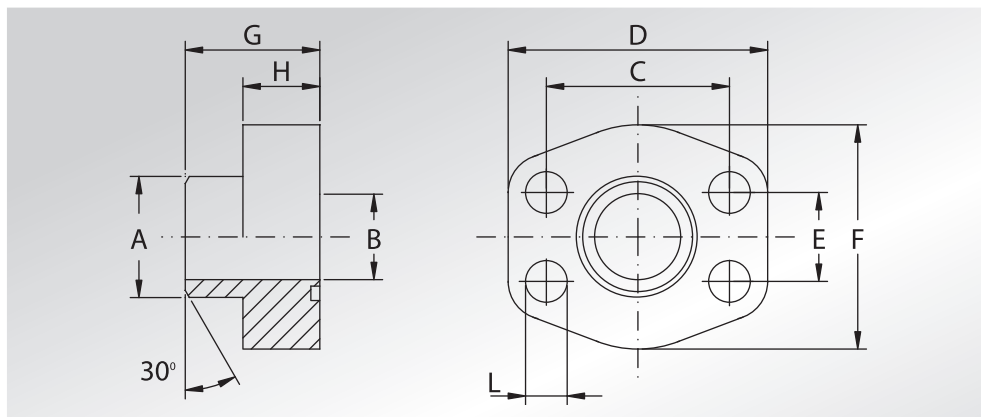

Pressione max di esercizio raccomandata Kg/cm <sup>2</sup>	Grandezza	Tipo	Dimensioni									Viti		Or tipo	Peso Kg
Maximum recommended working pressure Kg/cm <sup>2</sup>	Size	Type	Dimensions									Screws		Or type	Weight Kg
			A	B	C	D	E	F	G	H	L	Metric	Unc		

### SERIE 3000

345	1/2"	AFS080ST	21,5	13	38,10	57	17,48	46	36	16	9	M8x30	5/16x1"1/4	4075	0,24
345	1/2"	AFS080ST038	17,5	13	38,10	57	17,48	46	36	16	9	M8x30	5/16x1"1/4	4075	0,22
345	3/4"	AFS100ST	28,0	19	47,63	65	22,23	50	36	18	11	M10x35	3/8x1"1/2	4100	0,35
345	1"	AFS102ST	34,0	25	52,37	70	26,19	55	38	18	11	M10x35	3/8x1"1/2	4131	0,41
276	1"1/4	AFS104ST	42,8	32	58,72	79	30,18	68	41	21	11,5	M10x40	7/16x1"3/4	4150	0,64
207	1"1/2	AFS106ST	48,6	38	69,85	93	35,71	78	44	25	13,5	M12x45	1/2x1"3/4	4187	0,98
207	2"	AFS108ST	61,0	51	77,77	102	42,88	90	45	25	13,5	M12x45	1/2x1"3/4	4225	1,14
172	2"1/2	AFS110ST	77,0	63	88,90	114	50,80	105	50	25	13,5	M12x45	1/2x1"3/4	4275	1,55
138	3"	AFS112ST	92,0	73	106,38	134	61,93	124	50	27	17,5	M16x50	5/8x2"	4337	2,33
34	3"1/2	AFS114ST	103,0	89	120,65	152	69,85	136	48	27	17,5	M16x50	5/8x2"	4387	2,40
34	4"	AFS116ST	115,5	99	130,18	162	77,77	146	48	27	17,5	M16x50	5/8x2"	4437	2,85
34	5"	AFS118ST (•)	140,2	120	152,40	184	92,08	180	50	28	17,5	M16x50	5/8x2"	4537	3,60

### SERIE 6000

414	1/2"	AFS401ST012	21,5	13	40,49	57	18,24	46	36	16	9	M8x30	5/16x1"1/4	4075	0,24
414	1/2"	AFS401ST038	17,5	13	40,49	57	18,24	46	36	16	9	M8x30	5/16x1"1/4	4075	0,22
414	3/4"	AFS402ST	28,0	19	50,80	71	23,80	55	35	21	11	M10x40	3/8x1"1/2	4100	0,48
414	1"	AFS403ST	34,0	25	57,15	79	27,76	68	41	21	13	M12x45	7/16x1"3/4	4131	0,64
375	1"1/4	AFS404ST	42,8	32	66,68	93	31,75	78	44	25	15 *	M14x45	1/2x1"3/4	4150	1,00
320	1"1/2	AFS405ST	48,6	38	79,38	112	36,50	94	55	30	17	M16x50	5/8x2"	4187	1,68
250	2"	AFS406ST	61,0	51	96,82	134	44,45	114	65	37	21	M20x70	3/4x2"1/2	4225	2,86
230	2"1/2	AFS507ST	76,6	63	123,80	180	58,70	152	80	45	26	M24x80	-	4275	6,40
200	3"	AFS508ST	90,0	73	152,40	208	71,40	178	90	55	33	M30x100	-	4337	-

PER QUESTA TIPOLOGIA DI PRODOTTO, VERIFICATE SEMPRE SE LA QUOTA "A" E "B" CORRISPONDE ALLA SCHEDULA DEL VOSTRO TUBO

FOR THIS KIND OF PRODUCT, PLEASE ALWAYS VERIFY IF DIMENSION "A" AND "B" CORRESPOND TO THE SCHEDULE OF YOUR TUBE

DESIGNAZIONE PER ORDINE DESIGNATION FOR ORDER	Materiale / Material	
	ST52.3	AISI 316L
Solo flangia Only flange	<b>AFS...ST</b>	<b>AFX...ST</b>
Flangia completa di viti metriche, grower e o-ring Flange complete of metric screws, grower type washers and o-ring	<b>AFS...STM</b>	<b>AFX...STM</b>
Flangia completa di viti unc, grower e o-ring Flange complete of unc screws, grower type washers and o-ring	<b>AFS...STU</b>	<b>AFX...STU</b>

#### NOTE / NOTES

\* Per viti unc L=13,5  
\* For unc screws L=13,5

(•) Solo in ST52.3  
(•) Only in ST52.3

set viti unc disponibili solo in acciaio al carbonio.  
unc screws set available only in carbon steel.

# FLANGE A SALDARE DI TESTA SCH.160



## WELD ON FLANGES SCH.160

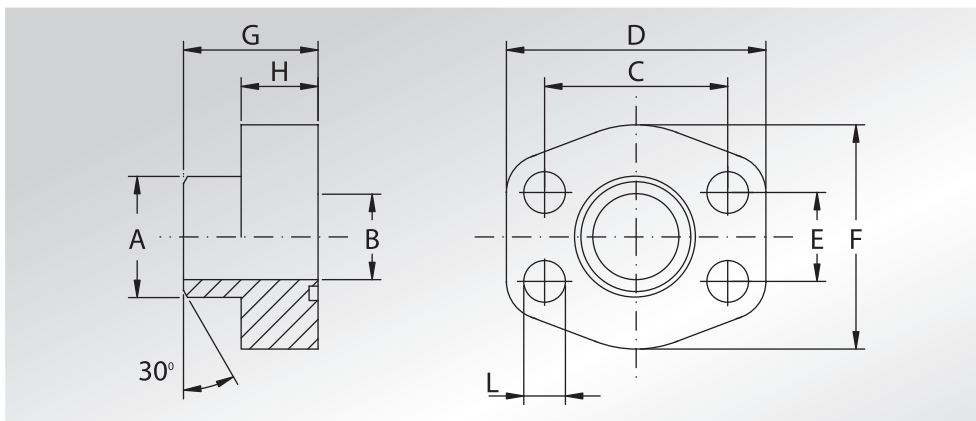

Pressione max di esercizio raccomandata Kg/cm <sup>2</sup>	Grandezza	Tipo	Dimensioni									Viti		Or tipo	Peso Kg
Maximum recommended working pressure Kg/cm <sup>2</sup>	Size	Type	Dimensions									Screws		Or type	Weight Kg
			A	B	C	D	E	F	G	H	L	Metric	Unc		

### SERIE 3000

345	1/2"	AFS080STB11	21,5	11,8	38,10	57	17,48	46	36	16	9	M8x30	5/16x1"1/4	4075	0,24
345	3/4"	AFS100STB15	28,0	15,6	47,63	65	22,23	50	36	18	11	M10x35	3/8x1"1/2	4100	0,35
345	1"	AFS102STB20	34,0	20,7	52,37	70	26,19	55	38	18	11	M10x35	3/8x1"1/2	4131	0,41
276	1"1/4	AFS104STB29	42,8	29,5	58,72	79	30,18	68	41	21	11,5	M10x40	7/16x1"3/4	4150	0,64
207	1"1/2	AFS106STB34	48,6	34	69,85	93	35,71	78	44	25	13,5	M12x45	1/2x1"3/4	4187	0,98
207	2"	AFS108STB42	61,0	42,8	77,77	102	42,88	90	45	25	13,5	M12x45	1/2x1"3/4	4225	1,14
172	2"1/2	AFS110STB54	77,0	54	88,90	114	50,80	105	50	25	13,5	M12x45	1/2x1"3/4	4275	1,55
138	3"	AFS112STB67	92,0	67,7	106,38	134	61,93	124	50	27	17,5	M16x50	5/8x2"	4337	2,33
138	4"	AFS116STB87	115,5	87,3	130,18	162	77,77	146	48	27	17,5	M16x50	5/8x2"	4437	2,85
138	5"	AFS118STB109 (•)	140,2	109,5	152,40	184	92,08	180	50	28	17,5	M16x50	5/8x2"	4537	3,60

### SERIE 6000

414	1/2"	AFS401ST012B11	21,5	11,8	40,49	57	18,24	46	36	16	9	M8x30	5/16x1"1/4	4075	0,24
414	3/4"	AFS402STB15	28,0	15,6	50,80	71	23,80	55	35	21	11	M10x40	3/8x1"1/2	4100	0,48
414	1"	AFS403STB20	34,0	20,7	57,15	79	27,76	68	41	21	13	M12x45	7/16x1"3/4	4131	0,64
414	1"1/4	AFS404STB29	42,8	29,5	66,68	93	31,75	78	44	25	15 *	M14x45	1/2x1"3/4	4150	1,00
414	1"1/2	AFS405STB34	48,6	34	79,38	112	36,50	94	55	28	17	M16x50	5/8x2"	4187	1,68
414	2"	AFS406STB42	61,0	42,8	96,82	134	44,45	114	65	37	21	M20x70	3/4x2"1/2	4225	2,86
350	2"1/2	AFS507STB54	76,6	54	123,80	180	58,70	152	80	45	26	M24x80	—	4275	6,40
350	3"	AFS508STB67	90,0	67,7	152,40	208	71,40	178	90	55	33	M30x100	—	4337	

PER QUESTA TIPOLOGIA DI PRODOTTO, VERIFICATE SEMPRE SE LA QUOTA "A" E "B" CORRISPONDE ALLA SCHEDULA DEL VOSTRO TUBO

FOR THIS KIND OF PRODUCT, PLEASE ALWAYS VERIFY IF DIMENSION "A" AND "B" CORRESPOND TO THE SCHEDULE OF YOUR TUBE

DESIGNAZIONE PER ORDINE DESIGNATION FOR ORDER	Materiale / Material	
	ST52.3	AISI 316L
Solo flangia Only flange	<b>AFS...STB</b>	<b>AFX...STB</b>
Flangia completa di viti metriche, grower e o-ring Flange complete of metric screws, grower type washers and o-ring	<b>AFS...STB...M</b>	<b>AFX...STB...M</b>
Flangia completa di viti unc, grower e o-ring Flange complete of unc screws, grower type washers and o-ring	<b>AFS...STB...U</b>	<b>AFX...STB...U</b>

#### NOTE / NOTES

\* Per viti unc L=13,5  
\* For unc screws L=13,5

(•) Solo in ST52.3  
(•) Only in ST52.3

set viti unc disponibili solo in acciaio al carbonio.  
unc screws set available only in carbon steel.



# FLANGE A SALDARE DI TESTA SCH.XXS

## WELD ON FLANGES SCH.XXS

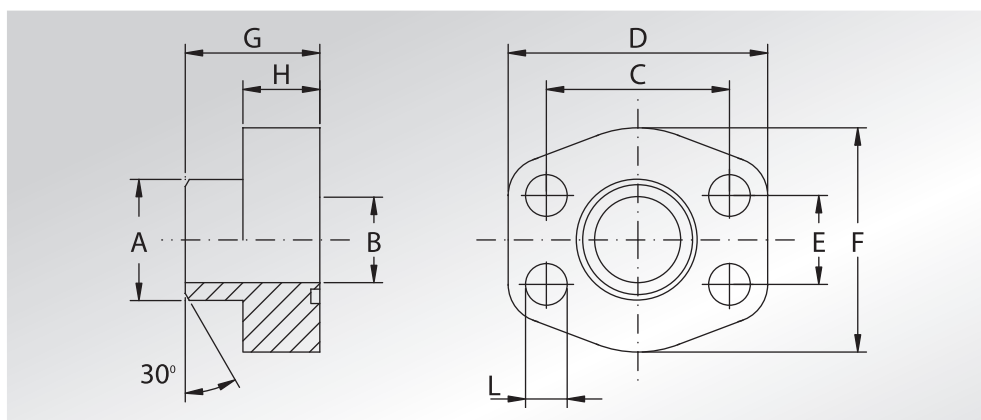

Pressione max di esercizio raccomandata Kg/cm <sup>2</sup>	Grandezza	Tipo	Dimensioni									Viti		Or tipo	Peso Kg
Maximum recommended working pressure Kg/cm <sup>2</sup>	Size	Type	Dimensions									Screws		Or type	Weight Kg
			A	B	C	D	E	F	G	H	L	Metric	Unc		

### SERIE 3000

345	1/2"	AFS080STB6	21,5	6,3	38,10	57	17,48	46	36	16	9	M8x30	5/16x1"1/4	4075	0,24
345	3/4"	AFS100STB11	28,0	11,0	47,63	65	22,23	50	36	18	11	M10x35	3/8x1"1/2	4100	0,35
345	1"	AFS102STB15	34,0	15,2	52,37	70	26,19	55	38	18	11	M10x35	3/8x1"1/2	4131	0,41
276	1"1/4	AFS104STB22	42,8	22,8	58,72	79	30,18	68	41	21	11,5	M10x40	7/16x1"3/4	4150	0,64
207	1"1/2	AFS106STB28	48,6	28,0	69,85	93	35,71	78	44	25	13,5	M12x45	1/2x1"3/4	4187	0,98
207	2"	AFS108STB38	61,0	38,2	77,77	102	42,88	90	45	25	13,5	M12x45	1/2x1"3/4	4225	1,14
172	2"1/2	AFS110STB45	77,0	45,0	88,90	114	50,80	105	50	25	13,5	M12x45	1/2x1"3/4	4275	1,55
138	3"	AFS112STB58	92,0	58,4	106,38	134	61,93	124	50	27	17,5	M16x50	5/8x2"	4337	2,33
138	4"	AFS116STB80	115,5	80,0	130,18	162	77,77	146	48	27	17,5	M16x50	5/8x2"	4437	2,85
138	5"	AFS118STB102 (•)	140,2	102,9	152,40	184	92,08	180	50	28	17,5	M16x50	5/8x2"	4537	3,60

### SERIE 6000

414	1/2"	AFS401ST012B6	21,5	6,3	40,49	57	18,24	46	36	16	9	M8x30	5/16x1"1/4	4075	0,24
414	3/4"	AFS402STB11	28,0	11,0	50,80	71	23,80	55	35	21	11	M10x40	3/8x1"1/2	4100	0,48
414	1"	AFS403STB15	34,0	15,2	57,15	79	27,76	68	41	21	13	M12x45	7/16x1"3/4	4131	0,64
414	1"1/4	AFS404STB22	42,8	22,8	66,68	93	31,75	78	44	25	15 *	M14x45	1/2x1"3/4	4150	1,00
414	1"1/2	AFS405STB28	48,6	28,0	79,38	112	36,50	94	55	28	17	M16x50	5/8x2"	4187	1,68
414	2"	AFS406STB38	61,0	38,2	96,82	134	44,45	114	65	37	21	M20x70	3/4x2"1/2	4225	2,86
414	2"1/2	AFS507STB45	76,6	45,0	123,80	180	58,70	152	80	45	26	M24x80	-	4275	6,40
414	3"	AFS508STB58	90,0	58,4	152,40	208	71,40	178	90	55	33	M30x100	-	4337	-

PER QUESTA TIPOLOGIA DI PRODOTTO, VERIFICATE SEMPRE SE LA QUOTA "A" E "B" CORRISPONDE ALLA SCHEDULA DEL VOSTRO TUBO

FOR THIS KIND OF PRODUCT, PLEASE ALWAYS VERIFY IF DIMENSION "A" AND "B" CORRESPOND TO THE SCHEDULE OF YOUR TUBE

DESIGNAZIONE PER ORDINE DESIGNATION FOR ORDER	Materiale / Material	
	ST52.3	AISI 316L
Solo flangia Only flange	<b>AFS...STB</b>	<b>AFX...STB</b>
Flangia completa di viti metriche, grower e o-ring Flange complete of metric screws, grower type washers and o-ring	<b>AFS...STB...M</b>	<b>AFX...STB...M</b>
Flangia completa di viti unc, grower e o-ring Flange complete of unc screws, grower type washers and o-ring	<b>AFS...STB...U</b>	<b>AFX...STB...U</b>

### NOTE / NOTES

\* Per viti unc L=13,5  
\* For unc screws L=13,5

(•) Solo in ST52.3  
(•) Only in ST52.3

set viti unc disponibili solo in acciaio al carbonio.  
unc screws set available only in carbon steel.



**CONTROFLANGE  
A SALDARE  
DI TESTA SCH.80**



**WELD ON  
COUNTER-FLANGES  
SCH.80**

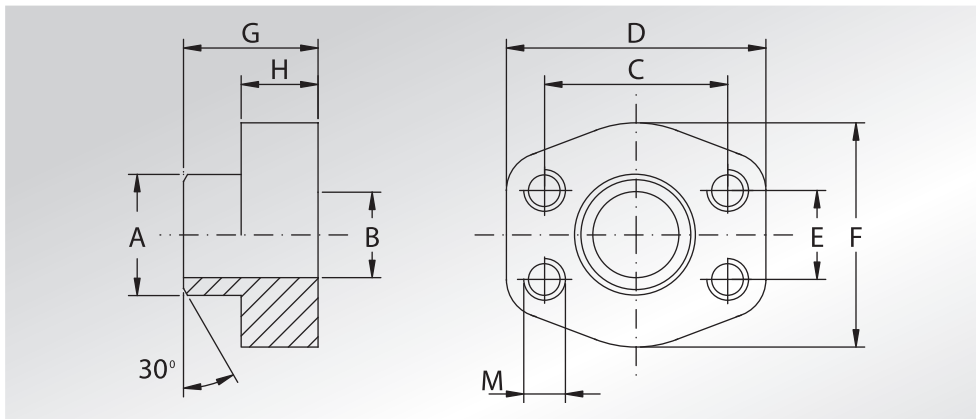

Pressione max di esercizio raccomandata Kg/cm <sup>2</sup>	Grandezza	Tipo	Dimensioni										Peso Kg	
Maximum recommended working pressure Kg/cm <sup>2</sup>	Size	Type	Dimensions										Weight Kg	
			A	B	C	D	E	F	G	H	M	Metric	Unc	
<b>SERIE 3000</b>														
345	1/2"	GFS080ST	21,5	13	38,10	57	17,48	46	36	16	M8	5/16	0,25	
345	1/2"	GFS080ST038	17,5	13	38,10	57	17,48	46	36	16	M8	5/16	0,23	
345	3/4"	GFS100ST	28,0	19	47,63	65	22,23	50	36	18	M10	3/8	0,39	
345	1"	GFS102ST	34,0	25	52,37	70	26,19	55	38	18	M10	3/8	0,45	
276	1"1/4	GFS104ST	42,8	32	58,72	79	30,18	68	41	21	M10	7/16	0,69	
207	1"1/2	GFS106ST	48,6	38	69,85	93	35,71	78	44	25	M12	1/2	1,05	
207	2"	GFS108ST	61,0	51	77,77	102	42,88	90	45	25	M12	1/2	1,22	
172	2"1/2	GFS110ST	77,0	63	88,90	114	50,80	105	50	25	M12	1/2	1,63	
138	3"	GFS112ST	92,0	73	106,38	134	61,93	124	50	27	M16	5/8	2,42	
34	3"1/2	GFS114ST	103,0	89	120,65	152	69,85	136	48	27	M16	5/8	2,49	
34	4"	GFS116ST	115,5	99	130,18	162	77,77	146	48	27	M16	5/8	2,94	
34	5"	GFS118ST (•)	140,2	120	152,40	184	92,08	180	50	28	M16	5/8	3,60	
<b>SERIE 6000</b>														
414	1/2"	GFS401ST012	21,5	13	40,49	57	18,24	46	36	16	M8	5/16	0,25	
414	1/2"	GFS401ST038	17,5	13	40,49	57	18,24	46	36	16	M8	5/16	0,23	
414	3/4"	GFS402ST	28,0	19	50,80	71	23,80	55	35	21	M10	3/8	0,52	
414	1"	GFS403ST	34,0	25	57,15	79	27,76	68	41	21	M12	7/16	0,70	
375	1"1/4	GFS404ST	42,8	32	66,68	93	31,75	78	44	25	M14	1/2	1,08	
320	1"1/2	GFS405ST	48,6	38	79,38	112	36,50	94	55	30	M16	5/8	1,76	
250	2"	GFS406ST	61,0	51	96,82	134	44,45	114	65	37	M20	3/4	2,98	
230	2"1/2	GFS507ST	76,6	63	123,80	180	58,70	152	80	45	M24	—	6,50	
200	3"	GFS508ST	90,0	73	152,40	208	71,40	178	90	55	M30	—	—	

PER QUESTA TIPOLOGIA DI PRODOTTO, VERIFICATE SEMPRE SE LA QUOTA "A" E "B" CORRISPONDE ALLA SCHEDULA DEL VOSTRO TUBO

FOR THIS KIND OF PRODUCT, PLEASE ALWAYS VERIFY IF DIMENSION "A" AND "B" CORRESPOND TO THE SCHEDULE OF YOUR TUBE

DESIGNAZIONE PER ORDINE DESIGNATION FOR ORDER	Materiale / Material	
	ST52.3	AISI 316L
Controflangia con fori di fissaggio filettati metrici Counter-flange with metric threaded fixing holes	<b>GFS...ST</b>	<b>GFX...ST</b>
Controflangia con fori di fissaggio filettati unc Counter-flange with unc threaded fixing holes	<b>GFS...STU</b>	<b>GFX...STU</b>

**NOTE / NOTES**

- (•) Solo in ST52.3
- (•) Only in ST52.3



# CONTROFLANGE A SALDARE DI TESTA SCH.160

## WELD ON COUNTER-FLANGES SCH.160

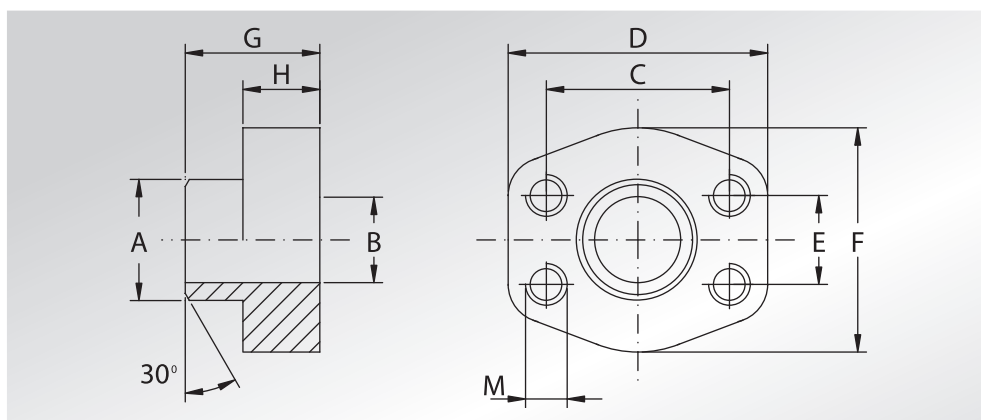

Pressione max di esercizio raccomandata Kg/cm <sup>2</sup>	Grandezza	Tipo	Dimensioni										Peso Kg	
Maximum recommended working pressure Kg/cm <sup>2</sup>	Size	Type	Dimensions										Weight Kg	
			A	B	C	D	E	F	G	H	M			
<b>SERIE 3000</b>													<b>Metric</b>	<b>Unc</b>
345	1/2"	GFS080STB11	21,5	11,8	38,10	57	17,48	46	36	16	M8	5/16	0,25	
345	3/4"	GFS100STB15	28,0	15,6	47,63	65	22,23	50	36	18	M10	3/8	0,39	
345	1"	GFS102STB20	34,0	20,7	52,37	70	26,19	55	38	18	M10	3/8	0,45	
276	1"1/4	GFS104STB29	42,8	29,5	58,72	79	30,18	68	41	21	M10	7/16	0,69	
207	1"1/2	GFS106STB34	48,6	34	69,85	93	35,71	78	44	25	M12	1/2	1,05	
207	2"	GFS108STB42	61,0	42,8	77,77	102	42,88	90	45	25	M12	1/2	1,22	
172	2"1/2	GFS110STB54	77,0	54	88,90	114	50,80	105	50	25	M12	1/2	1,63	
138	3"	GFS112STB67	92,0	67,7	106,38	134	61,93	124	50	27	M16	5/8	2,42	
34	4"	GFS116STB87	115,5	87,3	130,18	162	77,77	146	48	27	M16	5/8	2,94	
34	5"	GFS118STB109 (•)	140,2	109,5	152,40	184	92,08	180	50	28	M16	5/8	3,60	
<b>SERIE 6000</b>														
414	1/2"	GFS401ST012B11	21,5	11,8	40,49	57	18,24	46	36	16	M8	5/16	0,25	
414	3/4"	GFS402STB15	28,0	15,6	50,80	71	23,80	55	35	21	M10	3/8	0,52	
414	1"	GFS403STB20	34,0	20,7	57,15	79	27,76	68	41	21	M12	7/16	0,70	
414	1"1/4	GFS404STB29	42,8	29,5	66,68	93	31,75	78	44	25	M14	1/2	1,08	
414	1"1/2	GFS405STB34	48,6	34	79,38	112	36,50	94	55	28	M16	5/8	1,76	
414	2"	GFS406STB42	61,0	42,8	96,82	134	44,45	114	65	37	M20	3/4	2,98	
350	2"1/2	GFS507STB54	76,6	54	123,80	180	58,70	152	80	45	M24	—	6,50	
350	3"	GFS508STB67	90,0	67,7	152,40	208	71,40	178	90	55	M30	—	-	

PER QUESTA TIPOLOGIA DI PRODOTTO, VERIFICATE SEMPRE SE LA QUOTA "A" E "B" CORRISPONDE ALLA SCHEDULA DEL VOSTRO TUBO

FOR THIS KIND OF PRODUCT, PLEASE ALWAYS VERIFY IF DIMENSION "A" AND "B" CORRESPOND TO THE SCHEDULE OF YOUR TUBE

DESIGNAZIONE PER ORDINE DESIGNATION FOR ORDER	Materiale / Material	
	ST52.3	AISI 316L
Controflangia con fori di fissaggio filettati metrici Counter-flange with metric threaded fixing holes	<b>GFS...STB</b>	<b>GFX...STB</b>
Controflangia con fori di fissaggio filettati unc Counter-flange with unc threaded fixing holes	<b>GFS...STB...U</b>	<b>GFX...STB...U</b>

### NOTE / NOTES

- (•) Solo in ST52.3
- (•) Only in ST52.3

# CONTROFLANGE A SALDARE DI TESTA SCH.XXS



## WELD ON COUNTER-FLANGES SCH.XXS

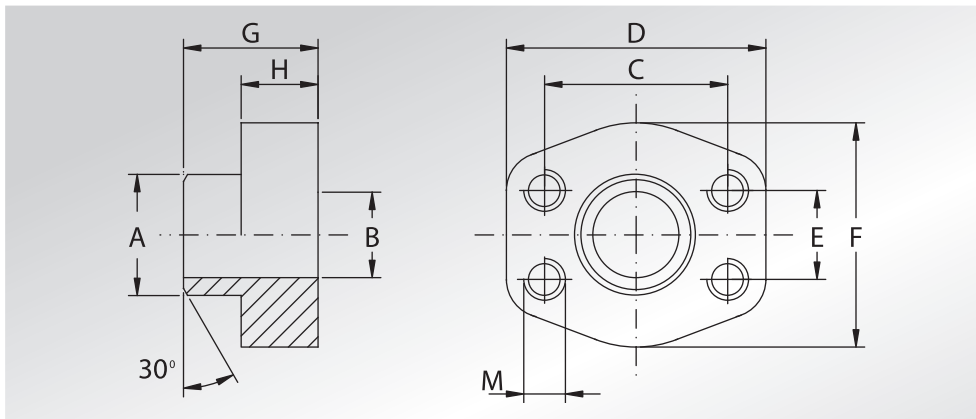

Pressione max di esercizio raccomandata Kg/cm <sup>2</sup>	Grandezza	Tipo	Dimensioni										Peso Kg	
			Dimensions											
Maximum recommended working pressure Kg/cm <sup>2</sup>	Size	Type	A	B	C	D	E	F	G	H	M		Weight Kg	
<b>SERIE 3000</b>													<b>Metric</b>	<b>Unc</b>
345	1/2"	GFS080STB6	21,5	6,3	38,10	57	17,48	46	36	16	M8	5/16	0,25	
345	3/4"	GFS100STB11	28,0	11,0	47,63	65	22,23	50	36	18	M10	3/8	0,39	
345	1"	GFS102STB15	34,0	15,2	52,37	70	26,19	55	38	18	M10	3/8	0,45	
276	1"1/4	GFS104STB22	42,8	22,8	58,72	79	30,18	68	41	21	M10	7/16	0,69	
207	1"1/2	GFS106STB28	48,6	28,0	69,85	93	35,71	78	44	25	M12	1/2	1,05	
207	2"	GFS108STB38	61,0	38,2	77,77	102	42,88	90	45	25	M12	1/2	1,22	
172	2"1/2	GFS110STB45	77,0	45,0	88,90	114	50,80	105	50	25	M12	1/2	1,63	
138	3"	GFS112STB58	92,0	58,4	106,38	134	61,93	124	50	27	M16	5/8	2,42	
34	4"	GFS116STB80	115,5	80,0	130,18	162	77,77	146	48	27	M16	5/8	2,94	
34	5"	GFS118STB102 (•)	140,2	102,9	152,40	184	92,08	180	50	28	M16	5/8	3,60	
<b>SERIE 6000</b>														
414	1/2"	GFS401ST012B6	21,5	6,3	40,49	57	18,24	46	36	16	M8	5/16	0,25	
414	3/4"	GFS402STB11	28,0	11,0	50,80	71	23,80	55	35	21	M10	3/8	0,52	
414	1"	GFS403STB15	34,0	15,2	57,15	79	27,76	68	41	21	M12	7/16	0,70	
414	1"1/4	GFS404STB22	42,8	22,8	66,68	93	31,75	78	44	25	M14	1/2	1,08	
414	1"1/2	GFS405STB28	48,6	28,0	79,38	112	36,50	94	55	28	M16	5/8	1,76	
414	2"	GFS406STB38	61,0	38,2	96,82	134	44,45	114	65	37	M20	3/4	2,98	
414	2"1/2	GFS507STB45	76,6	45,0	123,80	180	58,70	152	80	45	M24	—	6,50	
414	3"	GFS508STB58	90,0	58,4	152,40	208	71,40	178	90	55	M30	—	-	

PER QUESTA TIPOLOGIA DI PRODOTTO, VERIFICATE SEMPRE SE LA QUOTA "A" E "B" CORRISPONDE ALLA SCHEDULA DEL VOSTRO TUBO

FOR THIS KIND OF PRODUCT, PLEASE ALWAYS VERIFY IF DIMENSION "A" AND "B" CORRESPOND TO THE SCHEDULE OF YOUR TUBE

DESIGNAZIONE PER ORDINE DESIGNATION FOR ORDER	Materiale / Material	
	ST52.3	AISI 316L
Controflangia con fori di fissaggio filettati metrici Counter-flange with metric threaded fixing holes	<b>GFS...STB</b>	<b>GFX...STB</b>
Controflangia con fori di fissaggio filettati unc Counter-flange with unc threaded fixing holes	<b>GFS...STB...U</b>	<b>GFX...STB...U</b>

### NOTE / NOTES

(•) Solo in ST52.3

(•) Only in ST52.3



**DOPPIE FLANGE  
A SALDARE  
DI TESTA  
SCH.80; SCH.160;  
SCH.XXS**

**WELD ON  
DOUBLE FLANGES  
SCH.80; SCH.160;  
SCH.XXS**

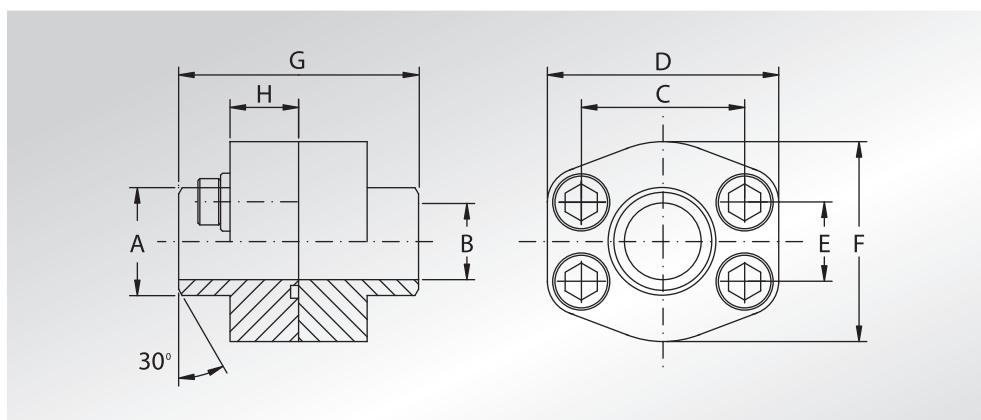

Pressione max di esercizio raccomandata Kg/cm <sup>2</sup>	Grandezza	Tipo	Dimensioni										Viti		Or tipo	Peso Kg
Maximum recommended working pressure Kg/cm <sup>2</sup>	Size	Type	Dimensions										Screws		Or type	Weight Kg
			A	B	C	D	E	F	G	H	Metric	Unc				

**SERIE 3000**

			SCH.80	SCH.160	SCH.XXS											
345	1/2"	DFS080ST	21,5	13	11,8	6,3	38,10	57	17,48	46	72	32	M8x30	5/16x1"1/4	4075	0,55
345	1/2"	DFS080ST038	17,5	13	—	—	38,10	57	17,48	46	72	32	M8x30	5/16x1"1/4	4075	0,51
345	3/4"	DFS100ST	28,0	19	15,6	11,0	47,63	65	22,23	50	72	36	M10x35	3/8x1"1/2	4100	0,86
345	1"	DFS102ST	34,0	25	20,7	15,2	52,37	70	26,19	55	76	36	M10x35	3/8x1"1/2	4131	0,98
276	1"1/4	DFS104ST	42,8	32	29,5	22,8	58,72	79	30,18	68	82	42	M10x40	7/16x1"3/4	4150	1,47
207	1"1/2	DFS106ST	48,6	38	34	28,0	69,85	93	35,71	78	88	50	M12x45	1/2x1"3/4	4187	2,23
207	2"	DFS108ST	61,0	51	42,8	38,2	77,77	102	42,88	90	90	50	M12x45	1/2x1"3/4	4225	2,56
172	2"1/2	DFS110ST	77,0	63	54	45,0	88,90	114	50,80	105	100	50	M12x45	1/2x1"3/4	4275	3,38
138	3"	DFS112ST	92,0	73	67,7	58,4	106,38	134	61,93	124	100	54	M16x50	5/8x2"	4337	5,18
34	3"1/2	DFS114ST	103,0	89	—	—	120,65	152	69,85	136	96	54	M16x50	5/8x2"	4387	5,23
34	4"	DFS116ST	115,5	99	87,3	80,0	130,18	162	77,77	146	96	54	M16x50	5/8x2"	4437	6,22
34	5"	DFS118ST (*)	140,2	120	109,5	102,9	152,40	184	92,08	180	100	56	M16x50	5/8x2"	4537	7,72

**SERIE 6000**

414	1/2"	DFS401ST012	21,5	13	11,8	6,3	40,49	57	18,24	46	72	32	M8x30	5/16x1"1/4	4075	0,55
414	1/2"	DFS401ST038	17,5	13	—	—	40,49	57	18,24	46	72	32	M8x30	5/16x1"1/4	4075	0,51
414	3/4"	DFS402ST	28,0	19	15,6	11,0	50,80	71	23,80	55	70	42	M10x40	3/8x1"1/2	4100	1,13
414	1"	DFS403ST	34,0	25	20,7	15,2	57,15	79	27,76	68	82	42	M12x45	7/16x1"3/4	4131	1,54
375	1"1/4	DFS404ST	42,8	32	29,5	22,8	66,68	93	31,75	78	88	50	M14x45	1/2x1"3/4	4150	2,37
320	1"1/2	DFS405ST	48,6	38	34	28,0	79,38	112	36,50	94	110	60	M16x50	5/8x2"	4187	3,87
250	2"	DFS406ST	61,0	51	42,8	38,2	96,82	134	44,45	114	130	74	M20x70	3/4x2"1/2	4225	6,75
230	2"1/2	DFS507ST (*)	76,6	63	54	45,0	123,80	180	58,70	152	160	90	M24x80	—	4275	-
200	3"	DFS508ST (*)	90,0	73	67,7	58,4	152,40	208	71,40	178	180	110	M30x100	—	4337	-

PER QUESTA TIPOLOGIA DI PRODOTTO, VERIFICATE SEMPRE SE LA QUOTA "A" E "B" CORRISPONDE ALLA SCHEDULA DEL VOSTRO TUBO

FOR THIS KIND OF PRODUCT, PLEASE ALWAYS VERIFY IF DIMENSION "A" AND "B" CORRESPOND TO THE SCHEDULE OF YOUR TUBE

DESIGNAZIONE PER ORDINE DESIGNATION FOR ORDER	Materiale / Material	
	ST52.3	AISI 316L
Flangia + controflangia + set viti metriche Flange + counter-flange + metric screws set	<b>DFS...STM</b>	<b>DFX...STM</b>
Flangia + controflangia + set viti unc Flange + counter-flange + unc screws set	<b>DFS...STU</b>	<b>DFX...STU</b>

**NOTE / NOTES**

\* Per viti unc L=13,5  
\* For unc screws L=13,5

(•) Solo in ST52.3  
(•) Only in ST52.3

set viti unc disponibili solo in acciaio al carbonio.  
unc screws set available only in carbon steel.

(\*) set viti disponibili solo in acciaio al carbonio.  
(\*) screws set available only in carbon steel.

**FLANGE  
A SALDARE DI  
TESTA  
TUBO METRICO  
FORO CILINDRICO**



**METRIC PIPE  
CYLINDRIC HOLE  
WELD ON FLANGES**

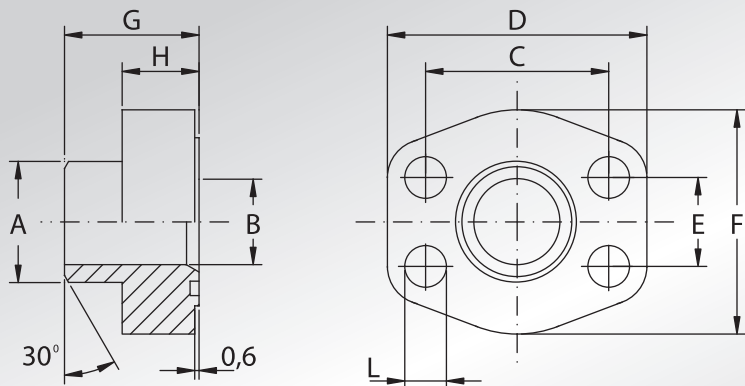

Pressione max di esercizio raccomandata Kg/cm <sup>2</sup>	Grandezza	Tipo	Dimensioni									Viti		Or tipo	Peso Kg
Maximum recommended working pressure Kg/cm <sup>2</sup>	Size	Type	Dimensions									Screws		Or type	Weight Kg
			A	B	C	D	E	F	G	H	L	Metric	Unc		

**SERIE 3000**

345	3/4"	AFS100SRE25	25	19	47,63	65	22,23	50	36	18	11	M10x35	3/8x1"1/2	4100	0,35
345	1"	AFS102SRE30	30	22	52,37	70	26,19	55	38	18	11	M10x35	3/8x1"1/2	4131	0,41
276	1"1/4	AFS104SRE38	38	30	58,72	79	30,18	68	41	21	11,5	M10x40	7/16x1"3/4	4150	0,64
207	1"1/2	AFS106SRE42	42	36	69,85	93	35,71	78	44,5	24,5	13,5	M12x45	1/2x1"3/4	4187	0,98
207	1"1/2	AFS106SRE48	49	38	69,85	93	35,71	78	44,5	24,5	13,5	M12x45	1/2x1"3/4	4187	0,98
207	2"	AFS108STRE48	49	42	77,77	102	42,88	90	45	25	13,5	M12x45	1/2x1"3/4	4225	1,14
207	2"	AFS108SRE60	61	49	77,77	102	42,88	90	45	25	13,5	M12x45	1/2x1"3/4	4225	1,14
172	2"1/2	AFS110SRE76	77	62	88,90	114	50,80	105	50	25	13,5	M12x45	1/2x1"3/4	4275	1,55
138	3"	AFS112STRE76	77	70	106,38	134	61,93	124	51	26	17,5	M16x50	5/8x2"	4337	2,33
138	3"	AFS112SRE76	77	62	106,38	134	61,93	124	51	26	17,5	M16x50	5/8x2"	4337	2,33
34	3"1/2	AFS114STRE76	77	70	120,65	152	69,85	136	48	26	17,5	M16x50	5/8x2"	4387	2,40
34	3"1/2	AFS114STRE88	90	82	120,65	152	69,85	136	48	26	17,5	M16x50	5/8x2"	4387	2,40
34	4"	AFS116STRE76	77	70	130,18	162	77,77	146	48	26	17,5	M16x50	5/8x2"	4437	2,85
34	4"	AFS116STRE88	90	82	130,18	162	77,77	146	48	26	17,5	M16x50	5/8x2"	4437	2,85

**SERIE 6000**

414	1/2"	AFS401SRE20	20	14	40,49	57	18,24	46	34	16	9	M8x30	5/16x1"1/4	4075	0,24
414	3/4"	AFS402SRE20	20	14	50,80	71	23,80	55	35	21	11	M10x40	3/8x1"1/2	4100	0,48
414	3/4"	AFS402SRE25	25	17	50,80	71	23,80	55	35	21	11	M10x40	3/8x1"1/2	4100	0,48
414	1"	AFS403SRE25	25	19	57,15	81	27,76	65	42	25	13	M12x45	7/16x1"3/4	4131	0,64
414	1"	AFS403SRE30	30	22	57,15	81	27,76	65	42	25	13	M12x45	7/16x1"3/4	4131	0,64
414	1"1/4	AFS404SRE38	38	28	66,68	95	31,75	78	44	25	15 *	M14x45	1/2x1"3/4	4150	1,00
414	1"1/4	AFS404SRE38B26	38	26	66,68	95	31,75	78	44	25	15 *	M14x45	1/2x1"3/4	4150	1,00
414	1"1/2	AFS405SRE38	38	28	79,38	112	36,50	94	56	28	17	M16x50	5/8x2"	4187	1,69
414	1"1/2	AFS405SRE48B32	48,6	32	79,38	112	36,50	94	56	28	17	M16x50	5/8x2"	4187	1,69
414	2"	AFS406SRE60	61	40	96,82	134	44,45	114	65	37	21	M20x70	3/4x2"1/2	4225	2,86
414	2"1/2	AFS507SRE76	76,6	50	123,80	180	58,70	152	80	45	26	M24x80	—	4275	6,40

**DESIGNAZIONE PER ORDINE  
DESIGNATION FOR ORDER**

Solo flangia  
Only flange

Flangia completa di viti metriche, grower e o-ring  
Flange complete of metric screws, grower type washers and o-ring

Flangia completa di viti unc, grower e o-ring  
Flange complete of unc screws, grower type washers and o-ring

**Materiale / Material**

**ST52.3**      **AISI 316L**

**AFS...SRE/STRE**      **AFX...SRE/STRE**

**AFS...SRE...M/STRE...M**      **AFX...SRE...M/STRE...M**

**AFS...SRE...U/STRE...U**      **AFX...SRE...U/STRE...U**

**NOTE / NOTES**

\* Per viti unc L=13,5  
\* For unc screws L=13,5

set viti unc disponibili solo in acciaio al carbonio.  
unc screws set available only in carbon steel.



# FLANGE A SALDARE DI TESTA TUBO METRICO

## METRIC PIPE WELD ON FLANGES

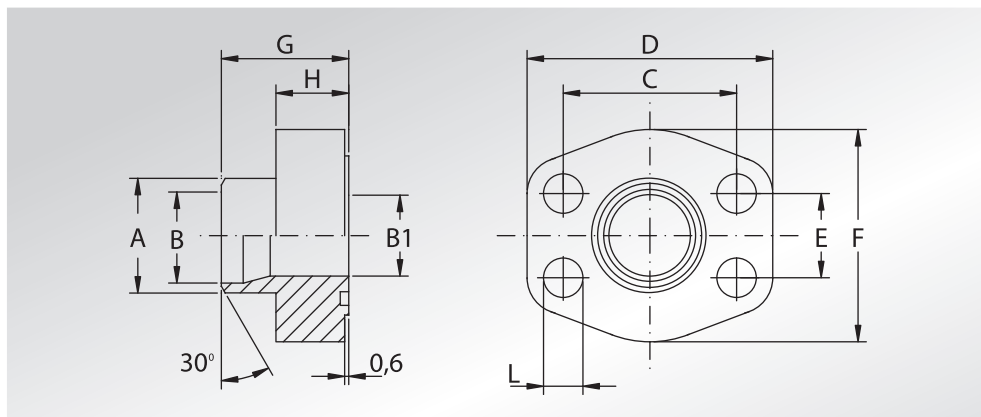

Pressione max di esercizio raccomandata Kg/cm <sup>2</sup>	Grandezza	Tipo	Dimensioni										Viti		Or tipo	Peso Kg
Maximum recommended working pressure Kg/cm <sup>2</sup>	Size	Type	Dimensions										Screws		Or type	Weight Kg
			A	B	B1	C	D	E	F	G	H	L	Metric	Unc		

### SERIE 3000

345	1/2"	AFS080SRE20	20	14	13	38,10	57	17,48	46	35	16	9	M8x30	5/16x1"1/4	4075	0,24
345	1/2"	AFS080SRE22	22	16	13	38,10	57	17,48	46	35	16	9	M8x30	5/16x1"1/4	4075	0,24
345	3/4"	AFS100SRE28	28	21,5	19	47,63	65	22,23	50	36	18	11	M10x35	3/8x1"1/2	4100	0,35
345	1"	AFS102SRE35	35	27	25	52,37	70	26,19	55	38	18	11	M10x35	3/8x1"1/2	4131	0,46
276	1"1/4	AFS104SRE42	43	36	31	58,72	79	30,18	68	41	21	11,5	M10x40	7/16x1"3/4	4150	0,64
207	1"1/2	AFS106STRE48	49	42	38	69,85	93	35,71	78	44,5	24,5	13,5	M12x45	1/2x1"3/4	4187	0,98
207	2"	AFS108STRE60	61	53	49	77,77	102	42,88	90	45	25	13,5	M12x45	1/2x1"3/4	4225	1,14
172	2"1/2	AFS110STRE76	77	70	62	88,90	114	50,80	105	50	25	13,5	M12x45	1/2x1"3/4	4275	1,55
138	3"	AFS112STRE88	90	82	74	106,38	134	61,93	124	51	26	17,5	M16x50	5/8x2"	4337	2,33
34	4"	AFS116STRE114	115	107	102	130,18	162	77,77	146	48	26	17,5	M16x50	5/8x2"	4437	2,85
34	5"	AFS118STREH139 (•)	140,2	131	120	152,40	184	92,08	180	50	28	17,5	M16x50	5/8x2"	4537	3,20

### SERIE 6000

414	1"1/2	AFS405SRE60	61	40	38	79,38	112	36,50	94	56	28	17	M16x50	5/8x2"	4187	1,65
-----	-------	-------------	----	----	----	-------	-----	-------	----	----	----	----	--------	--------	------	------

DESIGNAZIONE PER ORDINE DESIGNATION FOR ORDER	Materiale / Material	
	ST52.3	AISI 316L
Solo flangia Only flange	<b>AFS...SRE/STRE</b>	<b>AFX...SRE/STRE</b>
Flangia completa di viti metriche, grower e o-ring Flange complete of metric screws, grower type washers and o-ring	<b>AFS...SRE...M/STRE...M</b>	<b>AFX...SRE...M/STRE...M</b>
Flangia completa di viti unc, grower e o-ring Flange complete of unc screws, grower type washers and o-ring	<b>AFS...SRE...U/STRE...U</b>	<b>AFX...SRE...U/STRE...U</b>

### NOTE / NOTES

set viti unc disponibili solo in acciaio al carbonio.  
unc screws set available only in carbon steel.

- (•) Solo in ST52.3
- (•) Only in ST52.3

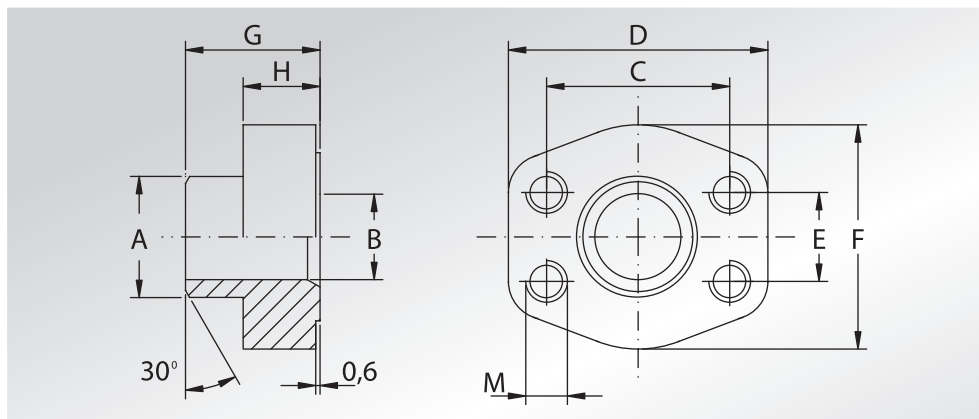

**CONTROFLANGE  
A SALDARE  
DI TESTA  
TUBO METRICO  
FORO CILINDRICO**



**METRIC PIPE  
CYLINDRIC  
HOLE WELD ON  
COUNTER-FLANGES**

Pressione max di esercizio raccomandata Kg/cm <sup>2</sup>	Grandezza	Tipo	Dimensioni										Peso Kg	
Maximum recommended working pressure Kg/cm <sup>2</sup>	Size	Type	Dimensions										Weight Kg	
			A	B	C	D	E	F	G	H	M			
<b>SERIE 3000</b>												<b>Metric</b>	<b>Unc</b>	
345	3/4"	GFS100SRE25	25	19	47,63	65	22,23	50	36	18	M10	3/8	0,39	
345	1"	GFS102SRE30	30	22	52,37	70	26,19	55	38	18	M10	3/8	0,45	
276	1"1/4	GFS104SRE38	38	30	58,72	79	30,18	68	41	21	M10	7/16	0,69	
207	1"1/2	GFS106SRE42	42	36	69,85	93	35,71	78	44,5	24,5	M12	1/2	1,05	
207	1"1/2	GFS106SRE48	49	38	69,85	93	35,71	78	44,5	24,5	M12	1/2	1,05	
207	2"	GFS108STRE48	49	42	77,77	102	42,88	90	45	25	M12	1/2	1,22	
207	2"	GFS108SRE60	61	49	77,77	102	42,88	90	45	25	M12	1/2	1,22	
172	2"1/2	GFS110SRE76	77	62	88,90	114	50,80	105	50	25	M12	1/2	1,63	
138	3"	GFS112STRE76	77	70	106,38	134	61,93	124	51	26	M16	5/8	2,33	
138	3"	GFS112SRE76	77	62	106,38	134	61,93	124	51	26	M16	5/8	2,33	
34	3"1/2	GFS114STRE76	77	70	120,65	152	69,85	136	48	26	M16	5/8	2,49	
34	3"1/2	GFS114STRE88	90	82	120,65	152	69,85	136	48	26	M16	5/8	2,49	
34	4"	GFS116STRE76	77	70	130,18	162	77,77	146	48	26	M16	5/8	2,85	
34	4"	GFS116STRE88	90	82	130,18	162	77,77	146	48	26	M16	5/8	2,85	
<b>SERIE 6000</b>														
414	1/2"	GFS401SRE20	20	14	40,49	57	18,24	46	34	16	M8	5/16	0,25	
414	3/4"	GFS402SRE20	20	14	50,80	71	23,80	55	35	21	M10	3/8	0,52	
414	3/4"	GFS402SRE25	25	17	50,80	71	23,80	55	35	21	M10	3/8	0,52	
414	1"	GFS403SRE25	25	19	57,15	81	27,76	65	42	25	M12	7/16	0,70	
414	1"	GFS403SRE30	30	22	57,15	81	27,76	65	42	25	M12	7/16	0,70	
414	1"1/4	GFS404SRE38	38	28	66,68	95	31,75	78	44	25	M14	1/2	1,08	
414	1"1/4	GFS404SRE38B26	38	26	66,68	95	31,75	78	44	25	M14	1/2	1,08	
414	1"1/2	GFS405SRE38	38	28	79,38	112	36,50	94	56	28	M16	5/8	1,76	
414	1"1/2	GFS405SRE48B32	48,6	32	79,38	112	36,50	94	56	28	M16	5/8	1,76	
414	2"	GFS406SRE60	61	40	96,82	134	44,45	114	65	37	M20	3/4	2,98	
414	2"1/2	GFS507SRE76	76,6	50	123,80	180	58,70	152	80	45	M24	—	6,50	

DESIGNAZIONE PER ORDINE DESIGNATION FOR ORDER	Materiale / Material	
	ST52.3	AISI 316L
Controflangia con fori di fissaggio filettati metrici Counter-flange with metric threaded fixing holes	<b>GFS...SRE / STRE</b>	<b>GFX...SRE / STRE</b>
Controflangia con fori di fissaggio filettati unc Counter-flange with unc threaded fixing holes	<b>GFS...SREU / STREU</b>	<b>GFX...SREU / STREU</b>

NOTE / NOTES



# CONTROFLANGE A SALDARE DI TESTA TUBO METRICO

## METRIC PIPE WELD ON COUNTER-FLANGES

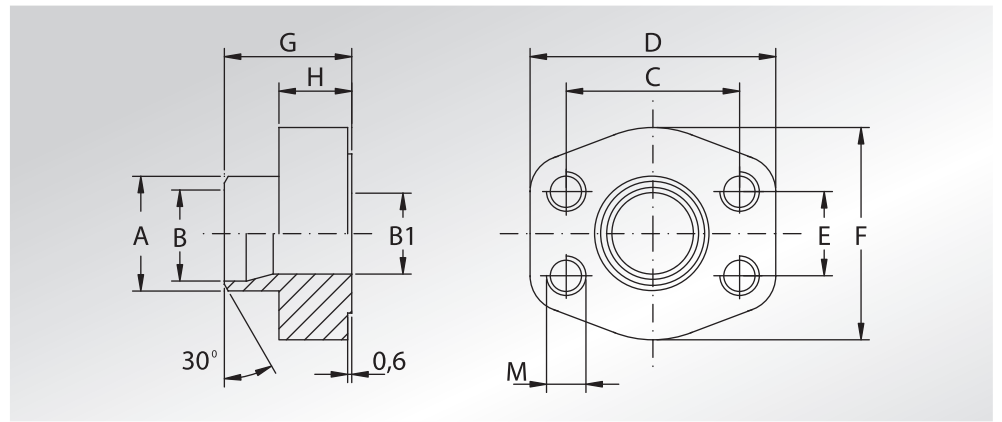

Pressione max di esercizio raccomandata Kg/cm <sup>2</sup>	Grandezza	Tipo	Dimensioni											Peso Kg			
Maximum recommended working pressure Kg/cm <sup>2</sup>	Size	Type	Dimensions											Weight Kg			
			A	B	B1	C	D	E	F	G	H	M					
														Metric	Unc		
<b>SERIE 3000</b>																	
345	1/2"	GFS080SRE20	20	14	13	38,10	57	17,48	46	35	16	M8	5/16	0,25			
345	1/2"	GFS080SRE22	22	16	13	38,10	57	17,48	46	35	16	M8	5/16	0,25			
345	3/4"	GFS100SRE28	28	21,5	19	47,63	65	22,23	50	36	18	M10	3/8	0,39			
345	1"	GFS102SRE35	35	27	25	52,37	70	26,19	55	38	18	M10	3/8	0,45			
276	1"1/4	GFS104SRE42	43	36	31	58,72	79	30,18	68	41	21	M10	7/16	0,69			
207	1"1/2	GFS106STRE48	49	42	38	69,85	93	35,71	78	44,5	24,5	M12	1/2	1,05			
207	2"	GFS108STRE60	61	53	49	77,77	102	42,88	90	45	25	M12	1/2	1,22			
172	2"1/2	GFS110STRE76	77	70	62	88,90	114	50,80	105	50	25	M12	1/2	1,63			
138	3"	GFS112STRE88	90	82	74	106,38	134	61,93	124	51	26	M16	5/8	2,42			
34	4"	GFS116STRE114	115	107	102	130,18	162	77,77	146	48	26	M16	5/8	2,94			
34	5"	GFS118STREH139 (•)	140,2	131	120	152,40	184	92,08	180	50	28	M16	5/8	3,20			
<b>SERIE 6000</b>																	
414	1"1/2	GFS405SRE60	61	40	38	79,38	112	36,50	94	56	28	M16	5/16	1,76			

DESIGNAZIONE PER ORDINE DESIGNATION FOR ORDER	Materiale / Material	
	ST52.3	AISI 316L
Controflangia con fori di fissaggio filettati metrici Counter-flange with metric threaded fixing holes	GFS...SRE / STRE	GFX...SRE / STRE
Controflangia con fori di fissaggio filettati unc Counter-flange with unc threaded fixing holes	GFS...SREU / STREU	GFX...SREU / STREU

### NOTE / NOTES

- (•) Solo in ST52.3
- (•) Only in ST52.3



**FLANGE A 90°  
A SILDARE  
DI TESTA**



**WELD ON  
90° FLANGES**

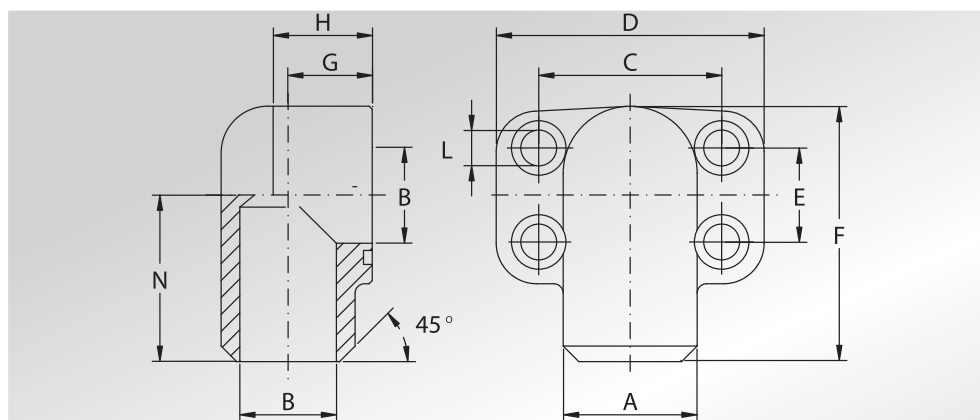

Pressione max di esercizio raccomandata Kg/cm <sup>2</sup>	Grandezza	Tipo	Dimensioni											Viti		Or tipo	Peso Kg
Maximum recommended working pressure Kg/cm <sup>2</sup>	Size	Type	Dimensions											Screws		Or type	Weight Kg
			A	B	C	D	E	F	G	H	L	N	Metric	Unc			

**SERIE 3000**

345	3/4"	AFS20090ST	27,2	19	47,63	70	22,23	63	23	21	11	41	M10x40	—	3100	0,65
345	1"	AFS20290ST	34,5	23	52,37	75	26,19	72	25	24	11	48	M10x40	—	4112	0,85
276	1"1/4	AFS20490ST	43,0	31	58,72	86	30,18	82	27	25	11,5	54	M10x45	—	4150	1,15
207	1"1/2	AFS20690ST	50,0	35	69,85	97	35,71	92	31,5	29	14,0	57	M12x60	—	4187	1,85
207	2"	AFS20890ST	65,0	48	77,77	100	42,88	99	37,5	50	14,0	63	M12x70	—	4225	2,15

**SERIE 6000**

414	3/4"	AFS70090ST	28,0	19	50,80	71	23,80	70	22	19	11	40	M10x35	3/8x1"1/2	4100	0,50
414	1"	AFS70290ST	34,0	25	57,15	81	27,76	82	27	24	13	47	M12x45	7/16x1"3/4	4131	0,80
375	1"1/4	AFS70490ST	42,0	32	66,68	95	31,75	95	32	27	15 *	56	M14x45	1/2x1"3/4	4150	1,20
320	1"1/2	AFS70690ST	48,0	38	79,38	113	36,50	115	40	30	17	68	M16x55	5/8x2"	4187	1,95

**DESIGNAZIONE PER ORDINE  
DESIGNATION FOR ORDER**

**Materiale / Material**

**NOTE / NOTES**

Solo flangia  
Only flange

**AFS...90ST**

\* Per viti unc L=13,5

\* For unc screws L=13,5

Flangia completa di viti metriche, grower e o-ring  
Flange complete of metric screws, grower type washers and o-ring

**AFS...90STM**

Flangia completa di viti unc, grower e o-ring  
Flange complete of unc screws, grower type washers and o-ring

**AFS...90STU**



## FLANGE A 90° A SALDARE DI TESTA

## WELD ON 90° FLANGES

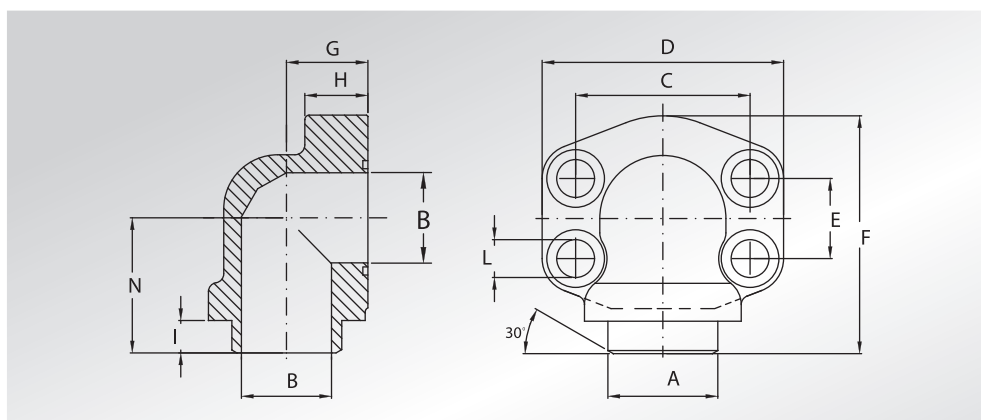

Pressione max di esercizio raccomandata Kg/cm <sup>2</sup>	Grandezza	Tipo	Dimensioni											Viti		Or tipo	Peso Kg
Maximum recommended working pressure Kg/cm <sup>2</sup>	Size	Type	Dimensions											Screws		Or type	Weight Kg
			A	B	C	D	E	F	G	H	I	L	N	Metric	Unc		

### SERIE 3000

345	1/2"	AFS08090ST	21,5	13	38,10	54	17,48	60	20	16	16	9	37	M8x30	5/16x1"1/4	4075	0,28
345	1/2"	AFS08090ST038	17,5	13	38,10	54	17,48	60	20	16	16	9	37	M8x30	5/16x1"1/4	4075	0,29
345	3/4"	AFS10090ST	27,0	19	47,63	65	22,23	63	24	18	16	11	38	M10x35	3/8x1"1/2	4100	0,45
345	1"	AFS10290ST	34,5	25	52,37	70	26,19	70	28	19	19	11	43	M10x35	3/8x1"1/2	4131	0,56
276	1"1/4	AFS10490ST	42,8	32	58,72	79	30,18	85	34	21	21	11,5	51	M10x40	7/16x1"3/4	4150	0,89
207	1"1/2	AFS10690ST	48,6	38	69,85	93	35,71	95	38	25	21	13,5	56	M12x45	1/2x1"3/4	4187	1,18
207	2"	AFS10890ST	61,0	51	77,77	110	42,88	110	42	25	15	13,5	65	M12x45	1/2x1"3/4	4225	2,06

### SERIE 6000

414	1/2"	AFS40190ST012	21,5	13	40,49	54	18,24	60	20	16	16	9	37	M8x30	5/16x1"1/4	4075	0,28
414	1/2"	AFS40190ST038	17,5	13	40,49	54	18,24	60	20	16	16	9	37	M8x30	5/16x1"1/4	4075	0,29
414	3/4"	AFS40290ST	28,0	19	50,80	70	23,80	70	28	19	17	11	43	M10x40	3/8x1"1/2	4100	0,69
414	1"	AFS40390ST	34,0	25	57,15	79	27,76	85	34	21	19	13	51	M12x45	7/16x1"3/4	4131	1,11
414	1"1/4	AFS40490ST	42,8	32	66,68	93	31,75	95	38	25	19	15 *	56	M14x45	1/2x1"3/4	4150	1,45
414	1"1/2	AFS40590ST	48,6	38	79,38	110	36,50	110	42	25	24	17	65	M16x50	5/8x2"	4187	2,75
414	2"	AFS40690ST	61,0	51	96,82	134	44,45	132	45	35	18	21	75	M20x70	3/4x2"1/2	4225	3,55
414	2"	AFS40690SRE60	61,0	40	96,82	134	44,45	132	45	35	18	21	75	M20x70	3/4x2"1/2	4225	3,55
414	2"	AFS40690SRE76	76,0	50	96,82	134	44,45	132	45	35	18	21	75	M20x70	3/4x2"1/2	4225	3,55

PER QUESTA TIPOLOGIA DI PRODOTTO, VERIFICATE SEMPRE SE LA QUOTA "A" E "B" CORRISPONDE ALLA SCHEDULA DEL VOSTRO TUBO

FOR THIS KIND OF PRODUCT, PLEASE ALWAYS VERIFY IF DIMENSION "A" AND "B" CORRESPOND TO THE SCHEDULE OF YOUR TUBE

DESIGNAZIONE PER ORDINE DESIGNATION FOR ORDER	Materiale / Material	
	ST52.3	AISI 316L
Solo flangia Only flange	<b>AFS...90ST</b>	<b>AFX...90ST</b>
Flangia completa di viti metriche, grower e o-ring Flange complete of metric screws, grower type washers and o-ring	<b>AFS...90STM</b>	<b>AFX...90STM</b>
Flangia completa di viti unc, grower e o-ring Flange complete of unc screws, grower type washers and o-ring	<b>AFS...90STU</b>	<b>AFX...90STU</b>

#### NOTE / NOTES

\* Per viti unc L=13,5  
\* For unc screws L=13,5

set viti unc disponibili solo in acciaio al carbonio.  
unc screws set available only in carbon steel.

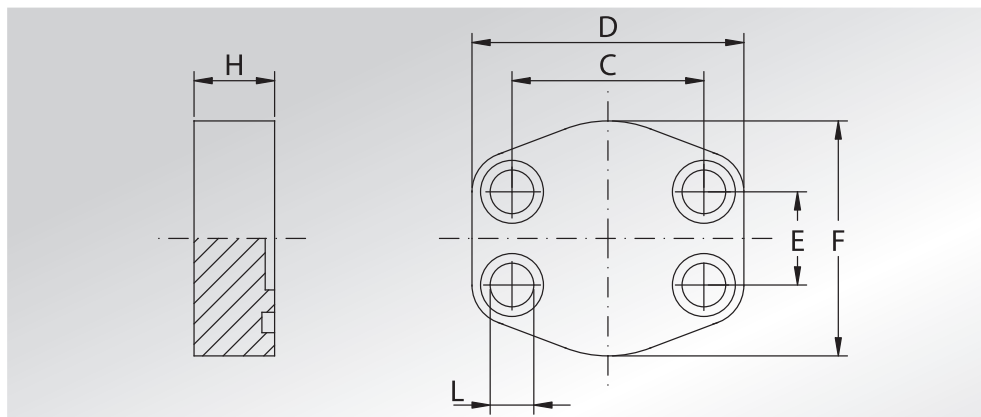

Pressione max di esercizio raccomandata Kg/cm <sup>2</sup>	Grandezza	Tipo	Dimensioni						Viti		Or tipo	Peso Kg
Maximum recommended working pressure Kg/cm <sup>2</sup>	Size	Type	Dimensions						Screws		Or type	Weight Kg
			C	D	E	F	H	L	Metric	Unc		

**SERIE 3000**

345	1/2"	AFC080	38,10	56	17,48	46	16	9	M8x30	5/16x1"1/4	4075	0,24
345	3/4"	AFC100	47,63	65	22,23	50	18	11	M10x35	3/8x1"1/2	4100	0,30
345	1"	AFC102	52,37	70	26,19	60	19	11	M10x35	3/8x1"1/2	4131	0,42
276	1"1/4	AFC104	58,72	79	30,18	68	18	11,5	M10x40	7/16x1"3/4	4150	0,55
207	1"1/2	AFC106	69,85	93	35,71	78	20	13,5	M12x45	1/2x1"3/4	4187	0,82
207	2"	AFC108	77,77	102	42,88	90	20	13,5	M12x45	1/2x1"3/4	4225	1,08
172	2"1/2	AFC110	88,90	114	50,80	105	20	13,5	M12x45	1/2x1"3/4	4275	1,40
138	3"	AFC112	106,38	134	61,93	124	24	17,5	M16x50	5/8x2"	4337	2,38
34	3"1/2	AFC114	120,65	152	69,85	136	22	17,5	M16x50	5/8x2"	4387	2,91
34	4"	AFC116	130,18	162	77,77	146	25	17,5	M16x50	5/8x2"	4437	3,98
34	5"	AFC118 (•)	152,40	190	92,08	170	28	17,5	M16x50	5/8x2"	4537	5,80

**SERIE 6000**

414	1/2"	AFC401	40,49	56	18,24	48	16	9	M8x30	5/16x1"1/4	4075	0,24
414	3/4"	AFC402	50,80	71	23,80	60	19	11	M10x35	3/8x1"1/2	4100	0,42
414	1"	AFC403	57,15	81	27,76	70	24	13	M12x45	7/16x1"3/4	4131	0,77
414	1"1/4	AFC404	66,68	95	31,75	78	27	15 *	M14x45	1/2x1"3/4	4150	1,16
414	1"1/2	AFC405	79,38	112	36,50	94	30	17	M16x50	5/8x2"	4187	1,80
414	2"	AFC406	96,82	134	44,45	114	30	21	M20x60	3/4x2"1/2	4225	2,57
414	2"1/2	AFC507	123,80	180	58,70	152	45	26	M24x80		4275	
414	3"	AFC508	152,40	208	71,40	178	55	33	M30x100		4337	

**DESIGNAZIONE PER ORDINE  
DESIGNATION FOR ORDER**

**Materiale / Material**

**ST52.3**      **AISI 316L**

Solo flangia  
Only flange

**AFC...**

**AFCX...**

Flangia completa di viti metriche, grower e o-ring  
Flange complete of metric screws, grower type washers and o-ring

**AFC...M**

**AFCX...M**

Flangia completa di viti unc, grower e o-ring  
Flange complete of unc screws, grower type washers and o-ring

**AFC...U**

**AFCX...U**

**NOTE / NOTES**

\* Per viti unc L=13,5  
\* For unc screws L=13,5

(•) Solo in ST52.3  
(•) Only in ST52.3

set viti unc disponibili solo in acciaio al carbonio.  
unc screws set available only in carbon steel.



# CONTROFLANGE CIECHE

## BLIND COUNTER-FLANGES

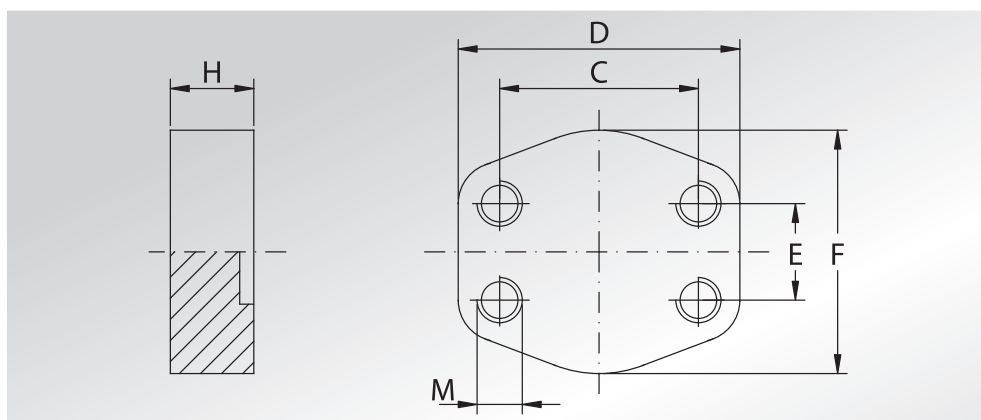

Pressione max di esercizio raccomandata Kg/cm <sup>2</sup>	Grandezza	Tipo	Dimensioni							Peso Kg
Maximum recommended working pressure Kg/cm <sup>2</sup>	Size	Type	Dimensions							Weight Kg
			C	D	E	F	H	M		

### SERIE 3000

								Metric	Unc	
345	1/2"	GFC080	38,10	56	17,48	46	16	M8x30	5/16	0,25
345	3/4"	GFC100	47,63	65	22,23	50	18	M10x35	3/8	0,34
345	1"	GFC102	52,37	70	26,19	60	19	M10x35	3/8	0,46
276	1"1/4	GFC104	58,72	79	30,18	68	18	M10x40	7/16	0,60
207	1"1/2	GFC106	69,85	93	35,71	78	20	M12x45	1/2	0,89
207	2"	GFC108	77,77	102	42,88	90	20	M12x45	1/2	1,15
172	2"1/2	GFC110	88,90	114	50,80	105	20	M12x45	1/2	1,47
138	3"	GFC112	106,38	134	61,93	124	24	M16x50	5/8	2,47
34	3"1/2	GFC114	120,65	152	69,85	136	22	M16x50	5/8	3,00
34	4"	GFC116	130,18	162	77,77	146	25	M16x50	5/8	3,98
34	5"	GFC118 (•)	152,40	190	92,08	170	28	M16x50	5/8	5,80

### SERIE 6000

414	1/2"	GFC401	40,49	56	18,24	48	16	M8x30	5/16	0,25
414	3/4"	GFC402	50,80	71	23,80	60	19	M10x35	3/8	0,46
414	1"	GFC403	57,15	81	27,76	70	24	M12x45	7/16	0,84
414	1"1/4	GFC404	66,68	95	31,75	78	27	M14x45	1/2	1,24
414	1"1/2	GFC405	79,38	112	36,50	94	30	M16x50	5/8	1,89
414	2"	GFC406	96,82	134	44,45	114	30	M20x60	3/4	2,69
414	2"1/2	GFC507	123,80	180	58,70	152	45	M24x100	—	—
414	3"	GFC508	152,40	208	71,40	178	55	M30x100	—	—

#### DESIGNAZIONE PER ORDINE DESIGNATION FOR ORDER

Controflangia con fori di fissaggio filettati metrici  
Counter-flange with metric threaded fixing holes

Controflangia con fori di fissaggio filettati unc  
Counter-flange with unc threaded fixing holes

#### Materiale / Material

ST52.3

AISI 316L

GFC...

GFCX...

GFC...U

GFCX...U

#### NOTE / NOTES

(•) Solo in ST52.3

(•) Only in ST52.3

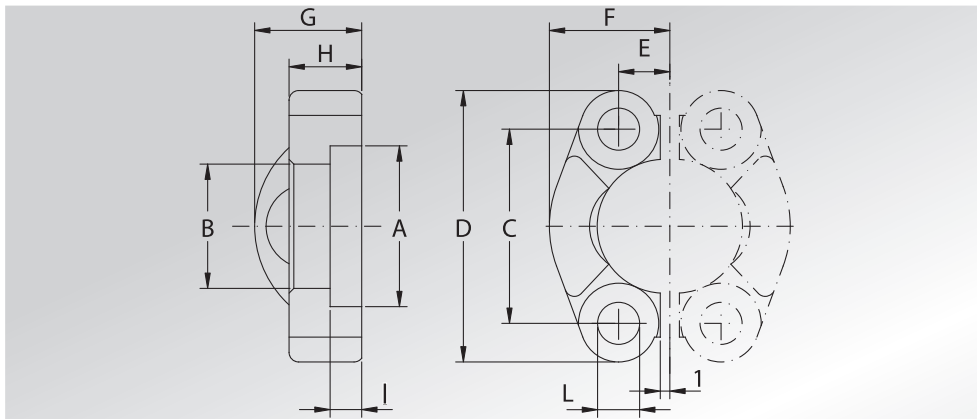

Pressione max di esercizio raccomandata Kg/cm <sup>2</sup>	Grandezza	Tipo	Dimensioni										Viti		Peso Kg
Maximum recommended working pressure Kg/cm <sup>2</sup>	Size	Type	Dimensions										Screws		Weight Kg
			A	B	C	D	E	F	G	H	I	L	Metric	Unc	

**SERIE 3000**

345	1/2"	AFS301	30,96	24,26	38,10	54	8,74	22,8	19	13	6,22	8,75	M8x30	5/16x1"1/4	0,12
345	3/4"	AFS302	38,89	32,13	47,63	65	11,13	25,9	22	14	6,22	10,75	M10x35	3/8x1"1/2	0,16
345	1"	AFS303	45,24	38,48	52,37	70	13,08	29,2	24	16	7,49	10,75	M10x35	3/8x1"1/2	0,22
276	1"1/4	AFS304	51,59	43,69	58,72	79	15,09	36,3	22	14	7,49	12,00	M10x35	—	0,30
276	1"1/4	AFS304L1075	51,59	43,69	58,72	79	15,09	36,3	22	14	7,49	10,75	M10x35	—	0,30
276	1"1/4	AFS304L1275	51,59	43,69	58,72	79	15,09	36,3	22	14	7,49	12,75	M12x35	—	0,30
207	1"1/2	AFS305	61,09	50,80	69,85	94	17,86	41,1	25	16	7,49	13,50	M12x35	—	0,43
207	1"1/2	AFS305L1475	61,09	50,80	69,85	94	17,86	41,1	25	16	7,49	14,75	M14x45	—	0,43
207	2"	AFS306	72,24	62,74	77,77	102	21,44	48,2	26	16	9,02	13,50	M12x35	—	0,56
207	2"	AFS306L1475	72,24	62,74	77,77	102	21,44	48,2	26	16	9,02	14,75	M14x45	—	0,54
172	2"1/2	AFS307	84,94	74,93	88,90	114	25,40	54,1	38	19	9,02	13,50	M12x40	1/2x1"3/4	0,74
172	2"1/2	AFS307L1475	84,94	74,93	88,90	114	25,40	54,1	38	19	9,02	14,75	M14x45	—	0,74
138	3"	AFS308	102,39	90,93	106,38	135	30,96	65,3	41	22	9,02	16,75	M16x50	5/8x2"	1,30
34	3"1/2	AFS309	115,10	102,36	120,65	152	34,92	69,5	28	22	10,72	17,00	M16x50	5/8x2"	1,27
34	4"	AFS310	127,79	115,06	130,18	162	38,88	76,0	35	25	10,72	17,00	M16x50	5/8x2"	1,65
34	5"	AFS311	153,19	140,46	152,40	184	46,04	90,0	41	28	10,72	17,00	M16x50	5/8x2"	2,50

**SERIE 6000**

414	1/2"	AFS601	32,54	24,64	40,49	56	9,12	23,6	22	16	7,24	8,75	M8x30	5/16x1"1/4	0,16
414	3/4"	AFS602	42,06	32,51	50,80	71	11,91	30,0	28	19	8,26	11,00	M10x35	3/8x1"1/2	0,34
414	1"	AFS603	48,41	38,86	57,15	81	13,89	34,8	33	24	9,02	13,00	M12x45	—	0,51
414	1"	AFS603L12	48,41	38,86	57,15	81	13,89	34,8	33	24	9,02	12,00	—	7/16x1"3/4	0,51
414	1"1/4	AFS604	54,76	44,45	66,68	95	15,88	38,6	38	27	9,78	15,00	M14x45	—	0,80
414	1"1/4	AFS604L13	54,76	44,45	66,68	95	15,88	38,6	38	27	9,78	13,50	M12x45	1/2x1"3/4	0,80
414	1"1/2	AFS605	64,29	51,56	79,38	113	18,26	47,5	43	30	12,07	17,00	M16x50	5/8x2"	1,44
414	2"	AFS606	80,16	67,56	96,82	133	22,23	56,9	52	37	12,07	21,00	M20x70	3/4x2"1/2	2,10

DESIGNAZIONE PER ORDINE DESIGNATION FOR ORDER	Materiale / Material	
	ST52.3	AISI 316L
Solo coppia semiflanguia Only pair cut split flange	<b>AFS...</b>	<b>AFX...</b>
Coppia semiflanguia completa di viti metriche, grower e o-ring Pair cut split flange complete of metric screws, grower type washers and o-ring	<b>AFS...M</b>	<b>AFX...M</b>
Coppia semiflanguia completa di viti unc, grower e o-ring Pair cut split flange complete of unc screws, grower type washers and o-ring	<b>AFS...U</b>	<b>AFX...U</b>

**NOTE / NOTES**

**QUESTO PRODOTTO E' VENDUTO A COPPIE  
THIS PRODUCT IS SOLD BY PAIRS**

set viti unc disponibili solo in acciaio al carbonio.  
unc screws set available only in carbon steel.

Rivestimento superficiale: zincatura.  
Superficial coating: zinking.



## SEMIFLANGE INTERE

### UNCUT SPLIT FLANGES

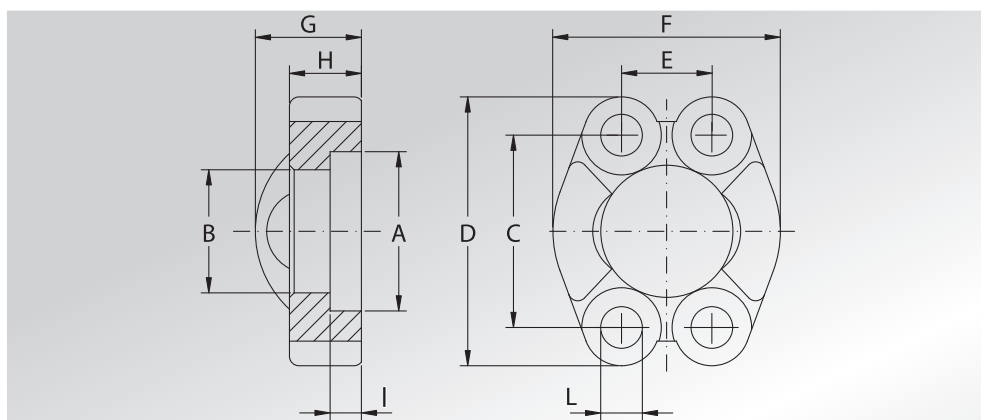

Pressione max di esercizio raccomandata Kg/cm <sup>2</sup>	Grandezza	Tipo	Dimensioni										Viti		Peso Kg
Maximum recommended working pressure Kg/cm <sup>2</sup>	Size	Type	Dimensions										Screws		Weight Kg
			A	B	C	D	E	F	G	H	I	L	Metric	Unc	

#### SERIE 3000

345	1/2"	AFSI301	30,96	24,26	38,10	54	17,48	45,6	19	13	6,22	8,75	M8x30	5/16x1"1/4	0,12
345	3/4"	AFSI302	38,89	32,13	47,63	65	22,23	51,8	22	14	6,22	10,75	M10x35	3/8x1"1/2	0,16
345	1"	AFSI303	45,24	38,48	52,37	70	26,19	58,4	24	16	7,49	10,75	M10x35	3/8x1"1/2	0,22
276	1"1/4	AFSI304	51,59	43,69	58,72	79	30,18	72,6	22	14	7,49	12,00	M10x35	—	0,30
276	1"1/4	AFSI304L1075	51,59	43,69	58,72	79	30,18	72,6	22	14	7,49	10,75	M10x35	—	0,30
276	1"1/4	AFSI304L1275	51,59	43,69	58,72	79	30,18	72,6	22	14	7,49	12,75	M12x35	—	0,30
207	1"1/2	AFSI305	61,09	50,80	69,85	94	35,71	82,2	25	16	7,49	13,50	M12x35	—	0,43
207	1"1/2	AFSI305L1475	61,09	50,80	69,85	94	35,71	82,2	25	16	7,49	14,75	M14x45	—	0,43
207	2"	AFSI306	72,24	62,74	77,77	102	42,88	96,4	26	16	9,02	13,50	M12x35	—	0,56
207	2"	AFSI306L1475	72,24	62,74	77,77	102	42,88	96,4	26	16	9,02	14,75	M14x45	—	0,54
172	2"1/2	AFSI307	84,94	74,93	88,90	114	50,80	108,2	38	19	9,02	13,50	M12x40	1/2x1"3/4	0,74
172	2"1/2	AFSI307L1475	84,94	74,93	88,90	114	50,80	108,2	38	19	9,02	14,75	M14x45	—	0,74
138	3"	AFSI308	102,39	90,93	106,38	135	61,93	130,6	41	22	9,02	16,75	M16x50	5/8x2"	1,30
34	3"1/2	AFSI309	115,10	102,36	120,65	152	69,85	139,0	28	22	10,72	17,00	M16x50	5/8x2"	1,27
34	4"	AFSI310	127,79	115,06	130,18	162	77,77	152,0	35	25	10,72	17,00	M16x50	5/8x2"	1,65
34	5"	AFSI311	153,19	140,46	152,40	184	92,08	180,0	41	28	10,72	17,00	M16x50	5/8x2"	2,50

#### SERIE 6000

414	1/2"	AFSI601	32,54	24,64	40,49	56	18,24	47,2	22	16	7,24	8,75	M8x30	5/16x1"1/4	0,16
414	3/4"	AFSI602	42,06	32,51	50,80	71	23,80	60,0	28	19	8,26	11,00	M10x35	3/8x1"1/2	0,34
414	1"	AFSI603	48,41	38,86	57,15	81	27,76	69,6	33	24	9,02	13,00	M12x45	—	0,51
414	1"	AFSI603L12	48,41	38,86	57,15	81	27,76	69,6	33	24	9,02	12,00	—	7/16x1"3/4	0,51
414	1"1/4	AFSI604	54,76	44,45	66,68	95	31,75	77,2	38	27	9,78	15,00	M14x45	—	0,80
414	1"1/4	AFSI604L13	54,76	44,45	66,68	95	31,75	77,2	38	27	9,78	13,50	M12x45	1/2x1"3/4	0,80
414	1"1/2	AFSI605	64,29	51,56	79,38	113	36,50	95,0	43	30	12,07	17,00	M16x50	5/8x2"	1,44
414	2"	AFSI606	80,16	67,56	96,82	133	44,45	113,8	52	37	12,07	21,00	M20x70	3/4x2"1/2	2,10



## SEMIFLANGE PIATTE INTERE NON ZINCATE

### UNCUT FLAT SPLIT FLANGES NOT ZINKED

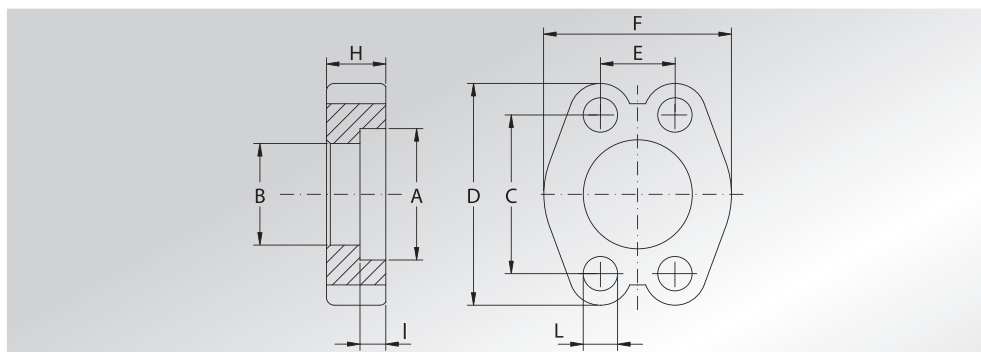

414	2"1/2"	AFPI607	89,50	108,50	123,80	180	58,70	152	—	45	20	26	M24x80	—	—
414	3"	AFPI608 (•)	114,50	132,50	152,40	208	71,40	178	—	55	25	33	M30x100	—	—

DESIGNAZIONE PER ORDINE DESIGNATION FOR ORDER	Materiale / Material	
	ST52.3	AISI 316L
Solo semiflangia intera / Only uncut split flange	<b>AFSI...</b>	<b>AFXI...</b>
Semiflangia intera completa di viti metriche, grower e o-ring Uncut split flange complete of metric screws, grower type washers and o-ring	<b>AFSI...M</b>	<b>AFXI...M</b>
Semiflangia intera completa di viti unc, grower e o-ring Uncut split flange complete of unc screws, grower type washers and o-ring	<b>AFSI...U</b>	<b>AFXI...U</b>

#### NOTE / NOTES

Rivestimento superficiale: zincatura.  
Superficial coating: zinking.

set viti unc disponibili solo in acciaio al carbonio.  
unc screws set available only in carbon steel.

(•) Minimo 20 pezzi  
(•) Minimum 20 pieces

**SEMIFLANGE  
INTERE CON FORI  
DI FISSAGGIO  
FILETTATI METRICI**



**UNCUT SPLIT  
FLANGES WITH  
METRIC THREADED  
FIXING HOLES**

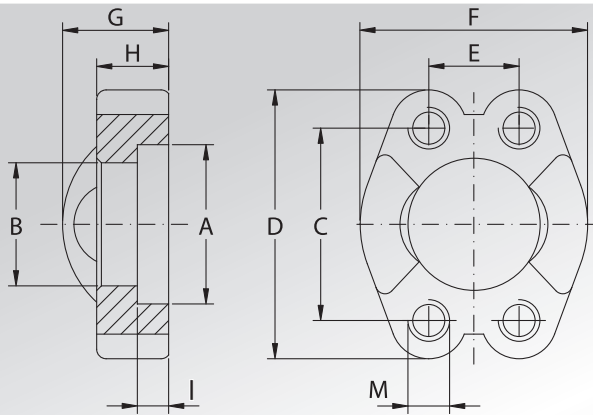

Pressione max di esercizio raccomandata Kg/cm <sup>2</sup>	Grandezza	Tipo	Dimensioni										Peso Kg
Maximum recommended working pressure Kg/cm <sup>2</sup>	Size	Type	Dimensions										Weight Kg
			A	B	C	D	E	F	G	H	I	M	

**SERIE 3000**

345	1/2"	GFSI301	30,96	24,26	38,10	54	17,48	45,6	19	13	6,22	M8	0,12
345	3/4"	GFSI302	38,89	32,13	47,63	65	22,23	51,8	22	14	6,22	M10	0,16
345	1"	GFSI303	45,24	38,48	52,37	70	26,19	58,4	24	16	7,49	M10	0,22
276	1"1/4	GFSI304	51,59	43,69	58,72	79	30,18	72,6	22	14	7,49	M10	0,30
207	1"1/2	GFSI305	61,09	50,80	69,85	94	35,71	82,2	25	16	7,49	M12	0,43
207	2"	GFSI306	72,24	62,74	77,77	102	42,88	96,4	26	16	9,02	M12	0,56
172	2"1/2	GFSI307	84,94	74,93	88,90	114	50,80	108,2	38	19	9,02	M12	0,74
138	3"	GFSI308	102,39	90,93	106,38	135	61,93	130,6	41	22	9,02	M16	1,30
34	3"1/2	GFSI309	115,10	102,36	120,65	152	69,85	139,0	28	22	10,72	M16	1,27
34	4"	GFSI310	127,79	115,06	130,18	162	77,77	152,0	35	25	10,72	M16	1,65
34	5"	GFSI311	153,19	140,46	152,40	184	92,08	180,0	41	28	10,72	M16	2,50

**SERIE 6000**

414	1/2"	GFSI601	32,54	24,64	40,49	56	18,24	47,2	22	16	7,24	M8	0,16
414	3/4"	GFSI602	42,06	32,51	50,80	71	23,80	60,0	28	19	8,26	M10	0,34
414	1"	GFSI603	48,41	38,86	57,15	81	27,76	69,6	33	24	9,02	M12	0,51
414	1"1/4	GFSI604	54,76	44,45	66,68	95	31,75	77,2	38	27	9,78	M14	0,80
414	1"1/2	GFSI605	64,29	51,56	79,38	113	36,50	95,0	43	30	12,07	M16	1,44
414	2"	GFSI606	80,16	67,56	96,82	133	44,45	113,8	52	37	12,07	M20	2,10

**DESIGNAZIONE PER ORDINE  
DESIGNATION FOR ORDER**

Semiflangua intera con fori di fissaggio metrici  
Uncut split flange with metric threaded fixing holes

**Materiale / Material**

**ST52.3**

**AISI 316L**

**GFSI...**

**GFXI...**

**NOTE / NOTES**

Rivestimento superficiale: zincatura.  
Superficial coating: zinking.



## SEMIFLANGE INTERE CON FORI DI FISSAGGIO FILETTATI UNC

## UNCUT SPLIT FLANGES WITH UNC THREADED FIXING HOLES

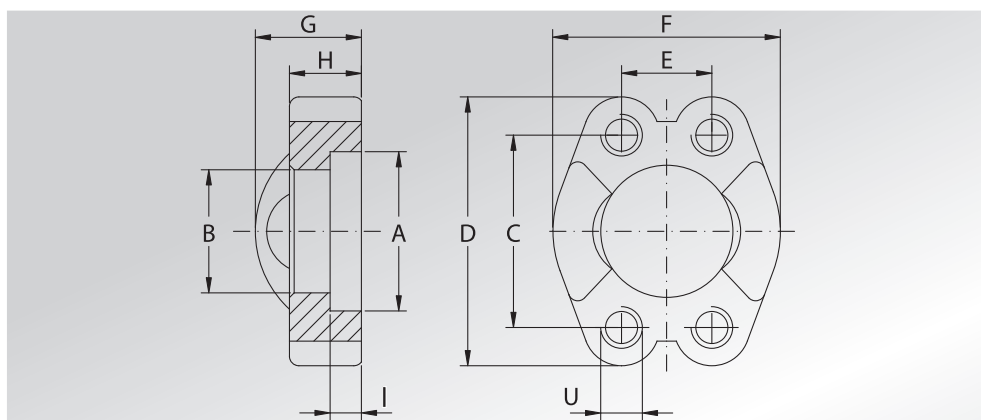

Pressione max di esercizio raccomandata Kg/cm <sup>2</sup>	Grandezza	Tipo	Dimensioni										Peso Kg
Maximum recommended working pressure Kg/cm <sup>2</sup>	Size	Type	Dimensions										Weight Kg
			A	B	C	D	E	F	G	H	I	U	

### SERIE 3000

345	1/2"	GFSI301U	30,96	24,26	38,10	54	17,48	45,6	19	13	6,22	5/16	0,12
345	3/4"	GFSI302U	38,89	32,13	47,63	65	22,23	51,8	22	14	6,22	3/8	0,16
345	1"	GFSI303U	45,24	38,48	52,37	70	26,19	58,4	24	16	7,49	3/8	0,22
276	1"1/4	GFSI304U	51,59	43,69	58,72	79	30,18	72,6	22	14	7,49	7/16	0,30
207	1"1/2	GFSI305U	61,09	50,80	69,85	94	35,71	82,2	25	16	7,49	1/2	0,43
207	2"	GFSI306U	72,24	62,74	77,77	102	42,88	96,4	26	16	9,02	1/2	0,56
172	2"1/2	GFSI307U	84,94	74,93	88,90	114	50,80	108,2	38	19	9,02	1/2	0,74
138	3"	GFSI308U	102,39	90,93	106,38	135	61,93	130,6	41	22	9,02	5/8	1,30
34	3"1/2	GFSI309U	115,10	102,36	120,65	152	69,85	139,0	28	22	10,72	5/8	1,27
34	4"	GFSI310U	127,79	115,06	130,18	162	77,77	152,0	35	25	10,72	5/8	1,65
34	5"	GFSI311U	153,19	140,46	152,40	184	92,08	180,0	41	28	10,72	5/8	2,50

### SERIE 6000

414	1/2"	GFSI601U	32,54	24,64	40,49	56	18,24	47,2	22	16	7,24	5/16	0,16
414	3/4"	GFSI602U	42,06	32,51	50,80	71	23,80	60,0	28	19	8,26	3/8	0,34
414	1"	GFSI603U	48,41	38,86	57,15	81	27,76	69,6	33	24	9,02	7/16	0,51
414	1"1/4	GFSI604U	54,76	44,45	66,68	95	31,75	77,2	38	27	9,78	1/2	0,80
414	1"1/2	GFSI605U	64,29	51,56	79,38	113	36,50	95,0	43	30	12,07	5/8	1,44
414	2"	GFSI606U	80,16	67,56	96,82	133	44,45	113,8	52	37	12,07	3/4	2,10

#### DESIGNAZIONE PER ORDINE DESIGNATION FOR ORDER

Semiflangua intera con fori di fissaggio unc  
Uncut split flange with unc threaded fixing holes

#### Materiale / Material

ST52.3      AISI 316L

GFSI...U

GFXI...U

#### NOTE / NOTES

Rivestimento superficiale: zincatura.  
Superficial coating: zinking.



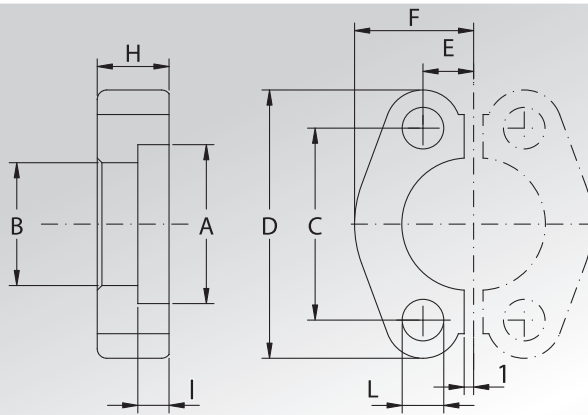

Pressione max di esercizio raccomandata Kg/cm <sup>2</sup>	Grandezza	Tipo	Dimensioni									Viti		Peso Kg
Maximum recommended working pressure Kg/cm <sup>2</sup>	Size	Type	Dimensions									Screws		Weight Kg
			A	B	C	D	E	F	H	I	L	Metric	Unc	

**SERIE 3000**

345	1/2"	AFP301	30,96	24,26	38,10	54	8,74	22,8	13	6,22	8,75	M8x30	5/16x1"1/4	0,10
345	3/4"	AFP302	38,89	32,13	47,63	65	11,13	25,9	14	6,22	10,75	M10x35	3/8x1"1/2	0,15
345	1"	AFP303	45,24	38,48	52,37	70	13,08	29,2	16	7,49	10,75	M10x35	3/8x1"1/2	0,20
276	1"1/4	AFP304	51,59	43,69	58,72	79	15,09	36,3	16	7,49	12,00	M10x35	—	0,27
276	1"1/4	AFP304L1075	51,59	43,69	58,72	79	15,09	36,3	16	7,49	10,75	M10x35	—	0,27
276	1"1/4	AFP304L1275	51,59	43,69	58,72	79	15,09	36,3	16	7,49	12,75	M12x35	—	0,27
207	1"1/2	AFP305	61,09	50,80	69,85	94	17,86	41,1	16	7,49	13,50	M12x35	—	0,39
207	1"1/2	AFP305L1475	61,09	50,80	69,85	94	17,86	41,1	16	7,49	14,75	M14x45	—	0,39
207	2"	AFP306	72,24	62,74	77,77	102	21,44	48,2	16	9,02	13,50	M12x35	—	0,44
207	2"	AFP306L1475	72,24	62,74	77,77	102	21,44	48,2	16	9,02	14,75	M14x45	—	0,50

**SERIE 6000**

414	1/2"	AFP601	32,54	24,64	40,49	56	9,12	23,6	16	7,24	8,75	M8x30	5/16x1"1/4	0,16
414	3/4"	AFP602	42,06	32,51	50,80	71	11,91	30,0	19	8,26	11,00	M10x35	3/8x1"1/2	0,28
414	1"	AFP603	48,41	38,86	57,15	81	13,89	34,8	24	9,02	13,00	M12x45	—	0,43
414	1"1/4	AFP604	54,76	44,45	66,68	95	15,88	38,6	27	9,78	15,00	M14x45	—	0,65
414	1"1/4	AFP604L13	54,76	44,45	66,68	95	15,88	38,6	27	9,78	13,50	M12x45	1/2x1"3/4	0,65
414	1"1/2	AFP605	64,29	51,56	79,38	113	18,26	47,5	30	12,07	17,00	M16x50	5/8x2"	1,23
414	2"	AFP606	80,16	67,56	96,82	133	22,23	56,9	37	12,07	21,00	M20x70	3/4x2"1/2	2,02
414	2"1/2	AFP607 (*)	89,50	108,50	123,80	180	29,35	76,0	45	20,00	26,00	M24x80	—	—
414	3"	AFP608 (*) (•)	114,50	132,50	154,40	208	35,70	89,0	55	25,00	33,00	M30x100	—	—

**DESIGNAZIONE PER ORDINE  
DESIGNATION FOR ORDER**

Solo coppia semiflangia piatta tagliata  
Only pair flat cut split flange

Coppia semiflangia piatta completa di viti metriche, grower e o-ring  
Pair cut flat split flange complete of metric screws, grower type washers and o-ring

Coppia semiflangia piatta completa di viti unc, grower e o-ring  
Pair cut flat split flange complete of unc screws, grower type washers and o-ring

**Materiale / Material**

**ST52.3**

**AFP...**

**AFP...M**

**AFP...U**

**NOTE / NOTES**

**QUESTO PRODOTTO E' VENDUTO A COPPIE  
THIS PRODUCT IS SOLD BY PAIRS**

Rivestimento superficiale: zincatura.  
Superficial coating: zinking.

(•) Minimo 20 coppie.  
(•) Minimum 20 pairs.

(\*) Non zincato.  
(•) Not zinked.



## CODOLI A SALDARE DI TESTA PER TUBO METRICO

## WELD ON ADAPTERS FOR METRIC TUBE

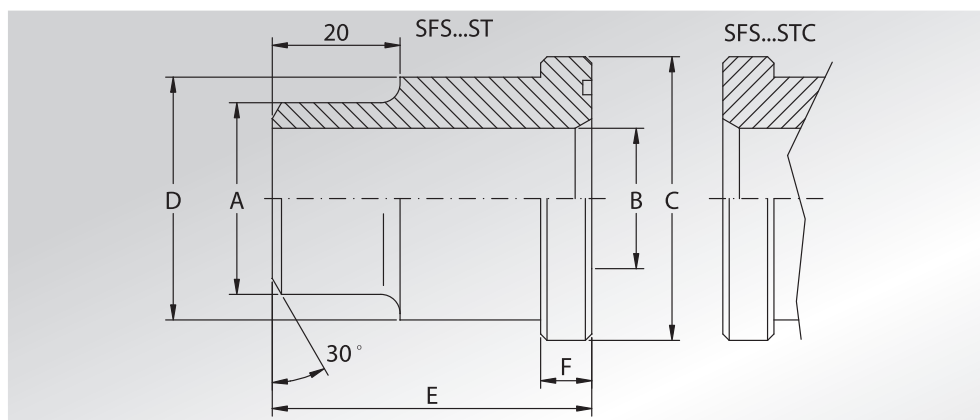

Pressione max di esercizio raccomandata Kg/cm <sup>2</sup>	Grandezza	Tipo	Dimensioni						Or tipo	Peso Kg
Maximum recommended working pressure Kg/cm <sup>2</sup>	Size	Type	Dimensions						Or type	Weight Kg
			A	B	C	D	E	F		

### SERIE 3000

345	1/2"	SFS301ST	16	12	30,2	24	41	6,73	4075	0,08
345	3/4"	SFS302ST	25	19	38,1	32	50	6,73	4100	0,16
345	1"	SFS303ST	30	22	44,4	38	50	8,00	4131	0,23
276	1"1/4	SFS304ST	38	28	50,8	43	55	8,00	4150	0,30
207	1"1/2	SFS305ST	45	35	60,3	50	57	8,00	4187	0,40
207	2"	SFS306ST	60	50	71,4	62	57	9,53	4225	0,50
172	2"1/2	SFS307ST	70	55	84,1	74	58	9,53	4275	0,80
138	3"	SFS308ST	80	68	101,6	90	60	9,53	4337	1,10
34	3"1/2	SFS309ST	100	89	114,3	102	80	11,20	4387	1,40
34	4"	SFS310ST	114,3	99	127,0	114,3	80	11,20	4437	1,75
34	5"	SFS311ST	139,7	120	152,4	139,7	80	11,20	4537	2,62

### SERIE 6000

250	1/2"	SFS601ST	16	12	31,8	24	34	7,75	4075	0,08
315	3/4"	SFS602ST	25	18	41,3	32	38	8,76	4100	0,15
250	1"	SFS603ST	30	22	47,6	38	40	9,53	4131	0,23
290	1"1/4	SFS604ST	38	27	54,0	44	45	10,29	4150	0,30
300	1"1/2	SFS605ST	45	32	63,5	51	50	12,57	4187	0,50
300	2"	SFS606ST	60	45	79,4	67	58	12,57	4225	0,80

PER QUESTA TIPOLOGIA DI PRODOTTO, VERIFICATE SEMPRE SE LA QUOTA "A" E "B" CORRISPONDE ALLA SCHEDULA DEL VOSTRO TUBO

FOR THIS KIND OF PRODUCT, PLEASE ALWAYS VERIFY IF DIMENSION "A" AND "B" CORRESPOND TO THE SCHEDULE OF YOUR TUBE

DESIGNAZIONE PER ORDINE DESIGNATION FOR ORDER	Materiale / Material	
	A105 o similare (or similar)	AISI 316L
Codolo con sede o-ring Adapter with o-ring groove	<b>SFS...ST</b>	<b>SFX...ST</b>
Codolo senza sede o-ring Adapter without o-ring groove	<b>SFS...STC</b>	<b>SFX...STC</b>

NOTE / NOTES

**CODOLI  
A SALDARE DI  
TESTA  
PER TUBO GAS**



**WELD  
ON ADAPTERS  
FOR BSP TUBE**

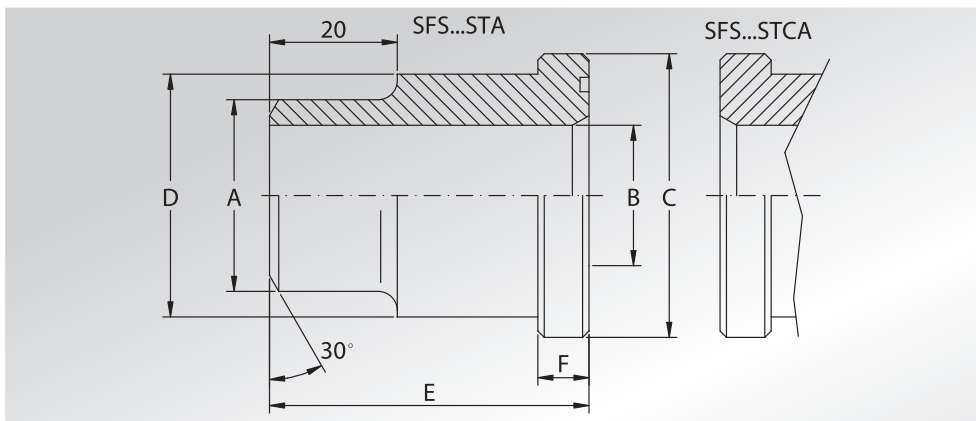

Pressione max di esercizio raccomandata Kg/cm <sup>2</sup>	Grandezza	Tipo	Dimensioni						Or tipo	Peso Kg
Maximum recommended working pressure Kg/cm <sup>2</sup>	Size	Type	Dimensions						Or type	Weight Kg
			A	B	C	D	E	F		

**SERIE 3000**

345	1/2"	SFS301STA21	21,5	13	30,2	24	41	6,73	4075	0,08
345	3/4"	SFS302STA28	28,0	19	38,1	32	50	6,73	4100	0,16
345	1"	SFS303STA34	34,0	25	44,4	38	50	8,00	4131	0,23
276	1"1/4	SFS304STA42	42,8	32	50,8	43	55	8,00	4150	0,30
207	1"1/2	SFS305STA48	48,6	38	60,3	50	57	8,00	4187	0,40
207	2"	SFS306STA61	61,0	51	71,4	62	57	9,53	4225	0,50

**SERIE 6000**

414	1/2"	SFS601STA21	21,5	13	31,8	24	34	7,75	4075	0,08
414	3/4"	SFS602STA28	28,0	19	41,3	32	38	8,76	4100	0,15
414	1"	SFS603STA34	34,0	25	47,6	38	40	9,53	4131	0,23
375	1"1/4	SFS604STA42	42,8	32	54,0	44	45	10,29	4150	0,30
320	1"1/2	SFS605STA48	48,6	38	63,5	51	50	12,57	4187	0,50
250	2"	SFS606STA61	61,0	51	79,4	67	58	12,57	4225	0,80

PER QUESTA TIPOLOGIA DI PRODOTTO, VERIFICATE SEMPRE SE LA QUOTA "A" E "B" CORRISPONDE ALLA SCHEDULA DEL VOSTRO TUBO

FOR THIS KIND OF PRODUCT, PLEASE ALWAYS VERIFY IF DIMENSION "A" AND "B" CORRESPOND TO THE SCHEDULE OF YOUR TUBE

DESIGNAZIONE PER ORDINE DESIGNATION FOR ORDER	Materiale / Material	
	A105 o similare (or similar)	AISI 316L
Codolo con sede o-ring Adapter with o-ring groove	<b>SFS...STA</b>	<b>SFX...STA</b>
Codolo senza sede o-ring Adapter without o-ring groove	<b>SFS...STCA</b>	<b>SFX...STCA</b>

NOTE / NOTES



## CODOLI FILETTATI GAS CONICO

### BSP TAPERED THREADED ADAPTERS

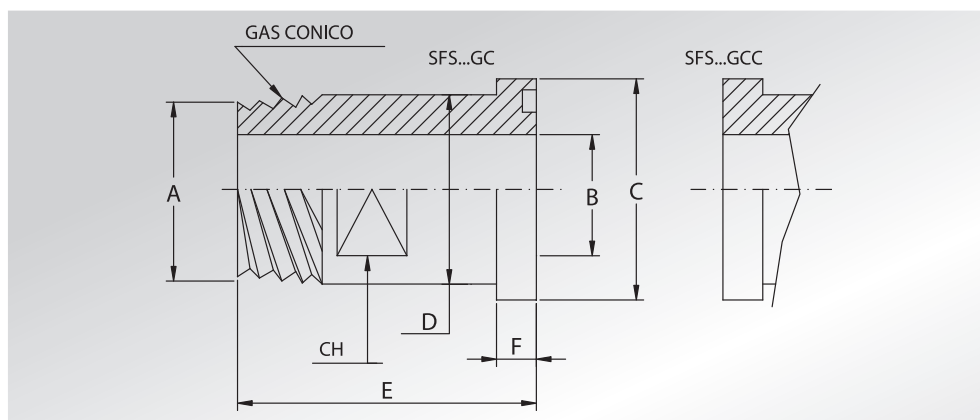

Pressione max di esercizio raccomandata Kg/cm <sup>2</sup>	Grandezza	Tipo	Dimensioni							Or tipo	Peso Kg
Maximum recommended working pressure Kg/cm <sup>2</sup>	Size	Type	Dimensions							Or type	Weight Kg
			A	B	C	D	E	F	CH		

#### SERIE 3000

345	1/2"	SFS301GC	1/2"	12	30,2	24	50	6,73	19	4075	0,08
345	3/4"	SFS302GC	3/4"	17	38,1	32	55	6,73	27	4100	0,16
345	1"	SFS303GC	1"	22	44,4	38	60	8,00	32	4131	0,23
276	1"1/4	SFS304GC	1"1/4	27	50,8	43	65	8,00	41	4150	0,30
207	1"1/2	SFS305GC	1"1/2	32	60,3	50	70	8,00	46	4187	0,40
207	2"	SFS306GC	2"	40	71,4	62	75	9,53	55	4225	0,50

#### SERIE 6000

414	1/2"	SFS601GC	1/2"	12	31,8	24	50	7,75	19	4075	0,08
414	3/4"	SFS602GC	3/4"	17	41,3	32	60	8,76	26	4100	0,15
414	1"	SFS603GC	1"	22	47,6	38	70	9,53	32	4131	0,23
414	1"1/4	SFS604GC	1"1/4	27	54,0	44	75	10,29	36	4150	0,30
414	1"1/2	SFS605GC	1"1/2	32	63,5	51	80	12,57	41	4187	0,50
414	2"	SFS606GC	2"	40	79,4	67	90	12,57	55	4225	0,80

DESIGNAZIONE PER ORDINE DESIGNATION FOR ORDER	Materiale / Material	
	A105 o similare (or similar)	AISI 316L
Codolo con sede o-ring Adapter with o-ring groove	<b>SFS...GC</b>	<b>SFX...GC</b>
Codolo senza sede o-ring Adapter without o-ring groove	<b>SFS...GCC</b>	<b>SFX...GCC</b>

#### NOTE / NOTES

Rivestimento superficiale: zincatura.  
Superficial coating: zinking.

**CODOLI FILETTATI  
METRICI ATTACCO  
DIN 3901- 3902**



**DIN 3901 - 3902  
METRIC THREADED  
ADAPTERS**

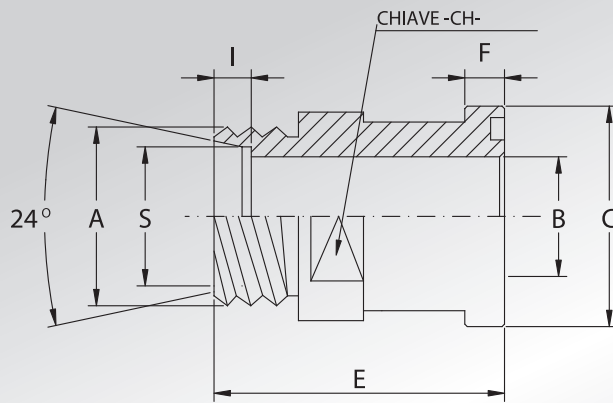

Pressione max di esercizio raccomandata Kg/cm <sup>2</sup>	Grandezza	Tipo	Dimensioni								Or tipo	Peso Kg
Maximum recommended working pressure Kg/cm <sup>2</sup>	Size	Type	Dimensions								Or type	Weight Kg
			A	B	C	E	F	I	S	CH		
<b>SERIE 3000</b>												
315	1/2"	SFCE301L15	M22x1,5	12	30,2	48	6,73	7,0	15	24	4075	0,13
350	1/2"	SFCE301S16	M24x1,5	12	30,2	50	6,73	8,5	16	24	4075	0,14
315	3/4"	SFCE302L18	M26x1,5	15	38,1	53	6,73	7,5	18	30	4100	0,21
160	3/4"	SFCE302L22	M30x2	19	38,1	53	6,73	7,5	22	30	4100	0,21
350	3/4"	SFCE302S20	M30x2	16	38,1	57	6,73	10,5	20	30	4100	0,24
350	3/4"	SFCE302S25	M36x2	17	38,1	57	6,73	12,0	25	30	4100	0,26
160	1"	SFCE303L28	M36x2	24	44,4	54	8,00	7,5	28	36	4131	0,28
350	1"	SFCE303S25	M36x2	20	44,4	58	8,00	12,0	25	36	4131	0,35
350	1"	SFCE303S30	M42x2	24	44,4	63	8,00	13,5	30	36	4131	0,37
160	1"1/4	SFCE304L28	M36x2	22	50,8	58	8,00	7,5	28	36	4150	0,43
160	1"1/4	SFCE304L35	M45x2	30	50,8	58	8,00	10,5	35	41	4150	0,34
280	1"1/4	SFCE304S25	M36x2	20	50,8	60	8,00	12,0	25	41	4150	0,44
280	1"1/4	SFCE304S30	M42x2	25	50,8	62	8,00	13,5	30	41	4150	0,44
280	1"1/4	SFCE304S38	M52x2	28	50,8	66	8,00	16,0	38	41	4150	0,53
160	1"1/2	SFCE305L42	M52x2	36	60,3	64	8,00	11,0	42	46	4187	0,49
210	1"1/2	SFCE305S38	M52x2	32	60,3	70	8,00	16,0	38	46	4187	0,63

**SERIE 6000**

400	1/2"	SFCE601S16	M24x1,5	12	31,8	53	7,75	8,5	16	24	4075	0,15
400	3/4"	SFCE602S16	M24x1,5	12	41,3	59	8,76	8,5	16	30	4100	0,28
400	3/4"	SFCE602S20	M30x2	16	41,3	61	8,76	10,5	20	30	4100	0,29
400	3/4"	SFCE602S25	M36x2	17	41,3	63	8,76	12,0	25	30	4100	0,31
400	3/4"	SFCE602S30	M42x2	18	41,3	64	8,76	13,5	30	36	4100	0,36
400	1"	SFCE603S25	M36x2	20	47,6	72	9,53	12,0	25	36	4131	0,46
400	1"	SFCE603S30	M42x2	24	47,6	74	9,53	13,5	30	36	4131	0,43
400	1"1/4	SFCE604S30	M42x2	25	54,0	79	10,29	13,5	30	41	4150	0,58
400	1"1/4	SFCE604S38	M52x2	30	54,0	83	10,29	16,0	38	46	4150	0,65
400	1"1/2	SFCE605S38	M52x2	30	63,5	89	12,57	16,0	38	46	4187	0,94

**DESIGNAZIONE PER ORDINE  
DESIGNATION FOR ORDER**

Codolo con sede o-ring  
Adapter with o-ring groove

**Materiale / Material**  
**A105 o similare (or similar)**

**SFCE...L/S**

**NOTE / NOTES**

Rivestimento superficiale: zincatura.  
Superficial coating: zinking.



## CODOLI FILETTATI GAS CILINDRICO DOPPIA SEDE O-RING

### BSP CYLINDRICAL THREADED ADAPTERS WITH DOUBLE O-RING SEAT

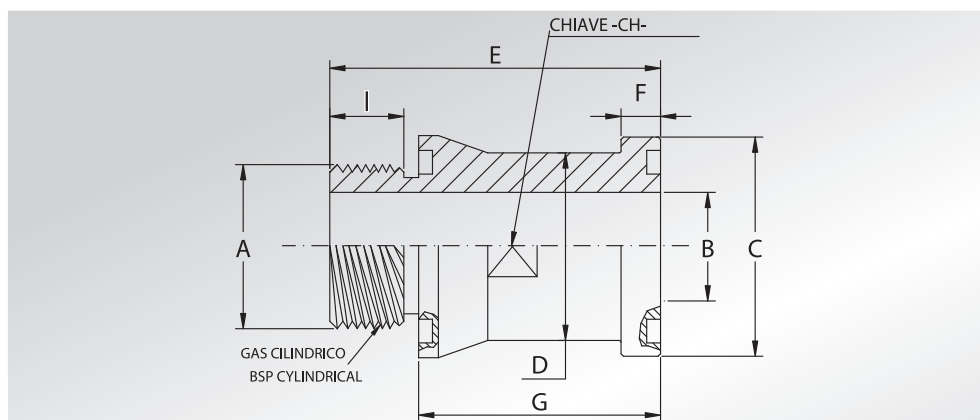

Pressione max di esercizio raccomandata Kg/cm <sup>2</sup>	Grandezza	Tipo	Dimensioni									Or tipo	Peso Kg
Maximum recommended working pressure Kg/cm <sup>2</sup>	Size	Type	Dimensions									Or type	Weight Kg
			A	B	C	D	E	F	G	I	CH		

#### SERIE 3000

345	1/2"	SFS301G20R	1/2"	8	30,2	24	50	6,73	35	12	22	4075	0,08
345	3/4"	SFS302G20R	3/4"	13	38,1	32	53	6,73	37	13	27	4100	0,16
345	1"	SFS303G20R	1"	20	44,4	38	67	8,00	49	15	36	4131	0,23
276	1"1/4	SFS304G20R	1"1/4	24	50,8	43	64	8,00	45	15	41	4150	0,30
207	1"1/2	SFS305G20R	1"1/2	30	60,3	49	72	8,00	50	18	46	4187	0,40
207	2"	SFS306G20R	2"	38	71,4	61	74	9,53	52	18	55	4225	0,50

#### SERIE 6000

414	1/2"	SFS601G20R	1/2"	8	31,8	24	50	7,75	35	12	22	4075	0,08
414	3/4"	SFS602G20R	3/4"	12	41,3	32	60	8,76	43	14	27	4100	0,15
414	1"	SFS603G20R	1"	19	47,6	38	70	9,53	52	15	36	4131	0,23
414	1"1/4	SFS604G20R	1"1/4	24	54,0	44	75	10,29	56	15	41	4150	0,30
414	1"1/2	SFS605G20R	1"1/2	28	63,5	51	82	12,57	60	18	46	4187	0,50
414	2"	SFS606G20R	2"	38	79,4	67	94	12,57	72	18	55	4225	0,80

#### DESIGNAZIONE PER ORDINE DESIGNATION FOR ORDER

Codolo filettato gas cilindrico con doppia sede o-ring  
BSP cylindrical adapter threaded with double o-ring seat

Materiale / Material	
A105 o similare (or similar)	AISI 316L

**SFS...G20R**

**SFX...G20R**

#### NOTE / NOTES

Rivestimento superficiale: zincatura.  
Superficial coating: zinking.

**CODOLI FILETTATI GAS  
CILINDRICO DOPPIA  
SEDE O-R LUNGO**



**BSP CYLINDRICAL  
THREADED LONG  
ADAPTERS WITH  
DOUBLE O-RING SEAT**

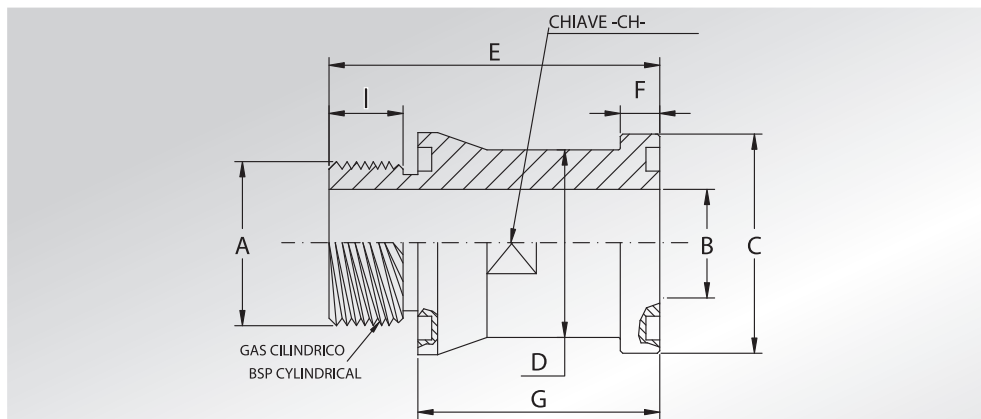

Pressione max di esercizio raccomandata Kg/cm <sup>2</sup>	Grandezza	Tipo	Dimensioni									Or tipo	Peso Kg
Maximum recommended working pressure Kg/cm <sup>2</sup>	Size	Type	Dimensions									Or type	Weight Kg
			A	B	C	D	E	F	G	I	CH		

**SERIE 3000**

345	1/2"	SFS301G20RG100	1/2"	8/12	30,2	24	115	6,73	100	12	22	4075
345	3/4"	SFS302G20RG100	3/4"	13	38,1	32	116	6,73	100	13	27	4100
345	1"	SFS303G20RG100	1"	20	44,4	38	118	8,00	100	15	36	4131
276	1"1/4	SFS304G20RG100	1"1/4	24	50,8	43	119	8,00	100	15	41	4150
207	1"1/2	SFS305G20RG100	1"1/2	30	60,3	49	122	8,00	100	18	46	4187
207	2"	SFS306G20RG100	2"	38	71,4	61	122	9,53	100	18	55	4225

**SERIE 6000**

414	1/2"	SFS601G20RG100	1/2"	8	31,8	24	115	7,75	100	12	22	4075
414	3/4"	SFS602G20RG100	3/4"	12	41,3	32	117	8,76	100	14	27	4100
414	1"	SFS603G20RG100	1"	19	47,6	38	118	9,53	100	15	36	4131
414	1"1/4	SFS604G20RG100	1"1/4	24	54,0	44	119	10,29	100	15	41	4150
414	1"1/2	SFS605G20RG100	1"1/2	28	63,5	51	122	12,57	100	18	46	4187
414	2"	SFS606G20RG100	2"	38	79,4	67	122	12,57	100	18	55	4225

**DESIGNAZIONE PER ORDINE  
DESIGNATION FOR ORDER**

Codolo filettato gas cilindrico con doppia sede o-ring lungo  
BSP cylindrical threaded long adapter with double o-ring seat

**Materiale / Material**

A105 o similare (or similar)

AISI 316L

**SFS...G20RG100**

**SFX...G20RG100**

**NOTE / NOTES**

Rivestimento superficiale: zincatura.  
Superficial coating: zinking.



## FLANGE OVALI CON FORO PASSANTE

## OVAL FLANGES WITH THROUGH HOLE

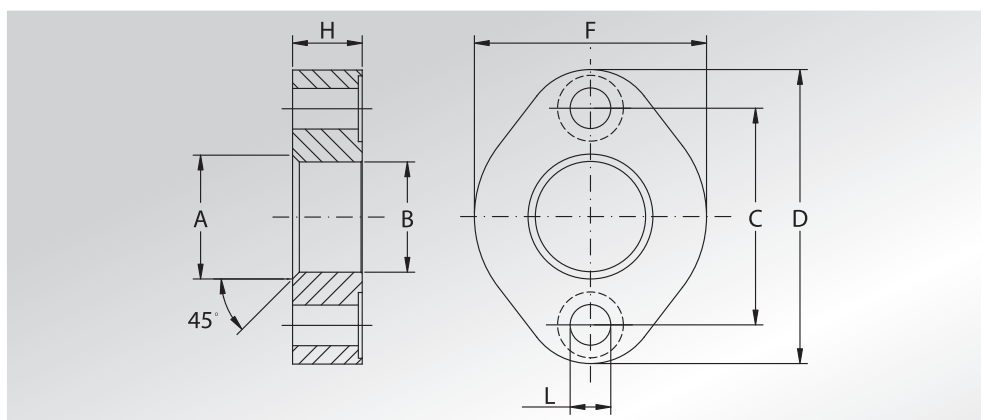

Pressione max di esercizio raccomandata Kg/cm <sup>2</sup>	Grandezza	Tipo	Dimensioni							Peso Kg
Maximum recommended working pressure Kg/cm <sup>2</sup>	Size	Type	Dimensions							Weight Kg
			A	B	C	D	F	H	L	

### SERIE 6000

414	1/2"	OVA401A20	22	20,5	44,40	60	48	14	8,5	0,18
414	1/2"	OVA401A23	27	24	44,40	60	48	14	8,5	0,18
414	3/4"	OVA402A27	32	28,5	56,10	76	60	18	10,5	0,34
414	1"	OVA403A37	43	37,5	63,60	88	70	22	12,5	0,52
414	1"1/4	OVA404A44	49	44	73,90	103	78	25	14,5	0,75

#### DESIGNAZIONE PER ORDINE DESIGNATION FOR ORDER

Solo flangia  
Only flange

#### Materiale / Material

ST52.3

OVA...A

#### NOTE / NOTES

Nella fornitura non sono previste viti di fissaggio.  
In our supply screws are not foreseen.



**TABELLA  
INFORMATIVA PER  
FORO  
CONTROLLO  
PRESSIONE**



**INFORMATIVE  
TABLE FOR  
HOLE TO CHECK  
PRESSURE**

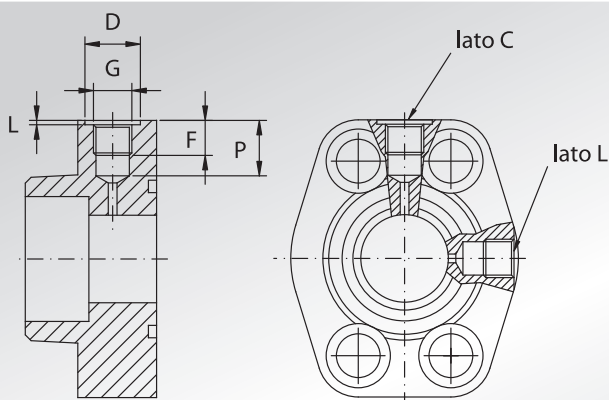

Tipo	Dimensioni				
Type	Dimensions				
	G	D	F	L	P
M10	M10x1	15	8,0	1,5	13,5
M12	M12x1,5	18	12,0	1,5	18,5
M14	M14x1,5	20	12,0	1,5	18,5
M16	M16x1,5	22	12,0	1,5	18,5
G18	G1/8	15	10,0	1,5	16,5
G14	G1/4	19	12,0	1,5	18,5
G38	G3/8	23	13,0	1,5	18,5

SAE	Tipo flangia	Grandezza foro eseguibile
Nom. Flange size in.	Flange type	Size hole which can be made on

**SERIE 3000**

1"	AFS/GFS102	M10 - G18
1"1/4	AFS/GFS104	M10 - M12 - G18
1"1/2	AFS/GFS106	M10 - M12 - M14 - G18 - G14
2"	AFS/GFS108	M10 - M12 - M14 - G18 - G14
2"1/2	AFS/GFS110	M10 - M12 - M14 - G18 - G14
3"	AFS/GFS112	M10 - M12 - M14 - M16 - G18 - G14 - G38
3"1/2	AFS/GFS114	M10 - M12 - M14 - M16 - G18 - G14 - G38
4"	AFS/GFS116	M10 - M12 - M14 - M16 - G18 - G14 - G38

**SERIE 6000**

1"	AFS/GFS403	M10 - M12 - G18
1"1/4	AFS/GFS404	M10 - M12 - G18
1"1/2	AFS/GFS405	M10 - M12 - M14 - G18 - G14
2"	AFS/GFS406	M10 - M12 - M14 - M16 - G18 - G14 - G38

DESIGNAZIONE PER ORDINE DESIGNATION FOR ORDER	Materiale / Material ST52.3
Flangia con foro lato corto Flange with hole short side	<b>AFS...(+M/G...C)</b>
Controflangia con foro lato corto Counter-flange with hole short side	<b>GFS...(+M/G...C)</b>
Flangia con foro lato lungo Flange with hole long side	<b>AFS...(+M/G...L)</b>
Controflangia con foro lato lungo Counter-flange with hole long side	<b>GFS...(+M/G...L)</b>



**NOTE**

**NOTES**

A series of horizontal grey lines providing a space for writing notes.

**TABELLE TECNICHE PER  
ASSIEMI GRUPPI SEMIFLANGE**

**TECHNICAL TABLES FOR  
SPLIT FLANGES GROUP ASSEMBLING**





## GRUPPO SEMIFLANGIA TAGLIATA

### GROUP CUT SPLIT FLANGE

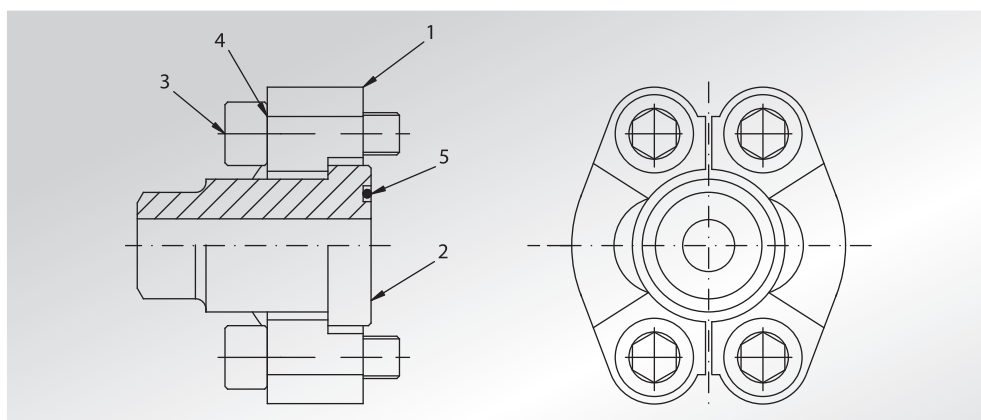

#### DISTINTA COMPONENTI - LIST OF COMPONENTS

#### AFS...STM

Pos.	Q.tà	Codice O.T.	Descrizione	Materiale	Riferimento
Pos.	Q.ty	O.T. code	Description	Material	Reference
5	1	OR....	O-RING	NBR	
4	4	GROWER..	GROWER	FE	
3	4	M..x...	VITE / SCREW	CL.8.8	
2	1	SFS...ST	CODOLO / ADAPTER	A105	PG. 58 / 59
1	1	AFS...	SEMIFLANGIA TAGLIATA / CUT SPLIT FLANGE	ST52.3	PG. 53



## DOPPIA SEMIFLANGIA TAGLIATA

### DOUBLE CUT SPLIT FLANGE

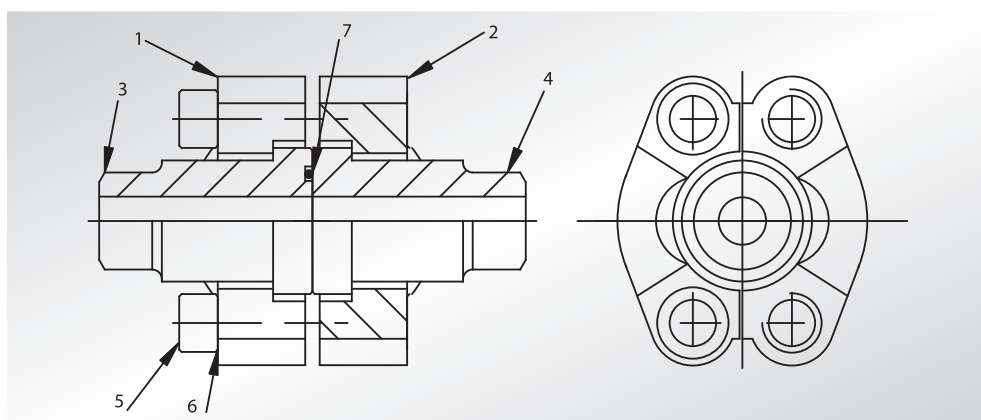

#### DISTINTA COMPONENTI - LIST OF COMPONENTS

#### DFS...STM

Pos.	Q.tà	Codice O.T.	Descrizione	Materiale	Riferimento
Pos.	Q.ty	O.T. code	Description	Material	Reference
7	1	OR....	O-RING	NBR	
6	4	GROWER..	GROWER	FE	
5	4	M..x...	VITE / SCREW	CL.8.8	
4	1	SFS...STC	CONTROCODOLO / COUNTER ADAPTER	A105	PG. 58 / 59
3	1	SFS...ST	CODOLO / ADAPTER	A105	PG. 58 / 59
2	1	GFSI...	SEMIFLANGIA FILETTATA / THREADED SPLIT FLANGE	ST52.3	PG. 55
1	1	AFS...	SEMIFLANGIA TAGLIATA / CUT SPLIT FLANGE	ST52.3	PG. 53

**GRUPPO  
SEMIFLANGIA  
INTERA**



**GROUP  
UNCUT SPLIT  
FLANGE**

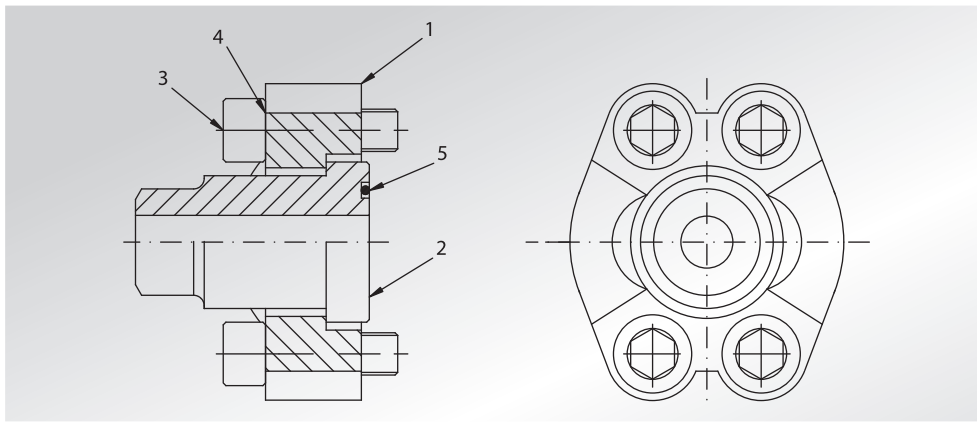

**DISTINTA COMPONENTI - LIST OF COMPONENTS**

**AFSL...STM**

Pos.	Q.tà	Codice O.T.	Descrizione	Materiale	Riferimento
Pos.	Q.ty	O.T. code	Description	Material	Reference
5	1	OR....	O-RING	NBR	
4	4	GROWER..	GROWER	FE	
3	4	M..x...	VITE / SCREW	CL.8.8	
2	1	SFS...ST	CODOLO / ADAPTER	A105	PG. 58 / 59
1	1	AFSL...	SEMIFLANGIA INTERA / UNCUT SPLIT FLANGE	ST52.3	PG. 54

**DOPPIA  
SEMIFLANGIA  
INTERA**



**DOUBLE  
UNCUT SPLIT  
FLANGE**

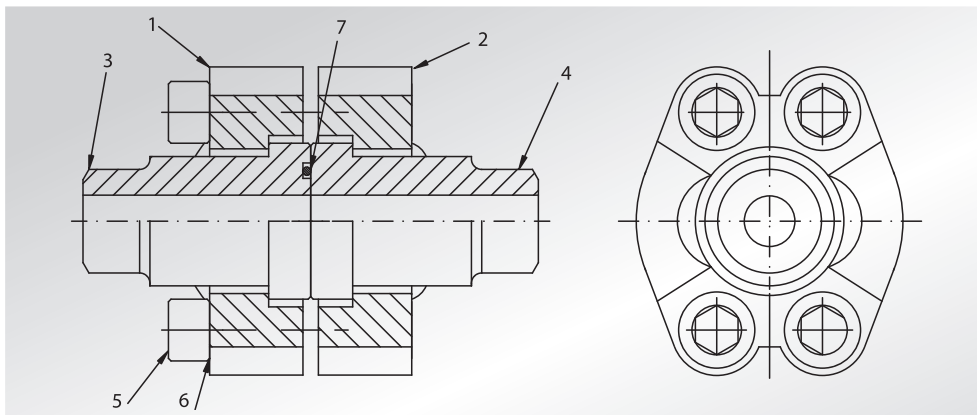

**DISTINTA COMPONENTI - LIST OF COMPONENTS**

**DFSL...STM**

Pos.	Q.tà	Codice O.T.	Descrizione	Materiale	Riferimento
Pos.	Q.ty	O.T. code	Description	Material	Reference
7	1	OR....	O-RING	NBR	
6	4	GROWER..	GROWER	FE	
5	4	M..x...	VITE / SCREW	CL.8.8	
4	1	SFS...STC	CONTROCODOLO / COUNTER ADAPTER	A105	PG. 58 / 59
3	1	SFS...ST	CODOLO / ADAPTER	A105	PG. 58 / 59
2	1	GFSI...	SEMIFLANGIA FILETTATA / THREADED SPLIT FLANGE	ST52.3	PG. 55
1	1	AFSL...	SEMIFLANGIA INTERA / UNCUT SPLIT FLANGE	ST52.3	PG. 54



**NOTE**

**NOTES**

A series of horizontal grey lines providing a space for writing notes.

**TABELLE TECNICHE PER  
RACCORDI POMPA**

***TECHNICAL TABLES FOR  
PUMPS CONNECTORS***





## RACCORDI POMPA TIPO RP

### STRAIGHT CONNECTORS RP TYPE

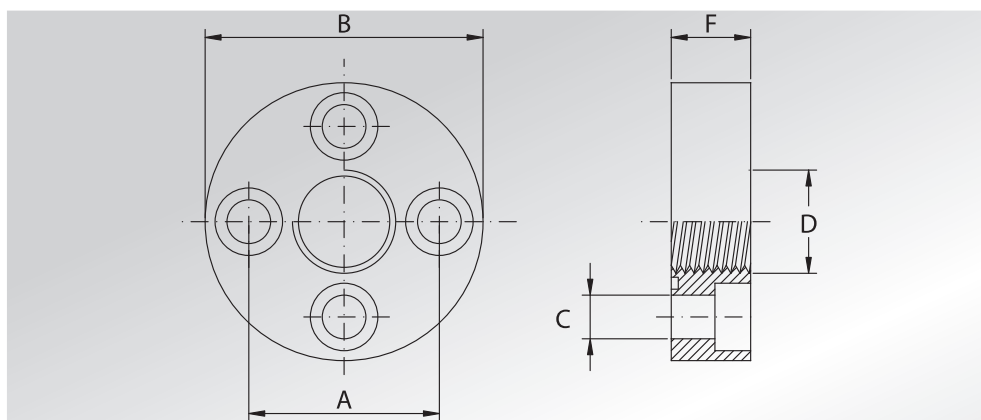

Pressione max di esercizio raccomandata Kg/cm <sup>2</sup>	Gruppo pompa	Tipo	Dimensioni					Viti Metriche	Or tipo	Peso Kg
Maximum recommended working pressure Kg/cm <sup>2</sup>	Pump group	Type	Dimensions					Metric screws	Or type	Weight Kg
			A	B	C	D	F			
300	1	RP1	30	45	6,5	3/8" GAS	11,5	M6x16	2075	0,10
300	2	RP2	40	58	8,5	1/2" GAS	14	M8x20	2100	0,20
300	3A	RP3A	51	76	10,5	3/4" GAS	18	M10x25	3125	0,46
300	3B	RP3B	56	76	10,5	3/4" GAS	18	M10x25	3125	0,46
300	3,5A	RP35A	62	88	10,5	1" GAS	20	M10x25A	144	0,70
300	3,5B	RP35B	62	88	12,5	1" GAS	20	M12x25	144	0,68
300	4	RP4	72,5	98	12,5	1"1/4 GAS	22	M12x30	4187	0,91

#### DESIGNAZIONE PER ORDINE DESIGNATION FOR ORDER

Solo raccordo  
Only connector

Raccordo con viti metriche, grower e o-ring  
Connectors with metric screws, grower type washers and o-ring

#### Materiale / Material

ST52.3

RP...

RP...M

#### NOTE / NOTES

Rivestimento superficiale: zincatura bianca.  
Superficial coating: white zinking.



## RACCORDI POMPA TIPO RPI

### STRAIGHT CONNECTORS RPI TYPE

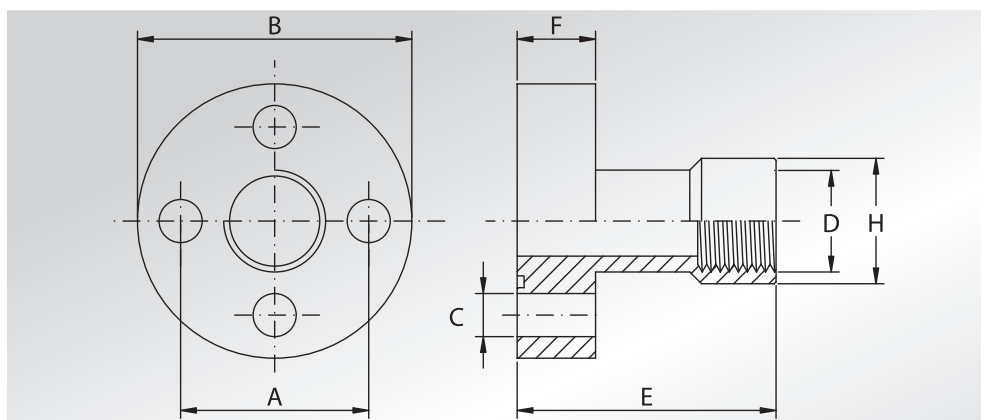

Pressione max di esercizio raccomandata Kg/cm <sup>2</sup>	Gruppo pompa	Tipo	Dimensioni							Viti Metriche	Or tipo	Peso Kg
Maximum recommended working pressure Kg/cm <sup>2</sup>	Pump group	Type	Dimensions							Metric screws	Or type	Weight Kg
			A	B	C	D	E	F	H			
300	1	RPI1	30	45	6,5	3/8" GAS	55	10	22	M6x20	2075	0,14
300	2	RPI2	40	58	8,5	1/2" GAS	60	12	26,5	M8x25	2100	0,28
300	3A	RPI3A	51	76	10,5	3/4" GAS	72	16	33,5	M10x30A	3125	0,62
300	3B	RPI3B	56	76	10,5	3/4" GAS	72	16	33,5	M10x30A	3125	0,62

#### DESIGNAZIONE PER ORDINE DESIGNATION FOR ORDER

Solo raccordo  
Only connector

Raccordo con viti metriche, grower e o-ring  
Connectors with metric screws, grower type washers and o-ring

#### Materiale / Material

ST52.3

RPI...

RPI...M

#### NOTE / NOTES

Rivestimento superficiale: zincatura bianca.  
Superficial coating: white zinking.



**RACCORDI  
POMPA  
TIPO RPE**



**STRAIGHT  
CONNECTORS  
RPE TYPE**

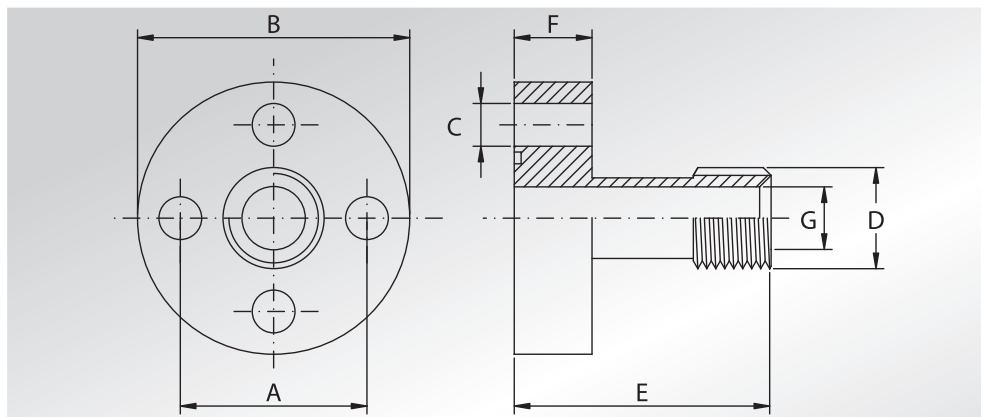

Pressione max di esercizio raccomandata Kg/cm <sup>2</sup>	Gruppo pompa	Tipo	Dimensioni							Viti Metriche	Or tipo	Peso Kg
Maximum recommended working pressure Kg/cm <sup>2</sup>	Pump group	Type	Dimensions							Metric screws	Or type	Weight Kg
			A	B	C	D	E	F	G			
300	1	RPE1	30	45	6,5	1/2" GAS	55	10	14	M6x20	2075	0,14
300	2	RPE2	40	58	8,5	3/4" GAS	60	12	19	M8x25	2100	0,26
300	3A	RPE3A	51	76	10,5	1" GAS	72	16	24	M10x30A	3125	0,58
300	3B	RPE3B	56	76	10,5	1" GAS	72	16	24	M10x30A	3125	0,58

**DESIGNAZIONE PER ORDINE  
DESIGNATION FOR ORDER**

**Materiale / Material**

**ST52.3**

Solo raccordo  
Only connector

**RPE...**

Raccordo con viti metriche, grower e o-ring  
Connectors with metric screws, grower type washers and o-ring

**RPE...M**

**NOTE / NOTES**

Rivestimento superficiale: zincatura bianca.  
Superficial coating: white zinking.

**RACCORDI  
POMPA  
TIPO RPS**



**STRAIGHT  
CONNECTORS  
RPS TYPE**

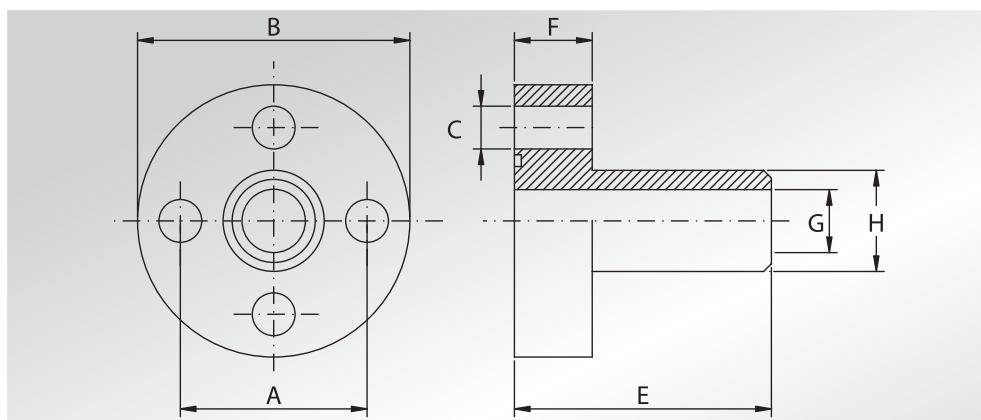

Pressione max di esercizio raccomandata Kg/cm <sup>2</sup>	Gruppo pompa	Tipo	Dimensioni							Viti Metriche	Or tipo	Peso Kg
Maximum recommended working pressure Kg/cm <sup>2</sup>	Pump group	Type	Dimensions							Metric screws	Or type	Weight Kg
			A	B	C	E	F	G	H			
300	1	RPS1	30	45	6,5	55	10	14	19	M6x20	2075	0,14
300	2	RPS2	40	58	8,5	60	12	19	25,4	M8x25	2100	0,28
300	3A	RPS3A	51	76	10,5	72	16	24,5	32	M10x30A	3125	0,60
300	3B	RPS3B	56	76	10,5	72	16	24,5	32	M10x30A	3125	0,60

**DESIGNAZIONE PER ORDINE  
DESIGNATION FOR ORDER**

**Materiale / Material**

**ST52.3**

Solo raccordo  
Only connector

**RPS...**

Raccordo con viti metriche, grower e o-ring  
Connectors with metric screws, grower type washers and o-ring

**RPS...M**

**NOTE / NOTES**

Rivestimento superficiale: zincatura bianca.  
Superficial coating: white zinking.



# RACCORDI DIRITTI FILETTATI METRICI DIN 3901-3902

## DIN 3901-3902 METRIC THREADED STRAIGHT CONNECTORS

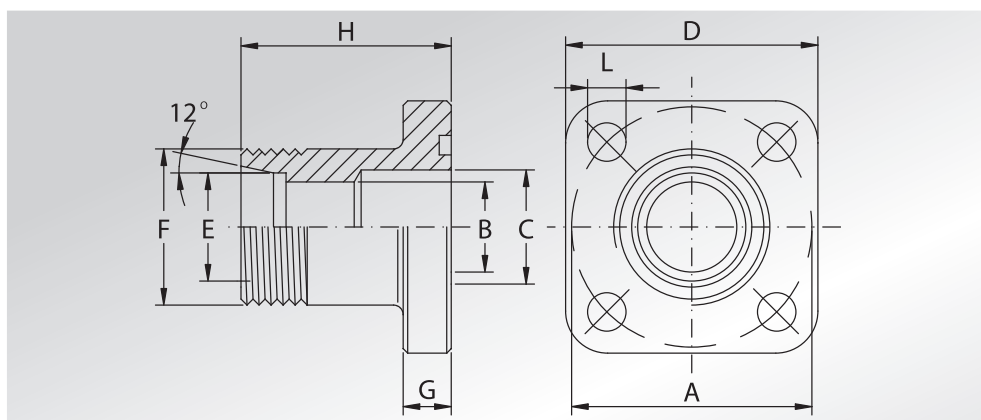

Pressione max di esercizio raccomandata Kg/cm <sup>2</sup>	Interasse	Tipo	Dimensioni									Viti Metriche	Or tipo	Peso Kg
Maximum recommended working pressure Kg/cm <sup>2</sup>	Distance between the holes	Type	Dimensions									Metric screws	Or type	Weight Kg
			A	B	C	D	E	F	G	H	L			
315	35	GF35LKL10315	35	8	12	39	10	M16x1,5	8	30	6,4	M6x20	3075	0,09
315	35	GF35LKL12315	35	10	12	39	12	M18x1.5	8	30	6,4	M6x20	3075	0,09
250	35	GF35LKL15250	35	12	12	39	15	M22x1.5	8	30	6,4	M6x20	3075	0,10
250	35	GF35LKS16250	35	12	12	39	16	M24x1.5	8	30	6,4	M6x20	3075	0,11
250	35	GF35LKL18250	35	12	12	39	18	M26x1.5	8	30	6,4	M6x20	3075	0,13
100	40	GF40LKL15100	40	12	19	42	15	M22x1.5	8	35	6,4	M6x20	132	0,12
100	40	GF40LKL18100	40	15	19	42	18	M26x1.5	8	35	6,4	M6x20	132	0,12
100	40	GF40LKL22100	40	19	19	42	22	M30x2	8	35	6,4	M6x20	132	0,13
100	40	GF40LKL28100	40	20	20	42	28	M36x2	8	42	6,4	M6x20	132	0,16
250	55	GF55LKS20250 (*)	55	16	16	55	20	M30x2	12	40	8,4	M8x30	4118	0,30
100	55	GF55LKL35100 (*)	55	24	24	60	35	M45x2	12	50	8,4	M8x30	4118	0,40

### DESIGNAZIONE PER ORDINE DESIGNATION FOR ORDER

Solo raccordo  
Only connector

### Materiale / Material

ST52.3

GF...LK...

### NOTE / NOTES

Rivestimento superficiale: zincatura.  
Superficial coating: zinking.

(\*) ESECUZIONE SOLO SU RICHIESTA  
MINIMO 50 PEZZI RICAVATI DA BARRA

(\*) EXECUTION ONLY ON REQUEST FOR  
MINIMUM 50 PIECES OBTAINED FROM BAR



**PUMP ELBOWS  
WITH THREE  
FIXING HOLES**

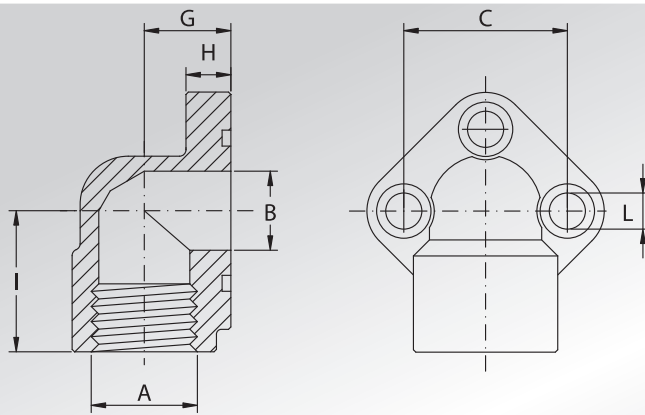

Pressione max di esercizio raccomandata Kg/cm <sup>2</sup>	Gruppo pompa	Tipo	Dimensioni							Viti Metriche	Or tipo	Peso Kg
Maximum recommended working pressure Kg/cm <sup>2</sup>	Pump group	Type	Dimensions							Metric screws	Or type	Weight Kg
			A	B	C	G	H	I	L			
300	0,5	RP9005038	3/8" GAS	11	26	17	8	24	5,3	M5x20	2056	0,17
300	0,5	RP9005012	1/2" GAS	11	26	17	8	24	5,3	M5x20	2056	0,15
300	1	RP901038	3/8" GAS	12	30	17	8	24	6,4	M6x20	121	0,17
300	1	RP901012	1/2" GAS	12	30	17	8	26	6,4	M6x20	121	0,15
300	2	RP902012	1/2" GAS	19	40	21	10	30	8,5	M8x25A	132	0,34
300	2	RP902034	3/4" GAS	19	40	21	10	30	8,5	M8x25A	132	0,30
300	3	RP903A034	3/4" GAS	26	51	26	13	45	10,5	M10x30A	3125	0,61
300	3	RP903A100	1" GAS	26	51	26	13	45	10,5	M10x30A	3125	0,54
300	3	RP903B034	3/4" GAS	26	56	26	13	45	10,5	M10x30A	3125	0,61
300	3	RP903B100	1" GAS	26	56	26	13	45	10,5	M10x30A	3125	0,54

**DESIGNAZIONE PER ORDINE  
DESIGNATION FOR ORDER**

**Materiale / Material**

**NOTE / NOTES**

Solo raccordo  
Only elbow

**RP90...**

Rivestimento superficiale: zincatura.  
Superficial coating: zinking.

Raccordo con viti metriche, grower e o-ring  
Elbow with metric screws, grower type washers and o-ring

**RP90...M**



**RACCORDI  
A 4 FORI A 90°  
FILETTATI METRICI  
DIN 3901 - 3902**

**DIN 3901 - 3902  
METRIC THREADED  
90° CONNECTORS  
WITH 4 FIXING HOLES**

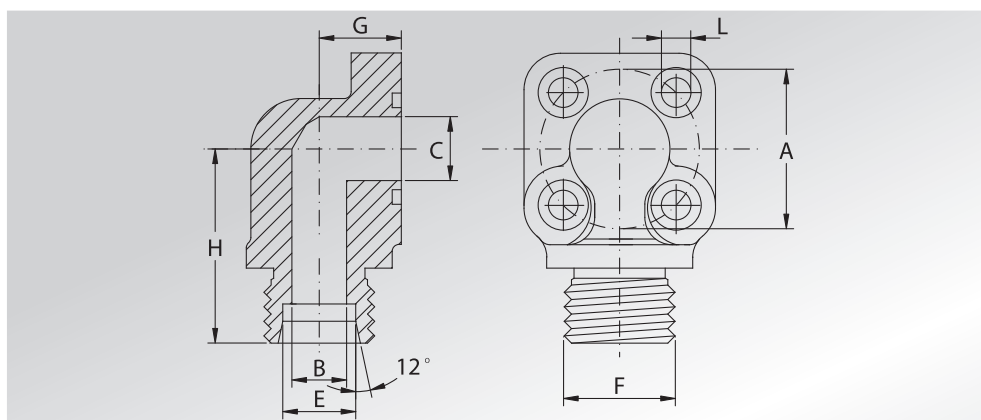

Pressione max di esercizio raccomandata Kg/cm <sup>2</sup>	Interasse	Tipo	Dimensioni								Viti Metriche	Or tipo	Peso Kg
Maximum recommended working pressure Kg/cm <sup>2</sup>	Distance between the holes	Type	Dimensions								Metric screws	Or type	Weight Kg
			A	B	C	E	F	G	H	L			
300	35	GF3590M16	35	8	13	10	M16x1,5	18	41,5	6,4	N.2 M6x35 N.2 M6x20	3075	0,15
300	35	GF3590M18	35	10	13	12	M18x1.5	18	41,5	6,4	N.2 M6x35 N.2 M6x20	3075	0,18
250	35	GF3590M22	35	12	13	15	M22x1.5	18	41,5	6,4	N.2 M6x35 N.2 M6x20	3075	0,20
250	35	GF3590M24	35	12	13	16	M24x1.5	18	41,5	6,4	N.2 M6x35 N.2 M6x20	3075	0,22
250	35	GF3590M26	35	12	13	18	M26x1.5	18	41,5	6,4	N.2 M6x35 N.2 M6x20	3075	0,24
100	40	GF4090M22	40	12	19	15	M22x1.5	24	41,5	6,4	N.2 M6x45 N.2 M6x20	132	0,18
100	40	GF4090M26	40	15	19	18	M26x1.5	24	41,5	6,4	N.2 M6x45 N.2 M6x20	132	0,20
100	40	GF4090M30	40	17	19	22	M30x2	24	41,5	6,4	N.2 M6x45 N.2 M6x20	132	0,25

**DESIGNAZIONE PER ORDINE  
DESIGNATION FOR ORDER**

Solo raccordo  
Only elbow

Raccordo con viti metriche, grower e o-ring  
Elbow with metric screws, grower type washers and o-ring

**Materiale / Material**

**ST52.3**

**GF..90M...**

**GF..90M...M**

**NOTE / NOTES**

Rivestimento superficiale: zincatura.  
Superficial coating: zinking.

**RACCORDI  
A 4 FORI A 90°  
FILETTATI GAS**



**BSP THREADED 90°  
CONNECTORS  
WITH 4 FIXING  
HOLES**

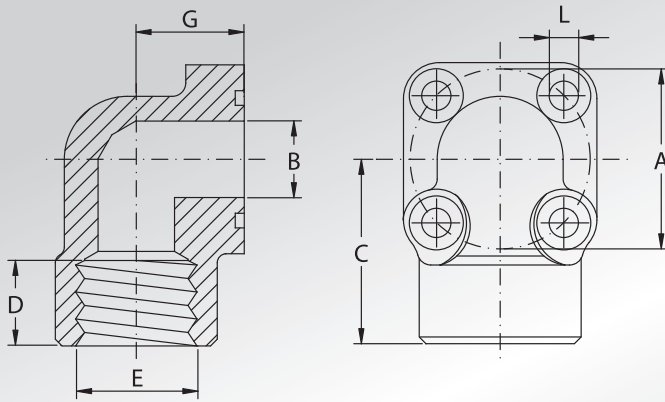

Pressione max di esercizio raccomandata Kg/cm <sup>2</sup>	Interasse	Tipo	Dimensioni							Viti Metriche	Or tipo	Peso Kg
Maximum recommended working pressure Kg/cm <sup>2</sup>	Distance between the holes	Type	Dimensions							Metric screws	Or type	Weight Kg
			A	B	C	D	E	G	L			
300	35	GF3590038	35	13	41,5	16	3/8" GAS	18	6,4	N.2 M6x35 N.2 M6x20	3075	0,3
300	35	GF3590012	35	13	41,5	19	1/2" GAS	18	6,4	N.2 M6x35 N.2 M6x20	3075	0,28
300	40	GF4090012	40	19	41,5	19	1/2" GAS	24	6,4	N.2 M6x45 N.2 M6x20	132	0,38
300	40	GF4090034	40	19	41,5	19	3/4" GAS	24	6,4	N.2 M6x45 N.2 M6x20	132	0,36

**DESIGNAZIONE PER ORDINE  
DESIGNATION FOR ORDER**

**Materiale / Material**

**NOTE / NOTES**

Solo raccordo  
Only elbow

**GF..90...**

Rivestimento superficiale: zincatura.  
Superficial coating: zinking.

Raccordo con viti metriche, grower e o-ring  
Elbow with metric screws, grower type washers and o-ring

**GF..90...M**



**NOTE**

**NOTES**

A large area of horizontal grey lines, intended for writing notes.

**TABELLE TECNICHE PER  
FLANGE CETOP**

**TECHNICAL TABLES FOR  
CETOP FLANGES**





## FLANGE CETOP

## CETOP FLANGES

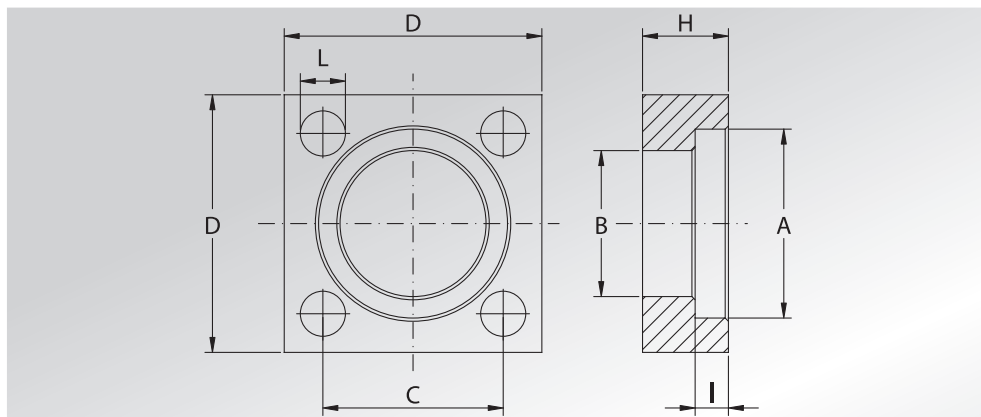

Pressione max di esercizio raccomandata Kg/cm <sup>2</sup>	Grandezza	Tipo	Dimensioni							Peso Kg
Maximum recommended working pressure Kg/cm <sup>2</sup>	Size	Type	Dimensions							Weight Kg
			A	B	C	D	H	I	L	

### SERIE 3000

250	3/8"	CET38ST250	25,1	18,5	24,7	40	14	6,3	6,5	0,13
250	1/2"	CET12ST250	31,0	24,3	29,7	45	15	6,3	8,5	0,15
250	3/4"	CET34ST250	38,9	32,1	35,3	50	16	6,3	8,5	0,17
250	1"	CET1ST250	45,3	38,5	43,8	65	18	7,6	11	0,36
250	1"1/4	CET114ST250	51,6	43,70	51,6	75	22	7,6	13	0,59
250	1"1/2	CET112ST250	61,1	50,80	60,0	85	25	7,6	15	0,80
250	2"	CET2ST250	72,2	62,70	69,4	100	30	9,1	17	1,30
250	2"1/2	CET212ST250	88,0	76,60	83,4	120	35	9,1	21	2,20
250	3"	CET3ST250	102,3	90,80	102,5	140	40	9,1	21	3,50
250	3"1/2	CET312ST250	120,0	102,50	102,5	140	52	17,5	21	3,60
250	4"	CET4ST250	132,0	114,50	113,2	160	60	21,0	25	5,70

### SERIE 6000

400	3/8"	CET38ST400	26,50	18,5	24,7	40	16	7,4	6,5	0,14
400	1/2"	CET12ST400	32,50	24,6	29,7	45	17	7,4	8,5	0,16
400	3/4"	CET34ST400	40,00	32,5	35,3	50	20	8,4	8,5	0,20
400	1"	CET1ST400	48,40	38,5	43,8	65	24	9,1	11	0,45
400	1"1/4	CET114ST400	54,80	44,50	51,6	75	28	9,9	13	0,71
400	1"1/2	CET112ST400	64,30	51,60	60,0	85	32	12,2	15	1,00
400	2"	CET2ST400	80,20	67,60	69,4	100	40	12,2	17	1,59
400	2"1/2	CET212ST400	95,00	80,50	83,4	120	45	16,1	21	2,55
400	3"	CET3ST400	105,00	90,50	102,5	140	52	16,1	21	4,50
400	3"1/2	CET312ST400	120,00	102,50	102,5	140	52	17,5	21	3,60
400	4"	CET4ST400	132,00	114,50	113,2	160	60	21,0	25	5,70

DESIGNAZIONE PER ORDINE  
DESIGNATION FOR ORDER

Solo flangia  
Only flange

Materiale / Material  
A105 o similare (or similar)

CET...ST...

NOTE / NOTES



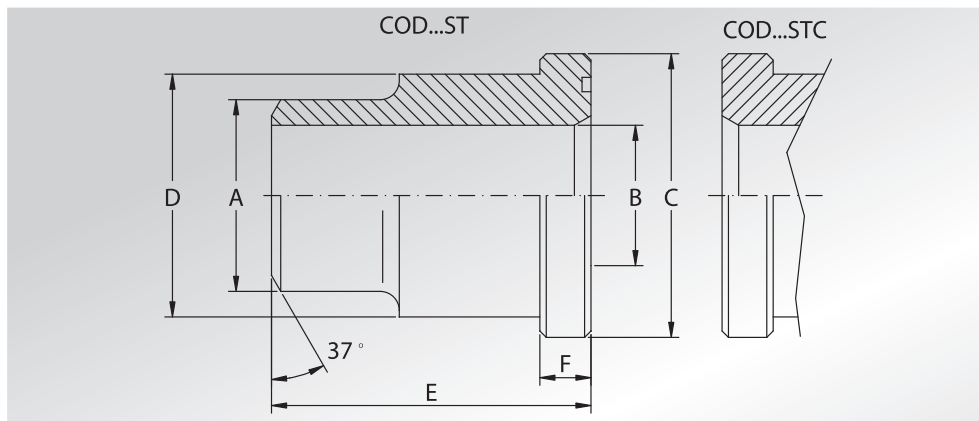

**CODOLI  
A SILDARE DI  
TESTA CETOP**



**WELD ON CETOP  
ADAPTERS**

Pressione max di esercizio raccomandata Kg/cm <sup>2</sup>	Grandezza	Tipo	Dimensioni						Or tipo	Peso Kg
Maximum recommended working pressure Kg/cm <sup>2</sup>	Size	Type	Dimensions						Or type	Weight Kg
			A	B	C	D	E	F		

### SERIE 3000

250	3/8"	COD38ST250	18	12,5	24,5	18	30	7,3	3068	0,05
250	1/2"	COD12ST250	22	15	30,2	24	30	7,3	4075	0,07
250	3/4"	COD34ST250	28	20	38,1	31,5	35	7,3	4100	0,13
250	1"	COD1ST250	35	25	44,4	38	40	8,6	4131	0,21
250	1"1/4	COD114ST250	43	32	50,8	43	45	8,6	4150	0,27
250	1"1/2	COD112ST250	50	38	60,3	50	50	8,6	4187	0,39
250	2"	COD2ST250	62	47	71,4	62	60	10,6	4225	0,69
250	2"1/2	COD212ST250	76	58	87,2	76	70	10,6	4275	1,16
250	3"	COD3ST250	90	70	101,6	90	80	10,6	4337	1,73
250	3"1/2	COD312ST250	102	80	119,0	102	90	19,0	4337	2,67
250	4"	COD4ST250	114	90	131,0	114	105	22,5	4387	3,75
250	4"	COD4ST250(OR6387)	114	90	131,0	114	105	22,5	6387	3,75

### SERIE 6000

400	3/8"	COD38ST400	18	11	26,0	18	35	8,4	3068	0,07
400	1/2"	COD12ST400	22	14	31,8	24	40	8,4	4075	0,11
400	3/4"	COD34ST400	28	18	39,5	32	45	9,4	4100	0,20
400	1"	COD1ST400	35	22	47,6	38	50	10,1	4131	0,32
400	1"1/4	COD114ST400	44	29	54,0	44	55	10,9	4150	0,44
400	1"1/2	COD112ST400	51	35	63,5	51	60	13,2	4187	0,63
400	2"	COD2ST400	61	43	79,4	67	70	13,7	4225	1,21
400	2"1/2	COD212ST400	80	53	94,2	80	80	17,6	4275	2,04
400	2"1/2	COD212ST400(OR6275)	80	53	94,2	80	80	17,6	6275	2,04
400	3"	COD3ST400	90	58	104,0	90	90	17,6	4275	2,93
400	3"	COD3ST400(OR6300)	90	58	104,0	90	90	17,6	6300	2,93
400	3"1/2	COD312ST400	102	63	119,0	102	90	19	4275	4,00
400	4"	COD4ST400	114	74	131,0	114	105	22,5	4337	5,45
400	4"	COD4ST400(OR6350)	114	74	131,0	114	105	22,5	6350	5,45

**DESIGNAZIONE PER ORDINE  
DESIGNATION FOR ORDER**

**Materiale / Material**

**NOTE / NOTES**

**A105 o similare (or similar)**

**AISI 316L**

Codolo con sede o-ring  
Adapter with o-ring groove

**COD...ST**

**CODX...ST**

Codolo senza sede o-ring  
Adapter without o-ring groove

**COD...STC**

**CODX...STC**



**CODOLI CIECHI  
CETOP**

**CETOP  
BLIND ADAPTERS**

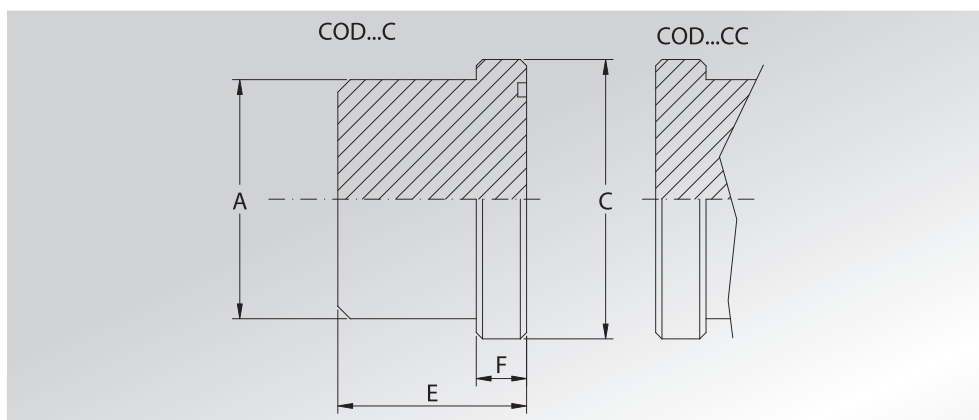

Pressione max di esercizio raccomandata Kg/cm <sup>2</sup>	Grandezza	Tipo	Dimensioni				Or tipo	Peso Kg
Maximum recommended working pressure Kg/cm <sup>2</sup>	Size	Type	Dimensions				Or type	Weight Kg
			A	C	E	F		

**SERIE 3000**

250	3/8"	COD38C250	18	24,5	15	7,3	3068	0,04
250	1/2"	COD12C250	24	30,2	16	7,3	4075	0,07
250	3/4"	COD34C250	31,5	38,1	17	7,3	4100	0,13
250	1"	COD1C250	38	44,4	19	8,6	4131	0,19
250	1"1/4	COD114C250	43	50,8	23	8,6	4150	0,30
250	1"1/2	COD112C250	50	60,3	26	8,6	4187	0,46
250	2"	COD2C250	62	71,4	31	10,6	4225	0,82
250	2"1/2	COD212C250	76	87,2	37	10,6	4275	1,44
250	3"	COD3C250	90	101,6	42	10,6	4337	2,25
250	3"1/2	COD312C250	102	119,0	54	19,0	4337	3,90
250	4"	COD4C250	114	131,0	62	22,5	4387	5,54
250	4"	COD4C250(OR6387)	114	131,0	62	22,5	6387	5,54

**SERIE 6000**

400	3/8"	COD38C400	18	26,0	17	8,4	3068	0,05
400	1/2"	COD12C400	24	31,8	19	8,4	4075	0,09
400	3/4"	COD34C400	32	39,5	21	9,4	4100	0,17
400	1"	COD1C400	38	47,6	25	10,1	4131	0,27
400	1"1/4	COD114C400	44	54,0	31	10,9	4150	0,44
400	1"1/2	COD112C400	51	63,5	33	13,2	4187	0,65
400	2"	COD2C400	67	79,4	42	13,7	4225	1,32
400	2"1/2	COD212C400	80	94,2	47	17,6	4275	2,13
400	2"1/2	COD212C400(OR6275)	80	94,2	47	17,6	6275	2,13
400	3"	COD3C400	90	104,0	54	17,6	4275	3,00
400	3"	COD3C400(OR6300)	90	104,0	54	17,6	6300	3,00
400	3"1/2	COD312C400	102	119,0	54	19	4275	3,90
400	4"	COD4C400	114	131,0	62	22,5	4337	5,54
400	4"	COD4C400(OR6350)	114	131,0	62	22,5	6350	5,54

DESIGNAZIONE PER ORDINE DESIGNATION FOR ORDER	Materiale / Material	
	A105 o similare (or similar)	AISI 316L
Codolo con sede o-ring Adapter with o-ring groove	<b>COD...C</b>	<b>CODX...C</b>
Codolo senza sede o-ring Adapter without o-ring groove	<b>COD...CC</b>	<b>CODX...CC</b>

**NOTE / NOTES**

**GRUPPO FLANGIA  
CETOP CON CODOLO  
A SALDARE  
DI TESTA E SET VITI  
METRICHE**



**GROUP OF CETOP  
FLANGE WITH WELD  
ON ADAPTER  
AND METRIC  
SCREWS SET**

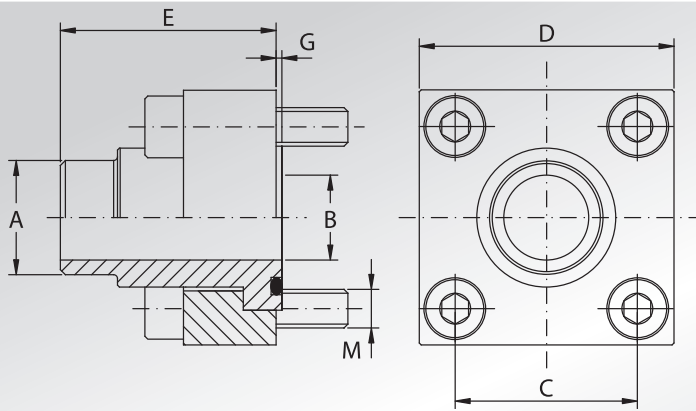

Pressione max di esercizio raccomandata Kg/cm <sup>2</sup>	Grandezza	Tipo	Dimensioni							Or tipo	Peso Kg
Maximum recommended working pressure Kg/cm <sup>2</sup>	Size	Type	Dimensions							Or type	Weight Kg
			A	B	C	D	E	G	M		

**SERIE 3000**

250	3/8"	GCET38ST250	18	12,5	24,7	40	30	1	M6x35	3068	0,20
250	1/2"	GCET12ST250	22	15	29,7	45	30	1	M8x30	4075	0,29
250	3/4"	GCET34ST250	28	20	35,3	50	35	1	M8x30	4100	0,37
250	1"	GCET1ST250	35	25	43,8	65	40	1	M10x35	4131	0,69
250	1"1/4	GCET114ST250	43	32	51,6	75	45	1	M12x40	4150	1,05
250	1"1/2	GCET112ST250	50	38	60,0	85	50	1	M14x45	4187	1,48
250	2"	GCET2ST250	62	47	69,4	100	60	1,5	M16x55	4225	2,44
250	2"1/2	GCET212ST250	76	58	83,4	120	70	1,5	M20x60	4275	4,18
250	3"	GCET3ST250	90	70	102,5	140	80	1,5	M20x70	4337	6,14
250	3"1/2	GCET312ST250	102	80	102,5	140	90	1,5	M20x90	4337	7,40
250	4"	GCET4ST250	114	90	113,2	160	105	1,5	M24x100	4387	11,30
250	4"	GCET4ST250(OR6387)	114	90	113,2	160	105	1,5	M24x100	6387	11,30

**SERIE 6000**

400	3/8"	GCET38ST400	18	11	24,7	40	35	1	M6x35	3068	0,24
400	1/2"	GCET12ST400	22	14	29,7	45	40	1	M8x30	4075	0,34
400	3/4"	GCET34ST400	28	18	35,3	50	45	1	M8x35	4100	0,48
400	1"	GCET1ST400	35	22	43,8	65	50	1	M10x40	4131	0,90
400	1"1/4	GCET114ST400	44	29	51,6	75	55	1	M12x45	4150	1,36
400	1"1/2	GCET112ST400	51	35	60,0	85	60	1	M14x55	4187	1,97
400	2"	GCET2ST400	61	43	69,4	100	70	1,5	M16x60	4225	3,32
400	2"1/2	GCET212ST400	80	53	83,4	120	80	1,5	M20x70	4275	5,50
400	2"1/2	GCET212ST400(OR6275)	80	53	83,4	120	80	1,5	M20x70	6275	5,50
400	3"	GCET3ST400	90	58	102,5	140	90	1,5	M20x90	4275	8,55
400	3"	GCET3ST400(OR6300)	90	58	102,5	140	90	1,5	M20x90	6300	8,55
400	3"1/2	GCET312ST400	102	63	102,5	140	90	1,5	M20x90	4275	8,71
400	4"	GCET4ST400	114	74	113,2	160	105	1,5	M24x100	4337	13,00
400	4"	GCET4ST400(OR6350)	114	74	113,2	160	105	1,5	M24x100	6350	13,00

**DESIGNAZIONE PER ORDINE  
DESIGNATION FOR ORDER**

1 Flangia cetop - 1 Codolo con sede o-ring - 4 Viti TCE - 4 Grower - 1 O-ring  
1 Cetop flange - 1 Adapter with o-ring groove - 4 TCE screws - 4 Growers - 1 O-ring

**Materiale / Material**

A105 o similare (or similar)

**GCET...ST...**

**NOTE / NOTES**



**GRUPPO  
FLANGIA CETOP  
CON CODOLO CIECO  
E SET VITI METRICHE**

**GROUP OF CETOP  
FLANGE WITH BLIND  
ADAPTER AND METRIC  
SCREWS SET**

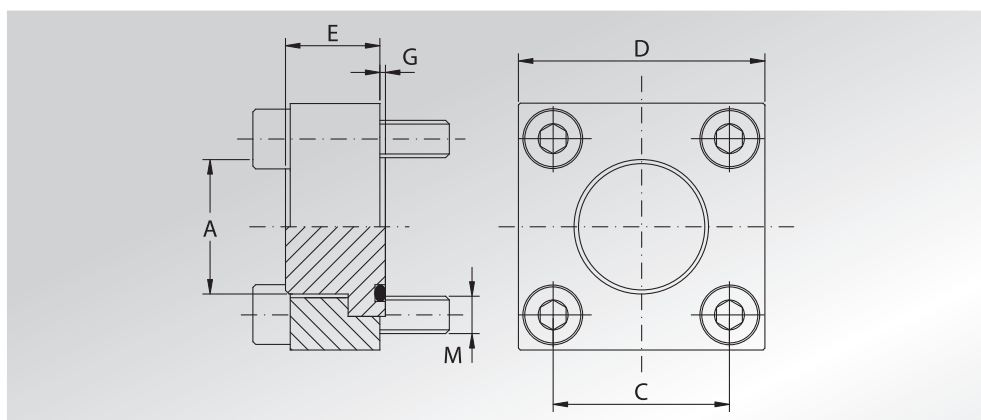

Pressione max di esercizio raccomandata Kg/cm <sup>2</sup>	Grandezza	Tipo	Dimensioni						Or tipo	Peso Kg
Maximum recommended working pressure Kg/cm <sup>2</sup>	Size	Type	Dimensions						Or type	Weight Kg
			A	C	D	E	G	M		

**SERIE 3000**

250	3/8"	GCET38C250	18	24,7	40	15	1	M6x35	3068	0,20
250	1/2"	GCET12C250	22	29,7	45	16	1	M8x30	4075	0,29
250	3/4"	GCET34C250	28	35,3	50	17	1	M8x30	4100	0,37
250	1"	GCET1C250	35	43,8	65	19	1	M10x35	4131	0,69
250	1"1/4	GCET114C250	43	51,6	75	23	1	M12x40	4150	1,05
250	1"1/2	GCET112C250	50	60,0	85	26	1	M14x45	4187	1,48
250	2"	GCET2C250	62	69,4	100	31	1,5	M16x55	4225	2,44
250	2"1/2	GCET212C250	76	83,4	120	37	1,5	M20x60	4275	4,18
250	3"	GCET3C250	90	102,5	140	42	1,5	M20x70	4337	6,14
250	3"1/2	GCET312C250	102	102,5	140	54	1,5	M20x90	4337	7,40
250	4"	GCET4C250	114	113,2	160	62	1,5	M24x100	4387	11,30
250	4"	GCET4C250(OR6387)	114	113,2	160	62	1,5	M24x100	6387	11,30

**SERIE 6000**

400	3/8"	GCET38C400	18	24,7	40	17	1	M6x35	3068	0,24
400	1/2"	GCET12C400	22	29,7	45	19	1	M8x30	4075	0,34
400	3/4"	GCET34C400	28	35,3	50	21	1	M8x35	4100	0,48
400	1"	GCET1C400	35	43,8	65	25	1	M10x40	4131	0,90
400	1"1/4	GCET114C400	44	51,6	75	31	1	M12x45	4150	1,36
400	1"1/2	GCET112C400	51	60,0	85	33	1	M14x55	4187	1,97
400	2"	GCET2C400	61	69,4	100	42	1,5	M16x60	4225	3,32
400	2"1/2	GCET212C400	80	83,4	120	47	1,5	M20x70	4275	5,50
400	2"1/2	GCET212C400(OR6275)	80	83,4	120	47	1,5	M20x70	6275	5,50
400	3"	GCET3C400	90	102,5	140	54	1,5	M20x90	4275	8,55
400	3"	GCET3C400(OR6300)	90	102,5	140	54	1,5	M20x90	6300	8,55
400	3"1/2	GCET312C400	102	102,5	140	54	1,5	M20x90	4275	8,71
400	4"	GCET4C400	114	113,2	160	62	1,5	M24x100	4337	13,00
400	4"	GCET4C400(OR6350)	114	113,2	160	62	1,5	M24x100	6350	13,00

**DESIGNAZIONE PER ORDINE  
DESIGNATION FOR ORDER**

1 Flangia cetop - 1 Codolo cieco con sede o-ring - 4 Viti TCE - 4 Grower - 1 O-ring  
1 Cetop flange - 1 Blind adapter with o-ring groove - 4 TCE screws - 4 Growers - 1 O-ring

**Materiale / Material**

A105 o similare (or similar)

**GCET...C...**

**NOTE / NOTES**

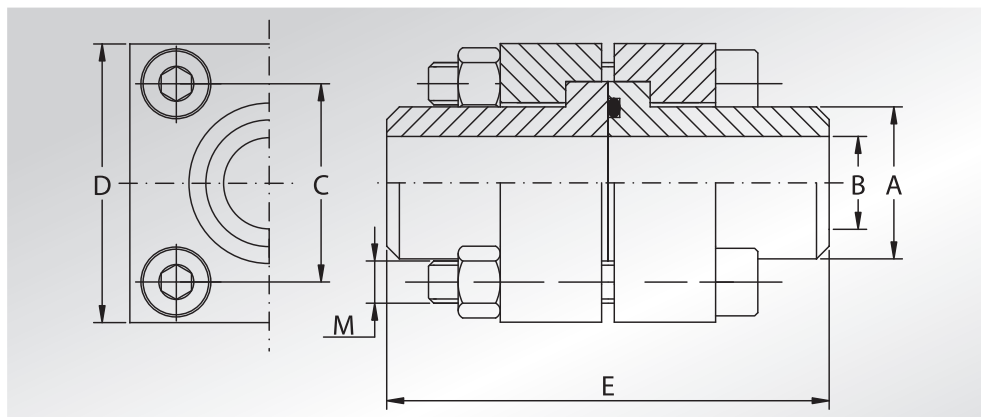

**DOBPIE FLANGE  
CETOP CON CODOLO  
E CONTROCODOLO  
A SALDARE DI TESTA  
E SET VITI METRICHE**



**CETOP DOUBLE  
FLANGES WITH WELD  
ON ADAPTER WITH  
AND WITHOUT O-RING  
SEAT AND METRIC  
SCREWS SET**

Pressione max di esercizio raccomandata Kg/cm <sup>2</sup>	Grandezza	Tipo	Dimensioni						Or tipo	Peso Kg
Maximum recommended working pressure Kg/cm <sup>2</sup>	Size	Type	Dimensions						Or type	Weight Kg
			A	B	C	D	E	M		

### SERIE 3000

250	3/8"	DCET38ST250	18	12,5	24,7	40	60	M6x45	3068	0,42
250	1/2"	DCET12ST250	22	15	29,7	45	60	M8x45	4075	0,52
250	3/4"	DCET34ST250	28	20	35,3	50	70	M8x45	4100	0,68
250	1"	DCET1ST250	35	25	43,8	65	80	M10x50	4131	1,30
250	1"1/4	DCET114ST250	43	32	51,6	75	90	M12x60	4150	1,98
250	1"1/2	DCET112ST250	50	38	60,0	85	100	M14x70	4187	2,78
250	2"	DCET2ST250	62	47	69,4	100	120	M16x90	4225	4,67
250	2"1/2	DCET212ST250	76	58	83,4	120	140	M20x100	4275	7,96
250	3"	DCET3ST250	90	70	102,5	140	160	M20x110	4337	11,80
250	3"1/2	DCET312ST250	102	80	102,5	140	180	M20x130	4337	14,10
250	4"	DCET4ST250	114	90	113,2	160	210	M24x160	4387	21,60
250	4"	DCET4ST250(OR6387)	114	90	113,2	160	210	M24x160	6387	21,60

### SERIE 6000

400	3/8"	DCET38ST400	18	11	24,7	40	70	M6x45	3068	0,47
400	1/2"	DCET12ST400	22	14	29,7	45	80	M8x50	4075	0,63
400	3/4"	DCET34ST400	28	18	35,3	50	90	M8x60	4100	0,90
400	1"	DCET1ST400	35	22	43,8	65	100	M10x70	4131	1,73
400	1"1/4	DCET114ST400	44	29	51,6	75	110	M12x80	4150	2,62
400	1"1/2	DCET112ST400	51	35	60,0	85	120	M14x90	4187	3,76
400	2"	DCET2ST400	61	43	69,4	100	140	M16x100	4225	6,40
400	2"1/2	DCET212ST400	80	53	83,4	120	160	M20x110	4275	10,50
400	2"1/2	DCET212ST400(OR6275)	80	53	83,4	120	160	M20x110	6275	10,50
400	3"	DCET3ST400	90	58	102,5	140	180	M20x130	4275	16,40
400	3"	DCET3ST400(OR6300)	90	58	102,5	140	180	M20x130	6300	16,40
400	3"1/2	DCET312ST400	102	63	102,5	140	180	M20x130	4275	16,70
400	4"	DCET4ST400	114	74	113,2	160	210	M24x160	4337	25,00
400	4"	DCET4ST400(OR6350)	114	74	113,2	160	210	M24x160	6350	25,00

#### DESIGNAZIONE PER ORDINE DESIGNATION FOR ORDER

2 Flange cetop - 1 Codolo con sede o-ring - 1 Codolo senza sede o-ring  
4 Viti TCE - 8 Grower - 4 Dadi - 1 O-ring

2 Cetop flanges - 1 Adapter with o-ring groove - 1 Adapter without o-ring groove  
4 TCE screws - 8 Growers - 4 Nuts - 1 O-ring

#### Materiale / Material

A105 o similare (or similar)

#### NOTE / NOTES

**DCET...ST...**



**DOPPIE FLANGE CETOP  
CON CODOLO CIECO  
E CONTROCODOLO  
A SALDARE DI TESTA  
E SET VITI METRICHE**

**CETOP DOUBLE FLANGES  
WITH BLIND ADAPTER  
AND WELD ON ADAPTER  
WITHOUT O-RING SEAT AND  
METRIC SCREWS SET**

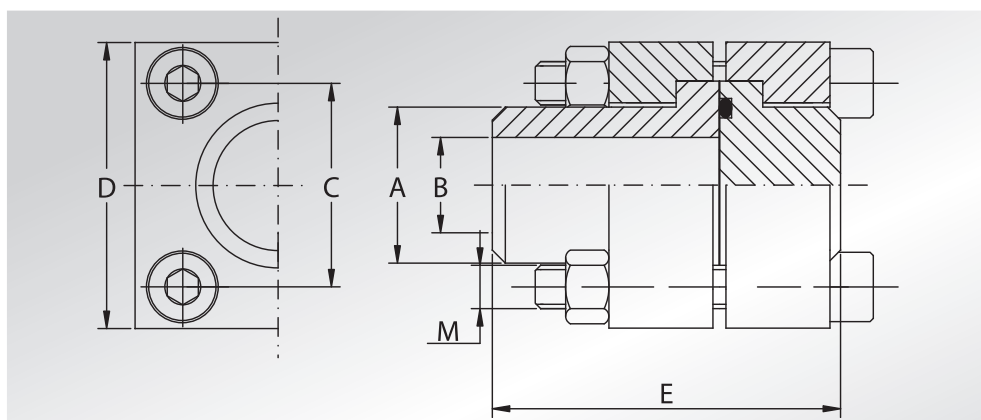

Pressione max di esercizio raccomandata Kg/cm <sup>2</sup>	Grandezza	Tipo	Dimensioni						Or tipo	Peso Kg
Maximum recommended working pressure Kg/cm <sup>2</sup>	Size	Type	Dimensions						Or type	Weight Kg
			A	B	C	D	E	M		

**SERIE 3000**

250	3/8"	DCET38C250	18	12,5	24,7	40	45	M6x45	3068	0,42
250	1/2"	DCET12C250	22	15	29,7	45	46	M8x45	4075	0,52
250	3/4"	DCET34C250	28	20	35,3	50	52	M8x45	4100	0,68
250	1"	DCET1C250	35	25	43,8	65	59	M10x50	4131	1,30
250	1"1/4	DCET114C250	43	32	51,6	75	68	M12x60	4150	1,98
250	1"1/2	DCET112C250	50	38	60,0	85	76	M14x70	4187	2,78
250	2"	DCET2C250	62	47	69,4	100	91	M16x90	4225	4,67
250	2"1/2	DCET212C250	76	58	83,4	120	107	M20x100	4275	7,96
250	3"	DCET3C250	90	70	102,5	140	122	M20x110	4337	11,80
250	3"1/2	DCET312C250	102	80	102,5	140	144	M20x130	4337	14,10
250	4"	DCET4C250	114	90	113,2	160	167	M24x160	4387	21,60
250	4"	DCET4C250(OR6387)	114	90	113,2	160	167	M24x160	6387	21,60

**SERIE 6000**

400	3/8"	DCET38C400	18	11	24,7	40	52	M6x45	3068	0,47
400	1/2"	DCET12C400	22	14	29,7	45	59	M8x50	4075	0,63
400	3/4"	DCET34C400	28	18	35,3	50	66	M8x60	4100	0,90
400	1"	DCET1C400	35	22	43,8	65	75	M10x70	4131	1,73
400	1"1/4	DCET114C400	44	29	51,6	75	86	M12x80	4150	2,62
400	1"1/2	DCET112C400	51	35	60,0	85	93	M14x90	4187	3,76
400	2"	DCET2C400	61	43	69,4	100	112	M16x100	4225	6,40
400	2"1/2	DCET212C400	80	53	83,4	120	127	M20x110	4275	10,50
400	2"1/2	DCET212C400(OR6275)	80	53	83,4	120	127	M20x110	6275	10,50
400	3"	DCET3C400	90	58	102,5	140	144	M20x130	4275	16,40
400	3"	DCET3C400(OR6300)	90	58	102,5	140	144	M20x130	6300	16,40
400	3"1/2	DCET312C400	102	63	102,5	140	144	M20x130	4275	16,70
400	4"	DCET4C400	114	74	113,2	160	167	M24x160	4337	25,00
400	4"	DCET4C400(OR6350)	114	74	113,2	160	167	M24x160	6350	25,00

**DESIGNAZIONE PER ORDINE  
DESIGNATION FOR ORDER**

2 Flange cetop - 1 Codolo cieco con sede o-ring - 1 Codolo a saldare di testa senza sede o-ring  
4 Viti TCE - 8 Grower - 4 Dadi - 1 O-ring

2 Cetop flanges - 1 Blind adapter with o-ring groove - 1 Weld on adapter without o-ring groove  
4 TCE screws - 8 Growers - 4 Nuts - 1 O-ring

**Materiale / Material**

**A105 o similare (or similar)**

**DCET...C...**

**NOTE / NOTES**

# FLANGE CETOP A 90°



## 90° CETOP FLANGES

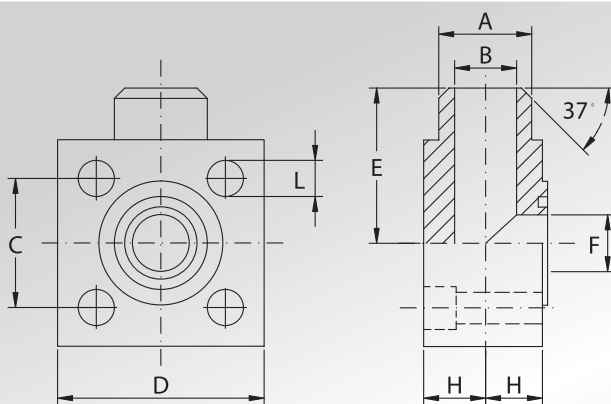

Pressione max di esercizio raccomandata Kg/cm <sup>2</sup>	Grandezza	Tipo	Dimensioni								Viti Metriche	Or tipo	Peso Kg
			Dimensions										
Maximum recommended working pressure Kg/cm <sup>2</sup>	Size	Type	A	B	C	D	E	F	H	L	Metric screws	Or type	Weight Kg
			<b>SERIE 3000</b>										
250	3/8"	CET38ST90250	18	12,5	24,7	40	32	12,5	12	6,8	M6x30	3068	0,24
250	1/2"	CET12ST90250	22	15	29,7	45	40	15	17	9	M8x40	4075	0,40
250	3/4"	CET34ST90250	28	20	35,3	50	42	20	19	9	M8x45	4100	0,57
250	1"	CET1ST90250	35	25	43,8	65	50	25	24	11	M10x55	4131	1,21
250	1"1/4	CET114ST90250	43	32	51,6	75	56	32	30	13	M12x70	4150	1,92
250	1"1/2	CET112ST90250	50	38	60,0	85	65	38	34	15	M14x80	4187	2,84
250	2"	CET2ST90250	62	47	69,4	100	75	47	42	17	M16x100	4225	4,75
250	2"1/2	CET212ST90250	76	58	83,4	120	85	58	53	21	M20x120	4275	8,67
250	3"	CET3ST90250	90	68	102,5	140	100	70	59	21	M20x140	4337	14,51

<b>SERIE 6000</b>													
400	3/8"	CET38ST90400	18	11	24,7	40	32	12,5	12	6,8	M6x30	3068	0,24
400	1/2"	CET12ST90400	22	14	29,7	45	40	15	17	9	M8x40	4075	0,40
400	3/4"	CET34ST90400	28	18	35,3	50	42	20	19	9	M8x45	4100	0,59
400	1"	CET1ST90400	35	22	43,8	65	50	25	24	11	M10x55	4131	1,25
400	1"1/4	CET114ST90400	44	29	51,6	75	56	32	30	13	M12x70	4150	2,00
400	1"1/2	CET112ST90400	51	35	60,0	85	65	38	34	15	M14x80	4187	2,86
400	2"	CET2ST90400	61	43	69,4	100	75	47	42	17	M16x100	4225	4,83
400	2"1/2	CET212ST90400(OR6275)	80	53	83,4	120	85	58	53	21	M20x120	6275	8,58
400	3"	CET3ST90400(OR6300)	90	58	102,5	140	100	58	59	21	M20x140	6300	14,51

**DESIGNAZIONE PER ORDINE**  
**DESIGNATION FOR ORDER**

**Materiale / Material**

**A105 o similare (or similar)**

**NOTE / NOTES**

Solo flangia  
Only flange

**CET...ST90...**



**NOTE**

**NOTES**

A series of horizontal grey lines providing a space for writing notes.



**TABELLE TECNICHE PER PRODOTTI  
IN ESECUZIONE SU RICHIESTA**

***TECHNICAL TABLES FOR PRODUCTS  
ON REQUEST***





# ADATTATORE SAE DI RIDUZIONE

## SAE REDUCER ADAPTER

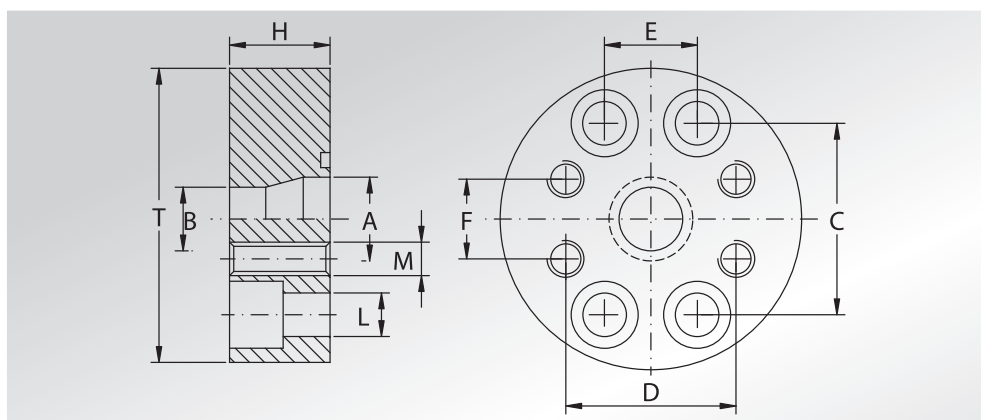

Pressione max di esercizio raccomandata Kg/cm <sup>2</sup>	Grandezza	Tipo	Dimensioni										Or tipo	Peso Kg
Maximum recommended working pressure Kg/cm <sup>2</sup>	Size	Type	Dimensions										Or type	Weight Kg
			A	B	C	D	E	F	H	L	M	T		

### SERIE 3000

200	1"	RIF102100	25	19	52,37	47,63	26,19	22,23	28	11	M10	80	4131	0,90
200	1"1/4	RIF104102	30	25	58,72	52,37	30,18	26,19	28	11,5	M10	90	4150	1,15
200	1"1/2	RIF106104	38	30	69,85	58,72	35,71	30,18	32	13,5	M10	105,0	4187	1,70
200	2"	RIF108106	50	38	77,77	69,85	42,88	35,71	32	13,5	M12	115,0	4225	2,00

### SERIE 6000

400	1"	RIF403402	25	19	57,15	50,80	27,76	23,80	30	13	M10	90,0	4131	1,20
400	1"1/4	RIF404403	30	25	66,68	57,15	31,75	27,76	35	15	M12	105	4150	2,00
400	1"1/2	RIF405404	38	30	79,38	66,68	36,50	31,75	50	17	M14	120	4187	3,70
400	2"	RIF406405	50	38	96,82	79,38	44,45	36,50	50	21	M16	145	4225	5,40

DESIGNAZIONE PER ORDINE  
DESIGNATION FOR ORDER

Adattatore  
Straight Adapter

Materiale / Material

ST52.3

AISI 316L

RIF...

RIFX...

NOTE / NOTES



**DOUBLE ADAPTERS**

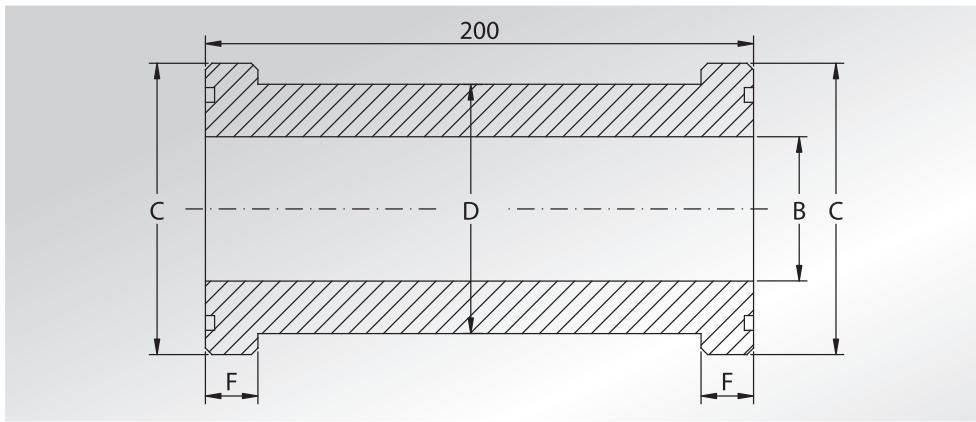

Pressione max di esercizio raccomandata Kg/cm <sup>2</sup>	Grandezza	Tipo	Dimensioni				Or tipo
Maximum recommended working pressure Kg/cm <sup>2</sup>	Size	Type	Dimensions				Or type
			B	C	D	F	

**SERIE 3000**

345	3/4"	SFS302D	19	38,1	32	6,73	4100
345	1"	SFS303D	25	44,4	38	8,00	4131
276	1"1/4	SFS304D	32	50,8	43	8,00	4150
207	1"1/2	SFS305D	38	60,3	50	8,00	4187
207	2"	SFS306D	50	71,4	62	9,53	4225

**SERIE 6000**

414	3/4"	SFS602D	19	41,3	32	8,76	4100
414	1"	SFS603D	25	47,6	38	9,53	4131
414	1"1/4	SFS604D	32	54,0	44	10,29	4150
414	1"1/2	SFS605D	38	63,5	51	12,57	4187
414	2"	SFS606D	50	79,4	67	12,57	4225

**DESIGNAZIONE PER ORDINE**  
**DESIGNATION FOR ORDER**

**Materiale / Material**

**NOTE / NOTES**

**A105 o similare (or similar)**

**AISI 316L**

Doppio codolo  
Double adapter

**SFS...D**

**SFX...D**



## FLANGE CETOP CIECHE

## BLIND CETOP FLANGES

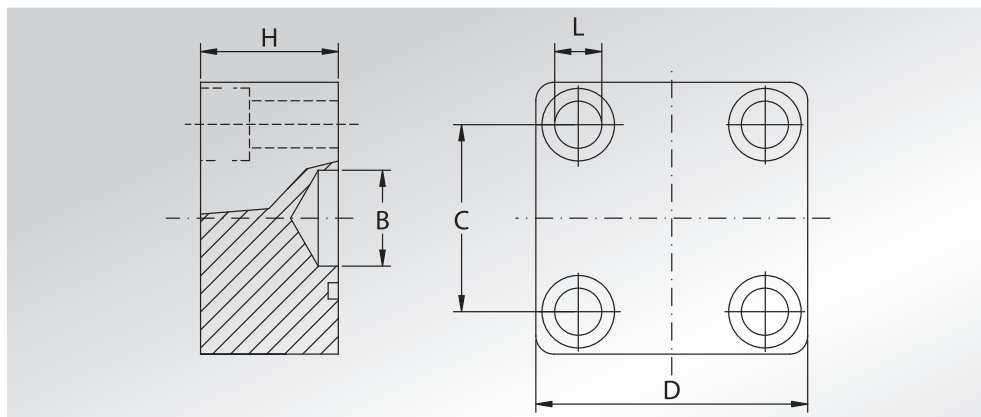

Pressione max di esercizio raccomandata Kg/cm <sup>2</sup>	Grandezza	Tipo	Dimensioni					Viti	Or tipo
Maximum recommended working pressure Kg/cm <sup>2</sup>	Size	Type	Dimensions					Screws	Or type
			B	C	D	H	L	Metric	

### SERIE 3000

250	1/2"	CET12C250	14	29,7	45	32	8,5	M8x45	4075
250	3/4"	CET34C250	19	35,3	50	32	8,5	M8x45	4100
250	1"	CET1C250	25	43,8	65	35	11	M10x50	4131
250	1"1/4	CET114C250	30	51,6	75	38	13	M12x55	4150
250	1"1/2	CET112C250	36	60,0	85	42	15	M14x65	4187
250	2"	CET2C250	45	69,4	100	44	17	M16x70	4225
250	2"1/2	CET212C250	58	83,4	120	55	21	M20x80	4275
250	3"	CET3C250	60	102,5	140	60	21	M20x90	4337
250	4"	CET4C250	70	113,2	160	60	25	M24x100	4387
250	4"	CET4C250 (OR6387)	70	113,2	160	60	25	M24x100	6787

### SERIE 6000

400	1/2"	CET12C400	14	29,7	45	32	8,5	M8x45	4075
400	3/4"	CET34C400	19	35,3	50	32	8,5	M8x45	4100
400	1"	CET1C400	25	43,8	65	35	11	M10x50	4131
400	1"1/4	CET114C400	30	51,6	75	38	13	M12x55	4150
400	1"1/2	CET112C400	36	60,0	85	42	15	M14x65	4187
400	2"	CET2C400	45	69,4	100	44	17	M16x70	4225
400	2"1/2	CET212C400	58	83,4	120	55	21	M20x80	4275
400	2"1/2	CET212C400 (OR6275)	58	83,4	120	55	21	M20x80	6275
400	3"	CET3C400	60	102,5	140	60	21	M20x90	4337
400	3"	CET3C400 (OR6300)	60	102,5	140	60	21	M20x90	6300
400	3"	CET4C400	70	113,2	160	60	25	M24x100	4337
400	3"	CET4C400 (OR6350)	70	113,2	160	60	25	M24x100	6350

DESIGNAZIONE PER ORDINE  
DESIGNATION FOR ORDER

Materiale / Material  
A105 o similare (or similar)

NOTE / NOTES

Solo flangia  
Only flange

CET...C

# BLOCCHI SAE A "T"



## SAE "T" BLOCKS

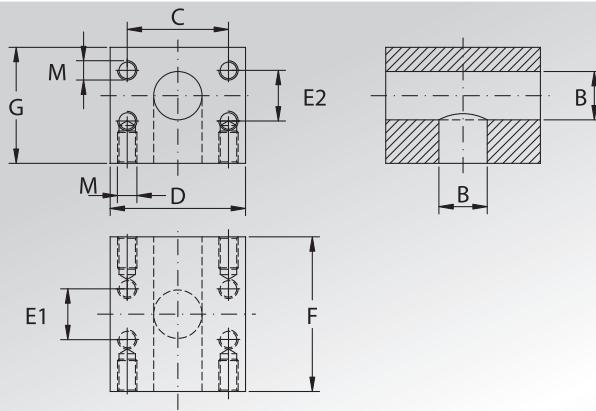

Pressione max di esercizio raccomandata Kg/cm <sup>2</sup>	Grandezza	Tipo	Dimensioni								Peso Kg
Maximum recommended working pressure Kg/cm <sup>2</sup>	Size	Type	Dimensions								Weight Kg
			B	C	D	E1	E2	F	G	M	

### SERIE 3000

345	3/4"	TBL302302	19	47,60	65	22,23	22,23	75	55	M10	1,80
345	1"	TBL303303	25	52,37	70	26,19	26,19	80	60	M10	2,30
276	1"1/4	TBL304304	32	58,79	80	30,18	30,18	90	70	M10	3,90
207	1"1/2	TBL305305	38	69,85	95	35,71	35,71	110	85	M12	6,30
207	2"	TBL306306	50	77,77	110	42,88	42,88	120	100	M12	8,30

### SERIE 6000

400	3/4"	TBL602602	19	50,80	72	23,80	23,80	70	55	M10	1,70
400	1"	TBL603603	23	57,15	82	27,76	27,76	80	64	M12	2,90
400	1"1/4	TBL604604	30	66,68	100	31,75	31,75	92	72	M14	3,80
400	1"1/2	TBL605605	38	79,38	110	36,50	36,50	98	100	M16	8,90
400	2"	TBL606606	50	96,82	133	44,45	44,45	140	105	M20	12,70

DESIGNAZIONE PER ORDINE  
DESIGNATION FOR ORDER

Blocco sae  
Sae block

Materiale / Material  
A105 o similare (or similar)

TBL.....

NOTE / NOTES



**NOTE**

**NOTES**

A series of horizontal grey lines providing a space for writing notes.

**TABELLE TECNICHE PER PRODOTTI  
ACCESSORI PER FLANGE SAE**

***TECHNICAL TABLES RELEVANT TO ACCESSORIES  
FOR SAE FLANGES***





**TABELLA RIASSUNTIVA  
CARATTERISTICHE  
TECNICHE  
FLANGE SAE**

**RESUMING TABLE  
WITH SAE  
FLANGES TECHNICAL  
CHARACTERISTICS**

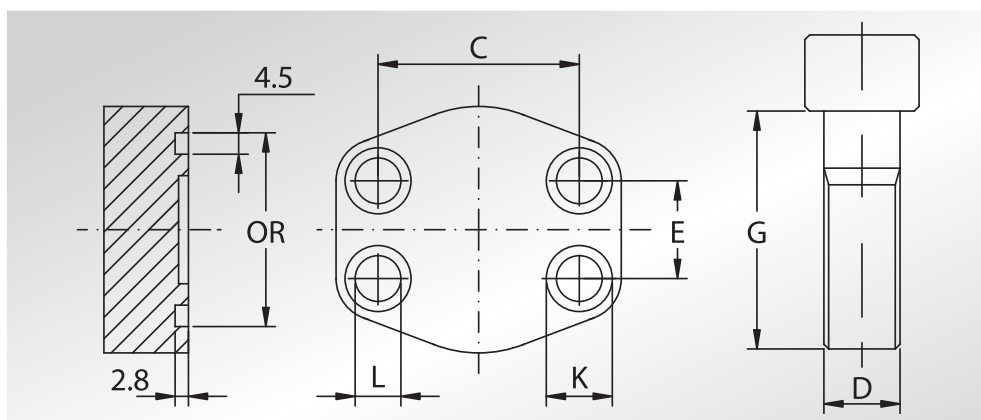

SAE	GRAND.	INTERASSE C	INTERASSE E	DIAM. FORI L	FILETT. METRICO DxG VITI METR.
SAE	SIZE	DISTANCE BETWEEN HOLES C	DISTANCE BETWEEN HOLES E	HOLES DIAM. L	METRIC THREAD DxG METRIC SCREWS
<b>SERIE 3000</b>					
1/2"	80	38,1	17,48	9	M8x30
3/4"	100	47,63	22,23	11	M10x35
1"	102	52,37	26,19	11	M10x35
1"1/4	104	58,72	30,18	11,5	M10x40
1"1/2	106	69,85	35,71	13,5	M12x45
2"	108	77,77	42,88	13,5	M12x45
2"1/2	110	88,90	50,80	13,5	M12x45
3"	112	106,38	61,93	17,5	M16x50
3"1/2	114	120,65	69,85	17,5	M16x50
4"	116	130,18	77,77	17,5	M16x50
<b>SERIE 6000</b>					
1/2"	401	40,49	18,24	9	M8x30
3/4"	402	50,80	23,80	11	M10x40
1"	403	57,15	27,76	13	M12x45
1"1/4	404	66,68	31,75	15	M14x45
1"1/2	405	79,38	36,50	17	M16x50
2"	406	96,82	44,45	21	M20x70
2"1/2	507	123,8	58,70	26	M24x100
3"	508	152,4	71,4	33	M30x100



GROWER METRIC.	FILETT. UNC DxG VITI UNC	GROWER UNC	LAMAT. K	O-RING	DIAM. EST. OR	TOLLER. O-RING
METRIC GROWER	UNC THREAD DxG UNC SCREWS	UNC GROWER	SPOT FACING K	O-RING	OUTSIDE OR DIAM.	O-RING TOLERANCES
8	5/16x1"1/4	8	-	4075	25,5	-0,15
10	3/8x1"1/2	10	17	4100	31,9	-0,15
10	3/8x1"1/2	10	17	4131	39,7	-0,15
10	7/16x1"3/4	7/16"	17,5	4150	44,6	-0,15
12	1/2x1"3/4	1/2"	20	4187	54	-0,25
12	1/2x1"3/4	1/2"	20	4225	63,5	-0,25
12	1/2x1"3/4	1/2"	20	4275	76,3	-0,25
16	5/8x2"	16	25	4337	92,1	-0,25
16	5/8x2"	16	25	4387	104,5	-0,3
16	5/8x2"	16	25	4437	117	+ / -0,2
8	5/16x1"1/4		-	4075	25,5	-0,15
10	3/8x1"1/2		17	4100	31,9	-0,15
14	7/16x1"3/4	7/16"	20	4131	39,7	-0,15
14	1/2x1"3/4	1/2"	22	4150	44,6	-0,15
16	5/8x2"	16	25	4187	54	-0,25
20	3/4x2"1/2	20	32	4225	63,5	-0,25
24	-	-	-	4275	76,3	-0,25
30	-	-	-	4337	92,1	-0,25



**RONDELLE GROWER  
DIN 7980**

**SPRINGLOCKWASHERS  
WITH SQUARE ENDS  
ACCORDING TO  
DIN 7980**

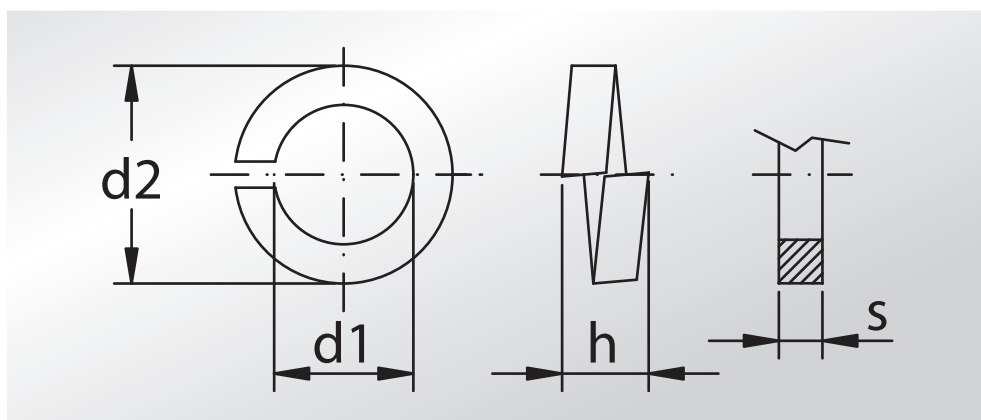

Per viti con diam.  For screws with diam.	d1	d2	s	h	
				Minimo Minimum	Massimo Maximum
M3	3,1	5,6	1,0	1,70	2,30
M3,5	3,6	6,1	1,0	1,70	2,30
M4	4,1	7,0	1,2	2,04	2,76
M5	5,1	8,6	1,5	2,55	3,45
M6	6,1	9,7	1,5	2,55	3,45
M8	8,2	12,8	2,0	3,40	4,60
M10	10,2	16,1	2,5	4,25	5,75
M12	12,2	18,3	2,5	4,25	5,75
M14	14,2	21,4	3,0	5,10	6,90
M16	16,2	24,6	3,5	5,95	8,05
M18	18,2	26,6	3,5	5,95	8,05
M20	20,2	30,6	4,5	7,65	10,35
M22	22,5	32,9	4,5	7,65	10,35
M24	24,5	35,9	5,0	8,50	11,50
M27	27,5	38,9	5,0	8,50	11,50
M30	30,5	44,2	6,0	10,20	13,80
M33	33,5	47,2	6,0	10,20	13,80
M36	36,5	52,3	7,0	11,90	16,10
M42	42,5	60,3	8,0	13,60	18,40

Dimensioni in mm  
Dimensions in mm

## DIMENSIONI O-RING SAE



## SAE O-RING DIMENSIONS

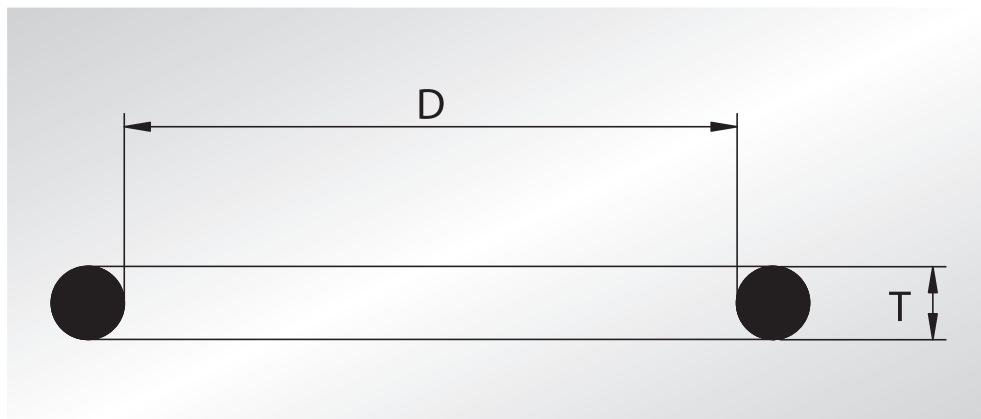

TIPO O-RING O-RING TYPE	D	T
121	15,88	1,78
132	23,81	2,62
144	39,69	3,53
150	46,04	3,53
156	52,39	3,53
2056	14,00	1,78
2075	18,77	1,78
2100	25,12	1,78
3068	17,13	2,62
3075	18,72	2,62
3100	25,07	2,62
3125	31,42	2,62
4075	18,64	3,53
4100	24,99	3,53
4112	28,17	3,53

TIPO O-RING O-RING TYPE	D	T
4131	32,93	3,53
4150	37,69	3,53
4187	47,22	3,53
4225	56,74	3,53
4237	59,92	3,53
4275	69,44	3,53
4337	85,32	3,53
4387	98,02	3,53
4437	110,7	3,53
4537	136,1	3,53
6225	56,52	5,34
6275	69,22	5,34
6300	75,57	5,34
6350	88,27	5,34
6387	97,79	5,34

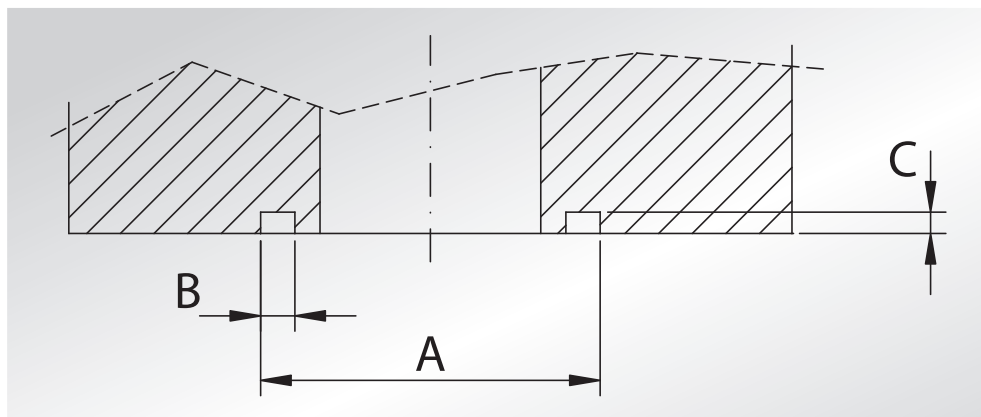

## DIMENSIONI SEDE O-RING SAE



## SAE O-RING SEAT DIMENSIONS

TIPO O-RING O-RING TYPE	A	B	C
121	21	3,5	2,15
132	29	3,5	2,15
144	46	4,5	2,8
150	53	4,5	2,8
156	60	4,5	2,8
2056	18	2,5	1,3
2075	22	2,5	1,3
2100	28	2,5	1,3
3068	22	3,5	2,15
3075	24	3,5	2,15
3100	30	3,5	2,15
3125	37	3,5	2,15
4075	25,5	4,5	2,8
4100	31,9	4,5	2,8
4112	39,7	4,5	2,8

TIPO O-RING O-RING TYPE	A	B	C
4131	39,7	4,5	2,8
4150	44,6	4,5	2,8
4187	54	4,5	2,8
4225	63,5	4,5	2,8
4237	67	4,5	2,8
4275	76,3	4,5	2,8
4337	92,1	4,5	2,8
4387	104,5	4,5	2,8
4437	117	4,5	2,8
4537	143	4,5	2,8
6225	68	7	4,5
6275	80	7	4,5
6300	86	7	4,5
6350	98	7	4,5
6387	108	7	4,5



**TABELLA SPESSORI SCHEDULE TUBI  
PER CORRISPONDENZA  
CON QUOTA "B" FLANGE SAE A SALDARE**

**TABLE FOR PIPES' THICKNESS  
FOR CROSS REFERENCE  
WITH "B" DIMENSION OF WELDING SAE FLANGES**

RIF. O.T. 3000	RIF. O.T. 6000	CARATTERISTICHE TUBO PIPE'S CHARACTERISTICS			SPESSORE THICKNESS				FLANGE "ST" STANDARD TUBO GAS	ANNOTAZIONI
		GRANDEZZA SIZE	DIAM. NOMINALE NOMINAL DIAM.	DIAM. EST. TUBO PIPE OUTSIDE DIAM.	SCH. 40	SCH. 80	SCH. 160	SCH. XXS	BSP PIPE STANDARD "ST" FLANGES	NOTES
080038	401038	3/8"	10	17,15	2,31	3,2	—	—	2,25	
080	401012	1/2"	15	21,34	2,77	3,73	4,78	7,47	4,25	
100	402	3/4"	20	26,67	2,87	3,91	5,56	7,82	4,5	
102	403	1"	25	33,4	3,38	4,55	6,35	9,09	4,5	
104	404	1"1/4	32	42,16	3,56	4,85	6,35	9,7	5,4	
106	405	1"1/2	40	48,26	3,68	5,08	7,14	10,16	5,3	
108	406	2"	50	60,3	3,91	5,54	8,74	11,07	5	
110	507	2"1/2	65	73,03	5,15	7,01	9,52	14,02	7	
112	508	3"	80	88,9	5,49	7,62	11,13	15,24	9,5	
114	—	3"1/2	90	101,6	5,74	8,08	—	—	7	
116	—	4"	100	114,3	6,02	8,56	13,49	17,12	8,25	
118	—	5"	125	141,3	6,55	9,52	15,88	19,05	10,1	

**NOTE**



**NOTES**

A large area of the page is filled with horizontal grey lines, serving as a template for writing notes.



**NOTE**

**NOTES**

A series of horizontal grey lines providing a space for writing notes.

**NOTE**



**NOTES**

A series of 25 horizontal grey lines providing a space for writing notes.



# oleo tecnica



APPARECCHIATURA DI MISURA TRIDIMENSIONALE A C.N. (SALA METROLOGICA)



FLANGIA JIC



FLANGIA FILETTATA METRICA  
ATTACCO DIN



SEMIFLANGIA CON CODOLO



RACCORDO 90° A 3 FORI



FLANGIA FILETTATA GAS



CONTROFLANGIA PIATTA  
A SALDARE DI TASCA



ACCOPPIAMENTO SEMIFLANGIA INTERA  
FORI FILETTATI CON CODOLO A  
SALDARE DI TESTA E FLANGIA  
FILETTATA GAS



ACCOPPIAMENTO SEMIFLANGIA INTERA  
FORI FILETTATI CON CODOLO A  
SALDARE DI TESTA E FLANGIA A 90°  
A SALDARE DI TESTA